

Tarif 2009/2010

50Hz



Validité de prix jusqu'à 2010/April/30

Groupes électrogènes 50Hz

Motosoudeuses

Groupes tracteur



ABAGEN

Abamotor Energía S.L.

GROUPES PROFESSIONNELS - 3000tr/mn - 8h/jour - 800h/an



GRUPOS PROFESIONALES - 3000tr/mn - 8h/jour - 800h/an



INSONORISÉS = MONOPHASÉS à 3000 TR/MN			
G5	TARIF GRUPOS ELECTROGENOS 50HZ 400V & 230V		3000 RPM
F	PROFESSIONNELS 3000rpm 8h/jour --- 800h/an	I	SOUNDPROOF
M/R/L	MOTEUR	A/O/W	SYSTEME DE REFRIGERISSEMENT
	M Minsel R Lombardini L Lister-Petter	A Air W Eau O Huile	
RC	Manuel - À distance	A	Automatique AMF panel

KVA	Données techniques	FIMA M6	FIRA M9	FILW M13	KVA
TECHNIQUES	Norme émissions 2002/88	Exempt	Exempt	Exempt	TECHNIQUES
	Secours / Continue [kVA]	5,5 / 5	9 / 8	13 / 11	
	Voltage [V] / Intensité [A] / Cos φ	230 / 24 / 0,9	230 / 37 / 0,9	230 / 56 / 0,9	
	Dim longueur x largeur x hauteur [mm]	1200/560/830	1200/560/830	1800/740/1170	
	Dim emballage long x larg x hauteur [mm]	1300/740/990	1300/740/990	1800/750/1230	
	Puissance acoustique LWA [dBA]	94	94	96	
MOTEUR	Pression acoustique LPA [dBA] 16m/10m/7m/4m	62/66/69/74	62/66/69/74	64/68/71/76	
	Réservoir [l] / Autonomie 75% (PRP) [h]	40 / 28	40 / 18	50 / 16	
	Unités par container 20' / 40'	24 / 56	24 / 56	9 / 19	
	Code moteur	1430-3376	2060	12537	
	Modèle	M430 FIMA	25LD330	LPW2	
	Fabricant	MINSEL	LOMBARDINI	LISTER	
RC	Couplage	Cone Ø23mm	Cone Ø30mm	SAE5 7½	
	Refrigerissement / N°cylindres /Aspiration	Air/1/Naturelle	Air/2/Naturelle	Eau/2/Naturelle	
	Coffret Manuel - RC	G5 FIMA M6 RC	G5 FIRA M9 RC	G5 FILW M13C1 RC	
	Code groupe électrogène	3383	2247	2797	
	Prix public	3.831 €	5.028 €	7.013 €	
	Poids net / Poids avec emballage [kg]	208 / 233	205 / 225	578 / 586	
ALT	Code Alternateur	14793	ALT-0076	13957	
	Modèle	SE100 FX	M100 LL	TR112 MC	
	Fabricant	SACCARDO	SACCARDO	SACCARDO	
	Système de régulation	CONDENS	CONDENS	AVR	
	Protection IP alternateur	IP21	IP21	IP23	
	RC	Type coffret	Manuel-Distance	Manuel-Distance	Manuel-Distance
Carté électronique		GPMR72	GPMR72	GPMR72	
Coffret de contrôle / Cableage de contrôle		3297/3125	2242/2945	14988/129	
Coffret de force / Cableage de force		3297/...187-116	2242/...187-116	2545/890	
A		Coffret automatique AMF - A	G5 FIMA M6 A	G5 FIRA M9 A	G5 FILW M13C1 A
		Code groupe électrogène	3384	2249	2558
	Prix public	4.114 €	5.347 €	7.000 €	
	Poids net / Poids avec emballage [kg]	215 / 239,8	230,7 / 251	577,6 / 586,2	
	ALT	Code Alternateur	1637	1638	13957
		Modèle	MR100 SF	MR100 LL	TR112 MC
Fabricant		SACCARDO	SACCARDO	SACCARDO	
Système de régulation		AVR	AVR	AVR	
Protection IP alternateur		IP23	IP23	IP23	
AUTO		Type coffret	Automatique AMF	Automatique AMF	Automatique AMF
	Carté électronique	GECO + V	GECO + V	GECO + V	
	Coffret de contrôle / Cableage de contrôle	3308/225	2245/225	1689/129	
	Coffret de force / Cableage de force	3308/...187-117	2245/...187-117	2581/890	
	KITS	Kit maint 1000 h MOTEUR	1430-1150 / 54€	.336-1051 / 90€	2x14589 / 108€
		Kit maint/secours 1000 h MOTEUR	1430-1152 / 82€	.336-1020 / 146€	2280 / 134€
Kit maint/secours 1000 h ALTERNATEUR (SE100)		1884 / 31€	-	-	
Kit maint/secours 1000 h ALTERNATEUR (M100)		Consulter	Consulter	Consulter	
Option		Option disponibles (Code / Prix public)			
		ALT	AVR: NSM AVR (For "RC" models)	2156 / 151€	2141 / 195€
		LSA: Leroy Somer alternateur	N.D.	N.D.	N.D.
	INS/ATS	1ATS: Separé ATS pour RC models	15925 / 170€	15925 / 170€	15925 / 170€
		2ATS: Intégré ATS pour RC models	15184 / 104€	15184 / 104€	N.D.
		2ATS: Separé ATS pour A models	15928 / 212€	15928 / 212€	15928 / 212€
Coffret		TEMP: Automatic start/stop clock for RC	3017 / 131€	3017 / 131€	3017 / 131€
		GPM2: GM2 controller (A+V/A+F/V+F)	N.D.	N.D.	N.D.
		GPM3: GPM3 digital controller for RC models	N.D.	N.D.	14231 / 230€
	GECO-MD: GECOMD digital for A models	N.D.	N.D.	14240 / 292€	
	AMF25: AMF25 digital for A with EMR	N.D.	N.D.	14184 / 453€	
	PROTDIF: Differential protection for A models	15382 / 16€	15382 / 16€	15384 / 118€	
Moteur	BASES: Shokets for RC models	SERIE	SERIE	15147 / 114€	
	DESCBAT: Battery disconnecter	N.D.	N.D.	15345 / 88€	
	VDO: Press & Pressure transmitt. (GPM3/AMF25)	N.D.	N.D.	15965 / 88€	
	EMR: Engine electronic governor	N.D.	N.D.	N.D.	
	AIRCALD: Air pre-heating for RC models	N.D.	N.D.	13095 / 80€	
	AIRCALD: Air pre-heating for A models	N.D.	N.D.	11777 / 165€	
Inst	OILCALD: Oil pre-heating	3139 / 261€	18756 / 281€	N.D.	
	LIQCALD: Liquid pre-heating	N.D.	N.A.	13086 / 467€	
	RESID: Residential muffler	SERIE	SERIE	SERIE	
	2,5FLEX50: 2,5m flexible tube for silencer	...934-032/ 55€	...934-032/ 55€	...934-032/ 55€	
	5FLEX50: 5m flexible tube for silencer	...934-033/ 93€	...934-033/ 93€	...934-033/ 93€	
	Chariot	C.OBRA: Not aproved trailer	N.D.	N.D.	1Axle / BALL 15518 / 920€
C.HOMOL: Aproved trailer (SPAIN)		N.D.	N.D.	1Axle / BALL 15519 / 1700€	
C.ART: Articulated rod		N.D.	N.D.	Consulter	
C.ARG: Ring type coupling		N.D.	N.D.	Consulter	
RUEDAS: On skid wheels manual transport		Consulter	Consulter	N.D.	
Comb.		DECCOMB: Fuel decanter	N.D.	N.D.	SERIE
	190L: Extra large 190L fuel tank	N.D.	N.D.	13493 / 273€	
	B-TR-MN: Semi-Automatic fuel electropump	N.D.	N.D.	N.D.	
	B-TR-AU: Automatic fuel electropump	N.D.	N.D.	N.D.	

3 ~



INSONORISÉS = TRIPHASÉS à 3000 TR/MN				
G5	TARIF GRUPEES ELECTROGENES 50HZ 400V & 230V			3000
F	PROFESSIONNELS 3000rpm 8h/jour --- 800h/an	I	SOUNDPROOF	
M/R/L	MOTEUR	A/O/W	SYSTÈME DE REFRIGÉRISSMENT	
	M R L	Minsel Lombardini Lister-Petter	A W O	Air Eau Huile
RC	Manuel - À distance		A	Automatique AMF panel

3000 RPM

50 HERTZ

KVA	Données techniques	FIMA T7	FIRA T10	FILW T15	FILW T22	KVA
TECHNIQUES	Norme émissions 2002/88	Exempt	Exempt	Exempt	No	DONNÉES TECHNIQUES
	Secours / Continue [kVA]	6,2 / 5,8	9,5 / 9	15 / 13	22 / 20	
	Voltage [V] / Intensité [A] / Cos φ	400 / 8,9 / 0,8	400 / 13,7 / 0,8	400 / 21,5 / 0,8	400 / 31,5 / 0,8	
	Dim longueur x largeur x hauteur [mm]	1200/560/830	1200/560/830	1800/740/1170	1800/740/1170	
	Dim emballage long x larg x hauteur [mm]	1300/740/990	1300/740/990	1800/750/1230	1800/750/1230	
	Puissance acoustique LWA [dBA]	94	94	96	97	
	Pression acoustique LPA [dBA] 16m/10m/7m/4m	62/66/69/74	62/66/69/74	64/68/71/76	65/69/72/77	
Réservoir [l] / Autonomie 75% (PRP) [h]	40 / 28	40 / 18	50 / 16	50 / 11		
Unités par container 20' / 40'	24 / 56	24 / 56	9 / 19	9 / 19		
MOTEUR	Code moteur	1430-3376	2060	12537	12533	MOTEUR
	Modèle	M430 FIMA	25LD330/0	LPW2/0	LPW3/0	
	Fabricant	MINSEL	LOMBARDINI	LISTER	LISTER	
	Couplage	Cone Ø23mm	Cone Ø30mm	SAE5 7½	SAE5 7½	
	Refrigérissement / N°cylindres /Aspiration	Air/1/Naturelle	Air/2/Naturelle	Eau/2/Naturelle	Eau/3/Naturelle	
RC	Coffret Manuel - RC	G5 FIMA T7 RC	G5 FIRA T10 RC	G5 FILW T15C1 RC	G5 FILW T22C1 RC	RC
	Code groupe électrogène	3511	2097	2097	2098	
	Prix public	4.077 €	5.210 €	6.800 €	7.498 €	
ALT	Code Alternateur	ALT-0012	13332	13947	13957	ALT
	Modèle	T100 SC	T100 LB	TR112 SC	TR112 MC	
	Fabricant	SACCARDO	SACCARDO	SACCARDO	SACCARDO	
	Système de régulation	COMPOUND	COMPOUND	AVR	AVR	
	Protection IP alternateur	IP23	IP23	IP23	IP23	
RC	Type coffret	Manuel-Distance	Manuel-Distance	Manuel-Distance	Manuel-Distance	RC
	Carté électronique	GPMR72	GPMR72	GPMR72 + V	GPMR72 + V	
	Coffret de contrôle / Cableage de contrôle	3294/3125	2243/1945	14988/129	14988/129	
	Coffret de force / Cableage de force	3294/...187-112	2243/...187-112	3245/1729	1760/1711	
A	Coffret automatique AMF - A	G5 FIMA T7 A	G5 FIRA T10 A	G5 FILW T15C1 A	G5 FILW T22C1 A	A
	Code groupe électrogène	3381	2248	2104	2105	
	Prix public	4.301 €	5.494 €	6.937 €	7.627 €	
ALT	Code Alternateur	1654	13866	13947	13957	ALT
	Modèle	TR100 SC	TR100 LB	TR112 SC	TR112 MC	
	Fabricant	SACCARDO	SACCARDO	SACCARDO	SACCARDO	
	Système de régulation	AVR	AVR	AVR	AVR	
	Protection IP alternateur	IP23	IP23	IP23	IP23	
AUTO	Type coffret	Automatique AMF	Automatique AMF	Automatique AMF	Automatique AMF	AUTO
	Carté électronique	GECO + V	GECO + V	GECO + V	GECO + V	
	Coffret de contrôle / Cableage de contrôle	3300/225	2244/225	16745/129	16745/129	
	Coffret de force / Cableage de force	3300/89	2244/89	1747/1729	1730/1711	
KITS	Kit maint 1000 h MOTEUR	1430-1150/54€	336-1051/90€	2x14589 / 108€	2x14591/114€	KITS
	Kit maint/emerg 1000 h MOTEUR	1430-1152/82€	336-1020 / 146€	2280 / 134€	2281/141€	
	Kit maint/secsours 1000 h ALTERNATEUR (NSM)	1882 / 27€	1882 / 27€	Consulter	Consulter	
Options	Options disponibles (Code / Prix public)					Options
ALT	AVR: NSM AVR (For "RC" models)	2167 / 162€	1000-5205 / 123€	SERIE	SERIE	ALT
	LSA: Leroy Somer alternator	N.D.	N.D.	N.D.	N.D.	
INS/ATS	1ATS: Separated ATS for RC models	1976 / 170€	1976 / 170€	1976 / 170€	1976 / 170€	INS/ATS
	2ATS: Integrated ATS for RC models	15185 / 95€	15185 / 95€	N.D.	N.D.	
	2ATS: Separated ATS for A models	1977 / 212€	1977 / 212€	1977 / 212€	1977 / 212€	
	TEMP: Automatic start/stop clock for RC	3017 / 131€	3017 / 131€	3017 / 131€	3017 / 131€	
Panel	220V: 220V output for RC models	15389 / ASK	15389 / ASK	15393 / 58€	N.D.	Panel
	220V: 220V output for A models	15390 / ASK	15390 / ASK	15394 / 42€	N.D.	
	GPM2: GM2 controller (A+V/A+F/V+F)	N.D.	N.D.	15142 / 138€	15142 / 138€	
	GPM3: GPM3 digital controller for RC models	N.D.	N.D.	14231 / 230€	14231 / 230€	
	GECO-MD: GECOMD digital for A models	N.D.	N.D.	14240 / 292€	14240 / 292€	
	AMF25: AMF25 digital for A with EMR	N.D.	N.D.	14184 / 453€	14184 / 453€	
	PROTDIF: Differential protection A models	15385 / 84€	15385 / 84€	15387 / 73€	15388 / 80€	
	BASES: Shokets for RC models	SERIE	SERIE	15145 / 118€	15145 / 118€	
	DESCBAT: Battery disconnecter	N.D.	N.D.	15345 / 85€	15345 / 85€	
	VDO: Press & Pressure transmitt. (GPM3/AMF25)	N.D.	N.D.	15965 / 88€	15965 / 88€	
Engine	EMR: Engine electronic governor	N.D.	N.D.	N.D.	N.D.	Engine
	AIRCALD: Air pre-heating for RC models	N.D.	N.D.	13095 / 80€	13095 / 80€	
	AIRCALD: Air pre-heating for A models	N.D.	N.D.	11777 / 165€	11777 / 165€	
	OILCALD: Oil pre-heating	3139 / 261€	18756 / 281€	N.D.	N.D.	
	LIQCALD: Liquid pre-heating	N.D.	N.D.	13086 / 482€	13086 / 482€	
Inst	RESID: Residential muffler	SERIE	SERIE	SERIE	SERIE	Inst
	2,5FLEX50: 2,5m flexible tube for silencer	...934-032/55€	...934-032/55€	...934-032/55€	...934-032/55€	
	5FLEX50: 5m flexible tube for silencer	...934-033/93€	...934-033/93€	...934-033/93€	...934-033/93€	
Trailer	C.OBRA: Not aproved trailer	N.D.	N.D.	1EJE / BOLA 15518 / 920€	1EJE / BOLA 15518 / 920€	Trailer
	C.HOMOL: Aproved trailer (SPAIN)	N.D.	N.D.	1EJE / BOLA 15519 / 1700€	1EJE / BOLA 15519 / 1700€	
	C.ART: Articulated rod	N.D.	N.D.	Consulter	Consulter	
	C.ARG: Ring type coupling	N.D.	N.D.	Consulter	Consulter	
	RUEDAS: On skid wheels manual transport	Consulter	Consulter	N.D.	N.D.	
Fuel	DECCOMB: Fuel decanter	N.D.	N.D.	SERIE	SERIE	Fuel
	190L: Extra large 190L fuel tank	N.D.	N.D.	13493 / 273€	13493 / 273€	
	B-TR-MN: Semi-Automatic fuel electropump	N.D.	N.D.	N.D.	N.D.	
B-TR-AU: Automatic fuel electropump	N.D.	N.D.	N.D.	N.D.		

1 ~



OUVERTS = MONOPHASÉS à 3000 TR/MN						
G5		TARIF GRUPOS ELECTROGENOS 50HZ 400V & 230V				
F		PROFESSIONNELS 3000rpm 8h/jour --- 800h/an		A		OUVERTS
M/R/L		MOTEUR		SYSTEME DE REFROIDISSEMENT		
		M	Minsel	A/O/W		A Air
		R	Lombardini			W Eau
		L	Lister-Petter			O Huile
RC		Manuel - à distance		A		Automatique AMF panel

3000 RPM

50 HERTZ

KVA	Données techniques	FAMA M6	FAMA M7	FAMA M8	FARA M9	FALW M13	KVA
TECHNIQUES	Norme émissions 2002/88	Exempt	Exempt	Exempt	Exempt	Exempt	TECHNIQUES
	Secours / Continue [kVA]	5,5 / 5	7 / 6,7	8 / 7	8,5 / 7,7	13 / 11	
	Voltage [V] / Intensité [A] / Cos φ	230 / 24 / 0,9	230 / 30 / 0,9	230 / 34 / 0,9	230 / 37 / 0,9	230 / 56 / 0,9	
	Dim longueur x largeur x hauteur [mm]	823/620/680	823/620/680	823 / 620 / 680	880 / 620 / 650	1450/750/1050	
	Dim emballage long x larg x hauteur [mm]	850/680/790	850/680/790	850 / 680 / 790	940 / 840 / 850	1500/800/1230	
	Puissance acoustique LWA [dBA]	109	110	112	103	104	
	Pression acoustique LPA [dBA] 16m/10m/7m/4m	77/81/84/89	78/82/85/90	80/84/87/92	71/75/78/83	72/76/79/84	
Réservoir [l] / Autonomie 75% (PRP) [h]	18 / 12,5	18 / 9	18 / 7,8	18 / 8	30 / 10		
Unités par container 20' / 40'	44 / 96	44 / 96	44 / 96	28 / 56	10 / 21		
MOTEUR	Code moteur	1430-5015	.224-4758	.226-4758	.336-0022	2085	MOTEUR
	Modèle	M430	M540	M600	25LD330/O	LPW2/O	
	Fabricant	MINSEL	MINSEL	MINSEL	LOMBARDINI	LISTER	
	Couplage	Cone Ø23mm	Cone Ø30mm	Cone Ø30mm	Cone Ø30mm	SAE5 7½	
	Refroidissement / N°cylindres /Aspiration	Air/1/Naturelle	Air/1/Naturelle	Air/1/Naturelle	Air/2/Naturelle	Water/2/Naturelle	
RC	Coffret Manuel - RC	G5 FAMA M6 RC	G5 FAMA M7 RC	G5 FAMA M8 RC	G5 FARA M9 RC	G5 FALW M13 RC	RC
	Prix public	GED0109	GED0257	N.D.	GED0092	2701	Prix public
	Poids net / Poids avec emballage [kg]	134 / 144	141 / 151		144 / 160	400 / 415	
ALT	Code Alternateur	14793	ALT-0076		ALT-0076	13957	ALT
	Modèle	SE100FX	M100LL		M100LL	TR112 MC	
	Fabricant	SACCARDO	SACCARDO		SACCARDO	SACCARDO	
	Système de régulation	CONDENS	CONDENS		CONDENS	AVR	
Protection IP alternateur	IP21	IP23		IP23	IP23		
RC	Type coffret	Manual-Distance	Manual-Distance		Manual-Distance	Manual-Distance	RC
	Carté électronique	GPMR72 + V	GPMR72 + V		GPMR72 + V	GPMR72 + V	
	Coffret de contrôle / Cableage de contrôle	.224-1034/-	.224-1034/-		.224-1034/-	14988/129	
	Coffret de force / Cableage de force	.224-1034/-	.224-1034/-		.224-1034/-	2545/890	
A	Coffret automatique AMF - A	G5 FAMA M6 A	G5 FAMA M7 A	G5 FAMA M8 A	G5 FARA M9 A	G5 FALW M13 A	A
	Prix public	GED0154	GED0179	GED0209	GED0290	2791	Prix public
	Poids net / Poids avec emballage [kg]	135 / 145,1	142 / 152,1	160 / 170,1	143 / 158,7	400 / 415	
ALT	Code Alternateur	1637	1638	1638	1638	13957	ALT
	Modèle	MR100 SF	MR100 LL	MR100 LL	MR100 LL	TR112 MC	
	Fabricant	SACCARDO	SACCARDO	SACCARDO	SACCARDO	SACCARDO	
	Système de régulation	AVR	AVR	AVR	AVR	AVR	
Protection IP alternateur	IP23	IP23	IP23	IP23	IP23		
AUTO	Type coffret	Automatique-AMF	Automatique-AMF	Automatique-AMF	Automatique-AMF	Automatique-AMF	AUTO
	Carté électronique	GECO + V	GECO + V	GECO + V	GECO + V	GECO + V	
	Coffret de contrôle / Cableage de contrôle	...805-017/88	...805-017/88	...805-017/88	...805-017/88	1689/129	
	Coffret de force / Cableage de force	...805-017/...187-408	...805-017/...187-408	...805-017/...187-408	...805-017/...187-408	2581/890	
KITS	Kit mant 1000 ENGINE	1430-1150/54€	1430-1150/54€	1430-1150/54€	336-1051/90€	2276/108€	KITS
	Kit maint/secours 1000 horas MOTEUR	1430-1152/82€	1430-1152/82€	1430-1152/82€	336-1020/146€	2280/134€	
	Kit maint/secours 1000 h ALTERNATEUR (SE100)	1884 / 31€	-	-	-	-	
	Kit maint/secours 1000 h ALTERNATEUR (M100)	Consulter	Consulter	Consulter	Consulter	Consulter	
Option	Options disponibles (Code / Prix public)						Option
ALT	AVR: NSM AVR (For "RC" models)	2156 / 151€	2141 / 195€	NO RC	2141 / 195€	SERIE	ALT
	LSA: Leroy Somer alternator	N.D.	N.D.	N.D.	N.D.	N.D.	
INS/ATS	1ATS: Separated ATS for RC models	15925 / 170€	15925 / 170€	15925 / 170€	15925 / 170€	15925 / 170€	INS/ATS
	2ATS: Integrated ATS for RC models	15184 / 104€	15184 / 104€	15184 / 104€	15184 / 104€	N.D.	
	2ATS: Separated ATS for A models	15928 / 212€	15928 / 212€	15928 / 212€	15928 / 212€	15928 / 212€	
Coffret	TEMP: Automatic start/stop clock for RC	3017 / 131€	3017 / 131€	3017 / 131€	3017 / 131€	3017 / 131€	Coffret
	GPM2: GM2 controller (A+V/A+F/V+F)	N.D.	N.D.	N.D.	N.D.	N.D.	
	GPM3: GPM3 digital controller for RC models	N.D.	N.D.	N.D.	N.D.	14231 / 230€	
	GECO-MD: GECOMD digital for A models	N.D.	N.D.	N.D.	N.D.	14240 / 292€	
	AMF25: AMF25 digital for A with EMR	N.D.	N.D.	N.D.	N.D.	14184 / 453€	
	PROTDIF: Differential protection A models	15382 / 16€	15382 / 16€	15382 / 16€	15382 / 16€	15384 / 118€	
	BASES: Shokets for RC models	SERIE	SERIE	SERIE	SERIE	N.D.	
DESCBAT: Battery disconnecter	Consulter	Consulter	Consulter	Consulter	15345 / 88€		
Moteur	VDO: Press & Pressure transmitt. (GPM3/AMF25)	N.D.	N.D.	N.D.	N.D.	15965 / 88€	Moteur
	EMR: Engine electronic governor	N.D.	N.D.	N.D.	N.D.	N.D.	
	AIRCALD: Air pre-heating for RC models	N.D.	N.D.	N.D.	N.D.	13095 / 80€	
	AIRCALD: Air pre-heating for A models	N.D.	N.D.	N.D.	N.D.	11777 / 165€	
	OILCALD: Oil pre-heating	3139 / 261€	3139 / 261€	3139 / 261€	3139 / 261€	N.D.	
LIQCALD: Liquid pre-heating	N.D.	N.D.	N.A.	N.A.	13086 / 482€		
Inst	RESID: Residential muffler	N.D.	N.D.	N.A.	N.A.	15284 / 198€	Inst
	2_5FLEX50: 2,5m flexible tube for silencer	...934-032/55€	...934-032/55€	...934-032/55€	...934-032/55€	...934-032/55€	
	5FLEX50: 5m flexible tube for silencer	...934-033/93€	...934-033/93€	...934-033/93€	...934-033/93€	...934-033/93€	
Chariot	C.OBRA: Not approved trailer	1430-1132/72€	1430-1132/72€	1430-1132/72€	336-1037/89€	N.D.	Chariot
	C.HOMOL: Aproved trailer (SPAIN)	N.D.	N.D.	N.D.	N.D.	1 Axle / Ball 3138 / 869€	
	C.ART: Articulated rod	N.D.	N.D.	N.D.	N.D.	Consulter	
	C.ARG: Ring type coupling	N.D.	N.D.	N.D.	N.D.	15335 / 40€	
Comb	DECCOMB: Fuel decanter	N.D.	N.D.	N.D.	N.D.	SERIE	Comb
	190L: Extra large 190L fuel tank	N.D.	N.D.	N.D.	N.D.	18082 / 391€	
	B-TR-MN: Semi-Automatic fuel electropump	N.D.	N.D.	N.D.	N.D.	Consulter	
B-TR-AU: Automatic fuel electropump	N.D.	N.D.	N.D.	N.D.	Consulter		

3 ~



OUVERTS = TRIPHASÉS à 3000 TR/MN							
G5				TARIF GRUPOS ELECTROGENOS 50HZ 400V & 230V			
F				A			
PROFESSIONNELS 3000rpm 8h/jour --- 800h/an				OUVERTS			
M/R/L				A/O/W			
M	R	L		A	O	W	
Minsel Lombardini Lister-Petter				SYSTEME DE REFROIDISSEMENT			Air Eau Huile
RC				A			
Manuel - à distance				Automatique AMF panel			

3000 RPM

50 HERTZ

KVA	Données techniques	FAMA T7	FAMA T8	FAMA T9	FARA T10	FALW T15	FALW T22	KVA
TECHNIQUES	Norme émissions 2002/88	Exempt	Exempt	Exempt	Exempt	Exempt	No	TECHNIQUES
	Secours / Continue [kVA]	6,2 / 5,8	8 / 7,5	9 / 8	9,5 / 9	15 / 13	22 / 20	
	Voltage [V] / Intensité [A] / Cos φ	400 / 8,9 / 0,8	400 / 11,5 / 0,8	400 / 13 / 0,8	400 / 13,7 / 0,8	400 / 21,5 / 0,8	400 / 31,5 / 0,8	
	Dim longueur x largeur x hauteur [mm]	823/620/680	823/620/680	823 / 620 / 680	880 / 620 / 650	1450/750/1050	1450/750/1050	
	Dim emballage long x larg x hauteur [mm]	850/680/790	850/680/790	850 / 680 / 790	940 / 840 / 850	1500/800/1230	1500/800/1230	
	Puissance acoustique LWA [dBA]	109	110	112	103	104	103	
	Pression acoustique LPA [dBA] 16m/10m/7m/4m	77/81/84/89	78/82/85/90	80/84/87/92	71/75/78/83	72/76/79/84	71/75/78/83	
	Réservoir [l] / Autonomie 75% (PRP) [h]	18 / 12,5	18 / 9	18 / 7,8	18 / 8	30 / 10	30 / 7	
Unités par container 20' / 40'	44 / 96	44 / 96	44 / 96	28 / 56	10 / 21	10 / 21		
MOTEUR	Code moteur	1430-5015	224-4758	226-4758	336-0022	2085	2087	MOTEUR
	Modèle	M430	M540	M600	25LD330/O	LPW2/O	LPW3/O	
	Fabricant	MINSEL	MINSEL	MINSEL	LOMBARDINI	LISTER	LISTER	
	Couplage	Cono Ø23mm	Cono Ø30mm	Cono Ø30mm	Cono Ø30mm	SAE5 7/8"	SAE5 7/8"	
	Refroidissement / N°cylindres /Aspiration	Air/1/Naturelle	Air/1/Naturelle	Air/1/Naturelle	Air/2/Naturelle	Eau/2/Naturelle	Eau/3/Naturelle	
RC	Coffret Manuel - RC	G5 FAMA T7 RC	G5 FAMA T8 RC	G5 FAMA T9 RC	G5 FARA T10 RC	G5 FALW T15 RC	G5 FALW T22 RC	RC
	Prix public	GEDO256	GEDO258	Non disponible	GEDO105	3020	2092	
	Poids net / Poids avec emballage [kg]	2.534 €	2.803 €		3.612 €	5.041 €	5.687 €	
ALT	Code Alternateur	ALT-0012	13332		13332	13947	13957	ALT
	Modèle	T100SC	T100 LB		T100 LB	TR112 SC	TR112 MC	
	Fabricant	SACCARDO	SACCARDO		SACCARDO	SACCARDO	SACCARDO	
	Système de régulation	COMPOUND	COMPOUND		COMPOUND	AVR	AVR	
	Protection IP alternateur	IP23	IP23		IP23	IP23	IP23	
RC	Type coffret	Manual-Distance	Manual-Distance		Manual-Distance	Manual-Distance	Manual-Distance	RC
	Carté électronique	GPMR72 + V	GPMR72 + V		GPMR72 + V	GPMR72 + V	GPMR72 + V	
	Coffret de contrôle / Cableage de contrôle	.336-1023/-	.336-1023/-		.336-1023/-	14988/129	14988/129	
	Coffret de force / Cableage de force	.336-1023/-	.336-1023/-		.336-1023/-	3245/1729	1760/1711	
A	Coffret automatique AMF - A	G5 FAMA T7 A	G5 FAMA T8 A	G5 FAMA T9 A	G5 FARA T10 A	G5 FALW T15 A	G5 FALW T22 A	A
	Prix public	GEDO042	GEDO022	GEDO168	GEDO028	3253	2140	
	Poids net / Poids avec emballage [kg]	2.994 €	3.225 €	3.302 €	4.038 €	5.127 €	5.816 €	
ALT	Code Alternateur	1654	13866	13866	13866	13947	13957	ALT
	Modèle	TR100SC	TR100LB	TR100LB	TR100LB	TR112 SC	TR112 MC	
	Fabricant	SACCARDO	SACCARDO	SACCARDO	SACCARDO	SACCARDO	SACCARDO	
	Système de régulation	AVR	AVR	AVR	AVR	AVR	AVR	
	Protection IP alternateur	IP23	IP23	IP23	IP23	IP23	IP23	
AUTO	Type coffret	Automatique AMF	Automatique AMF	Automatique AMF	Automatique AMF	Automatique AMF	Automatique AMF	AUTO
	Carté électronique	GECO + V	GECO + V	GECO + V	GECO + V	GECO + V	GECO + V	
	Coffret de contrôle / Cableage de contrôle	...805-024/88	...805-024/88	...805-024/88	...805-024/88	16745/129	16745/129	
	Coffret de force / Cableage de force	...805-024/89	...805-024/89	...805-024/89	...805-024/89	1747/1729	1730/1711	
KITS	Kit mant 1000H MOTEUR	1430-1150 / 54€	1430-1150 / 54€	1430-1150 / 54€	.336-1051 / 90€	2276 / 108€	22278 / 116€	KITS
	Kit mant/secours 1000h MOTEUR	1430-1152 / 82€	1430-1152 / 82€	1430-1152 / 82€	.336-1020 / 146€	2280 / 134€	2281 / 141€	
	Kit mant/secours 1000 h ALTERNATEUR (SACCARDO)	1882 / 27€	1882 / 27€	1882 / 27€	1882 / 27€	Consulter	Consulter	
Options	Options disponibles (Code/Prix public)							Options
ALT	AVR: NSM AVR (For "RC" models)	2167 / 162€	1000-5205/123€	NO RC model	1000-5205/123€	SERIE	SERIE	ALT
	LSA: Leroy Somer alternator	N.D.	N.D.	N.D.	N.D.	N.D.	N.D.	
INS/ATS	1ATS: Separated ATS for RC models	1976 / 170€	1976 / 170€	1976 / 170€	1976 / 170€	1976 / 170€	1976 / 170€	INS/ATS
	2ATS: Integrated ATS for RC models	15185 / 95€	15185 / 95€	15185 / 95€	15185 / 95€	N.D.	N.D.	
	2ATS: Separated ATS for A models	1977 / 212€	1977 / 212€	1977 / 212€	1977 / 212€	1977 / 212€	1977 / 212€	
Coffret	220V: Output 220V for RC models	15389 / 50€	15389 / 50€	15389 / 50€	15389 / 50€	15393 / 58€	N.D.	Coffret
	220V: Output 220V for A models	15390 / ASK	15390 / ASK	15390 / ASK	15390 / ASK	15394 / 42€	N.D.	
	TEMP: Automatic start/stop clock for RC	3017 / 131€	3017 / 131€	3017 / 131€	3017 / 131€	3017 / 131€	3017 / 131€	
	GPM2: GPM2 controller (A+V/A+F/V+F)	N.D.	N.D.	N.D.	N.D.	N.D.	N.D.	
	GPM3: GPM3 digital controller for RC models	N.D.	N.D.	N.D.	N.D.	14231 / 230€	14231 / 230€	
	GECO-MD: GECOMD digital for A models	N.D.	N.D.	N.D.	N.D.	14240 / 292€	14240 / 292€	
	AMF25: AMF25 digital for A with EMR	N.D.	N.D.	N.D.	N.D.	14184 / 453€	14184 / 453€	
	PROTDIF: Differential protection A models	15385 / 84€	15385 / 84€	15385 / 84€	15385 / 84€	15387 / 73€	15388 / 80€	
	BASES: Shokets for RC models	SERIE	SERIE	SERIE	SERIE	N.D.	N.D.	
	DESCBAT: Battery disconnect	Consulter	Consulter	Consulter	Consulter	15345 / 88€	15345 / 88€	
Moteur	VDO: Press & Pressure transmitt. (GPM3/AMF25)	N.D.	N.D.	N.D.	N.D.	15965 / 88€	15965 / 88€	Moteur
	EMR: Engine electronic governor	N.D.	N.D.	N.D.	N.D.	N.D.	N.D.	
	AIRCALD: Air pre-heating for RC models	N.D.	N.D.	N.D.	N.D.	13095 / 80€	13095 / 80€	
	AIRCALD: Air pre-heating for A models	N.D.	N.D.	N.D.	N.D.	11777 / 165€	11777 / 165€	
	OILCALD: Oil pre-heating	3139 / 261€	3139 / 261€	3139 / 261€	3139 / 261€	N.D.	N.D.	
	LIQCALD: Liquid pre-heating	N.D.	N.D.	N.D.	N.D.	13086 / 482€	13086 / 482€	
Inst	RESID: Residential muffler	N.D.	N.D.	N.D.	N.D.	15284 / 198€	15284 / 198€	Inst.
	2,5FLEX50: 2,5m flexible tube for silencer	...934-032/55€	...934-032/55€	...934-032/55€	...934-032/55€	...934-032/55€	...934-032/55€	
	5FLEX50: 5m flexible tube for silencer	...934-033/93€	...934-033/93€	...934-033/93€	...934-033/93€	...934-033/93€	...934-033/93€	
Chariot	RUEDAS: On skid wheels for manual transport	1430-1132/72€	1430-1132/72€	1430-1132/72€	.336-1037/88€	N.D.	N.D.	Chariot
	C.OBRA: Not approved trailer option	N.D.	N.D.	N.D.	N.D.	1 Axle / Ball	1 Axle / Ball	
	C.ART: Articulated rod	N.D.	N.D.	N.D.	N.D.	3138 / 869€	3138 / 869€	
Comb	C.ARG: Ring type coupling	N.D.	N.D.	N.D.	N.D.	Consulter	Consulter	Comb
	DECCOMB: Fuel decanter	N.D.	N.D.	N.D.	N.D.	15335 / 40€	15335 / 40€	
	190L: Extra large 190L fuel tank	N.D.	N.D.	N.D.	N.D.	18082 / 391€	18082 / 391€	
	B-TR-MN: Semi-Automatic fuel electropump	N.D.	N.D.	N.D.	N.D.	15432 / 500€	15432 / 500€	
B-TR-AU: Automatic fuel electropump	N.D.	N.D.	N.D.	N.D.	15433 / 542€	15433 / 542€		

Groupes ouverts 1500tr/mn - 24h/jour - 2000h/an



Groupes ouverts 1500tr/mn - 24h/jour - 2000h/an



GROUPES OUVERTS = MONOPHASES à 1500tr/mn						
TARIF GROUPES ELECTROGENES 50HZ						
G5	CONTINU			OUVERT		
C	1500rpm 24h/jour --- 2000h/an			MOTEUR		
R/L/D	D R L	Deutz Lombardini Lister-Petter	A/W	Système de refroidissement A Air W Eau		
RC	Manuel - à distance			A	Automatique AMF panel	

50
HERTZ

1500
RPM

KVA	Données techniques	CADA M13	CADA M21	CALW M31	CADA M31	CADA M42	KVA		
TECHNIQUES	Norme d'émissions 2002/88	OUI	OUI	NON	OUI	OUI	TECHNIQUES		
	Secours / Continu [kVA]	13 / 11	20,6 / 18,5	30,6 / 28	30,6 / 28	42 / 38			
	Voltage [V] / Intensité [A] / Cos φ	230 / 56 / 0,9	230 / 90 / 0,9	230 / 133 / 0,9	230 / 133 / 0,9	230 / 182 / 0,9			
	Dimensions longueur x largeur x hauteur [mm]	1450/750/1010	1450/750/1100	1630/850/1150	1630/850/1150	1630/850/1160			
	Dim emballage long x larg x hauteur [mm]	1500/800/1230	1500/800/1230	1700/940/1230	1700/940/1230	1700/940/1230			
	Puissance acoustique LWA [dBA]	99	100	CONSULTAR	103	97			
	Pression acoustique LPA [dBA] 16m/10m/7m/4m	67/71/74/79	68/72/75/80	CONSULTAR	71/75/78/83	65/69/72/77			
Réservoir [l] / Autonomie 75% (PRP) [h]	30 / 12	30 / 8	60 / 10	60 / 11	60 / 8				
Unités par container 20' / 40'	10 / 21	10 / 21	6 / 14	6 / 14	6 / 14				
MOTEUR	Code moteur	171	197	14961	199	201	MOTEUR		
	Modèle	F2L2011/8	F3L2011/8	DWS4-03/8	F4L2011/8	BF4L2011/8			
	Fabricant	DEUTZ	DEUTZ	LISTER	DEUTZ	DEUTZ			
	Couplage	SAE3 11½	SAE3 11½	SAE3 11½	SAE3 11½	SAE3 11½			
	Refroidissement / N° cylindres / Aspiration	Air/2/Naturelle	Air/3/Naturelle	Eau/4/Naturelle	Eau/4/Naturelle	Air/4/Turbo			
ALT	Code alternateur	18808	1151	1134	1134	642	ALT		
	Modèle	LSA 40 L7	LSA 42.2 L9	LSA43.2S15	LSA43.2S15	LSA43.2M45			
	Fabricant	LEROY SOMER	LEROY SOMER	LEROY SOMER	LEROY SOMER	LEROY SOMER			
	Système de regulation	AVR	AVR	AVR	AVR	AVR			
	Alternateur IP protection	IP23	IP23	IP23	IP23	IP23			
RC	Manuel / à distance - RC	G5 CADA M13 RC	G5 CADA M21 RC	G5 CALW M31 RC	G5 CADA M31 RC	G5 CADA M42 RC	RC		
	Code groupe électrogène	420	2736	15191	871	12473			
	Prix public	6.850 €	7.820 €	8.738 €	8.599 €	9.791 €			
Prix public	Poid net / Poids avec emballage [kg]	491 / 500	530 / 539	635 / 643	645 / 654	748 / 760	Prix public		
	RC	Coffret	Manuel-Distance	Manuel-Distance	Manuel-Distance	Manuel-Distance		Manuel-Distance	RC
		Carté électronique	GPMR72 + V	GPMR72 + V	GPMR72 + V	GPMR72 + V		GPMR72 + V	
Coffret de contrôle / Cableage de contrôle		14988/226	14988/226	14988/129	14988/226	14988/226			
A	Automatique AMF panel - A	G5 CADA M13 A	G5 CADA M21 A	G5 CALW M31 A	G5 CADA M31 A	G5 CADA M42 A	A		
	Code groupe électrogène	798	2739	15192	15053	3606			
	Prix public	6.830 €	7.776 €	8.698 €	8.560 €	9.747 €			
Prix public	Poid net / Poids avec emballage [kg]	490,9 / 499,6	529,9 / 538,6	635 / 643	644,9 / 653,6	748 / 760	Prix public		
	AUTO	Coffret	Automatique AMF	Automatique AMF	Automatique AMF	Automatique AMF		Automatique AMF	AUTO
		Carté électronique	GECO + V	GECO + V	GECO + V	GECO + V		GECO + V	
Coffret de contrôle / Cableage de contrôle		1689/226	1689/226	1689/129	1689/226	1689/226			
KITS	Kit mant 1000 h MOTEUR	DEU-1080/58€	DEU-1080/58€	657-76130/280€	DEU-1080/58€	DEU-1090/112€	KITS		
	Kit mant/secours 1000h MOTEUR	DEU-1093/77€	DEU-1093/77€	15527 / 358€	DEU-1093/77€	DEU-1109/136€			
	Kit mant/secours 1000h ALTERNATEUR (NSM)	-	-	-	-	-			
Options	Options disponibles (Code / Prix public)						Options		
	AVR: NSM AVR alternator	SERIE	SERIE	SERIE	SERIE	SERIE			
	LSA: Leroy Somer alternator	SERIE	SERIE	SERIE	SERIE	SERIE			
	LSA-TR: Leroy Somer tropicalized	XXXX / 271€	14175 / 271€	14176 / 271€	14176 / 271€	12419 / 265€			
	LSA-PMG: Leroy Somer PMG system	Consulter	Consulter	Consulter	Consulter	Consulter			
INS/ATS	LSACALD: Leroy Somer with preheating	XXXX / 203€	14251 / 162€	15153 / 215€	15153 / 215€	15489 / 215€	INS/ATS		
	1ATS: Integrated ATS for RC models	N.D.	N.D.	N.D.	N.D.	N.D.			
	1ATS: Separated ATS for RC models	15926 / 294€	15926 / 294€	15926 / 294€	15926 / 294€	15927 / 477€			
Coffret	2ATS: Separated ATS for A models	15929 / 479€	15929 / 479€	15929 / 479€	15929 / 479€	15930 / 920€	Coffret		
	TEMP: Automatic start/stop clock for RC	3017 / 131€	3017 / 131€	3017 / 131€	3017 / 131€	3017 / 131€			
	GPM2: GM2 controller (A+V/A+F/V+F)	N.D.	N.D.	N.D.	N.D.	N.D.			
	GPM3: GPM3 digital controller for RC models	14231 / 230€	14231 / 230€	14231 / 230€	14231 / 230€	14231 / 230€			
	GECO-MD: GECOMD digital for A models	14240 / 292€	14240 / 292€	14240 / 292€	14240 / 292€	14240 / 292€			
	AMF25: AMF25 digital for A with EMR	15023 / 161€	14184 / 453€	14184 / 453€	14184 / 453€	14184 / 453€			
	PROTDIF: Differential protection A models	15407 / 118€	15409 / 154€	15434 / 149€	15434 / 149€	15435 / 187€			
	BASES: Shokets for RC models	N.D.	N.D.	N.D.	N.D.	N.D.			
	DESCBAT: Battery disconnecter	15345 / 88€	15345 / 88€	15345 / 88€	15345 / 88€	15345 / 88€			
	VDO: Press & Temp transmitt. (GPM3/AMF25)	15967 / 130€	15967 / 130€	15967 / 130€	15967 / 130€	15967 / 130€			
Moteur	EMR-A: Engine electronic governor for A	15276 / 1102€	15277 / 1102€	N.D.	15288 / 1102€	15288 / 1102€	Moteur		
	EMR-RC: Engine electronic governor for RC	15269 / 810€	15271 / 810€	N.D.	15022 / 810€	15022 / 810€			
	EMR-BUS: Engine MODBUS (needs AMF25)	15349 / 325€	15349 / 325€	15349 / 325€	15349 / 325€	15349 / 325€			
	AIRCALD: Air pre-heating for RC models	13098 / 155€	13098 / 155€	13098 / 155€	13098 / 155€	13098 / 155€			
	AIRCALD: Air pre-heating for A models	13041 / 243€	13041 / 243€	13041 / 243€	13041 / 243€	13041 / 243€			
	OILCALD: Oil pre-heating	N.D.	N.D.	N.D.	N.D.	N.D.			
	LIQCALD: Liquid pre-heating	N.D.	N.D.	N.D.	N.D.	N.D.			
Inst	RESID: Residential muffler	3465 / 198€	3465 / 198€	15284 / 198€	3465 / 198€	3465 / 198€	Inst		
	2_5FLEX50: 2,5m flexible tube for silencer	...934-032 / 55€	...934-032 / 55€	...934-032/55€	...934-032/55€	...934-032/55€			
	5FLEX50: 5m flexible tube for silencer	...934-033 / 93€	...934-033 / 93€	...934-033/93€	...934-033/93€	...934-033/93€			
Chariot	C.OBRA: Not approved trailer	3138 / 947€	3138 / 947€	3488 / 1.062€	3488 / 1.062€	3488 / 1.062€	Chariot		
	C.ART: Articulated rod	Consulter	Consulter	Consulter	Consulter	Consulter			
	C.ARG: Ring type coupling	15335 / 42€	15335 / 42€	15335 / 40€	15335 / 40€	15335 / 40€			
Comb	DECCOMB: Fuel decanter	18083 / 391€	18083 / 391€	SERIE	15970 / 350€	15970 / 350€	Comb		
	190L: Extra large 190L fuel tank	15970 / 361€	15970 / 361€	N.D.	17162 / 391€	17162 / 391€			
	B-TR-MN: Semi-Automatic fuel electropump	15432 / 500€	15432 / 500€	15432 / 500€	15432 / 500€	15432 / 500€			
B-TR-AU: Automatic fuel electropump	15433 / 542€	15433 / 542€	15433 / 542€	15433 / 542€	15433 / 542€				



GROUPES OUVERTS = TRIPHASÉS à 1500tr/mn

		TARIF GROUPES ÉLECTROGÈNES 50HZ							
		MOTEUR			OUVERT				
		CONTINU 1500rpm 24h/jour --- 2000h/an							
		R/L/D			A/W			Système de refroidissement	
		D R L			Deutz Lombardini Lister-Petter			A Air	
		RC			A			W Eau	
		Manuel - À distance			A			Automatique AMF panel	
KVA	Données techniques	CAMA T6	CARA T7	CALW T10	CARA T10	CALW T15	CADA T15	KVA	
TECHNIQUES	Norme d'émissions 2002/88	Exempt	Exempt	Exempt	Exempt	Exempt	YES	TECHNICAL DATA	
	Secours / Continu [kVA]	5,5 / 4,7	7 / 6,3	10 / 9	10 / 9	14 / 13	14 / 13		
	Voltage [V] / Intensité [A] / Cos φ	400 / 8 / 0,8	400 / 10 / 0,8	400 / 14 / 0,8	400 / 14 / 0,8	400 / 20 / 0,8	400 / 20 / 0,8		
	Dimensions longueur x largeur x hauteur [mm]	1200/656/880	1200/656/930	1450/750/1050	1250/656/920	1450/750/1050	1450/750/1010		
	Dim emballage long x larg x hauteur [mm]	1300/720/950	1300/720/950	1500/800/1230	1300/720/950	1500/800/1230	1500/800/1230		
	Puissance acoustique LWA [dBA]	111	N.D.	98	99	98	99		
	Pression acoustique LPA [dBA] 16m/10m/7m/4m	79/83/86/91	N.D.	66/70/73/78	67/71/74/79	66/70/73/78	67/71/74/79		
	Réservoir [l] / Autonomie 75% (PRP) [h]	25 / 21	25 / 20	30 / 20	30 / 14	30 / 14	30 / 12		
Unités par container 20' / 40'	12 / 27	12 / 27	10 / 21	12 / 27	10 / 21	10 / 21			
MOTEUR	Code moteur	.241-5007	13033	1348	1298-0005	1434	171	ENGINE	
	Modèle	M608	4LD820/8	LPW2/8	9LD625/8	LPW3/8	F2L2011/8		
	Fabricant	MINSEL	LOMBARDINI	LISTER	LOMBARDINI	DEUTZ	DEUTZ		
	Couplage	Cone Ø30mm	Cone Ø30mm	SAE5 7½	SAE4 7½	SAE5 7½	SAE3 11½		
	Refroidissement / N° cylindres /Aspiration	Air/1/Naturelle	Air/1/Naturelle	Eau/2/Naturelle	Eau/2/Naturelle	Eau/3/Naturelle	Air/2/Naturelle		
RC	Manual-Remote panel	G5 CAMA T6	G5 CARA T7	G5 CALW T10 RC	G5 CARA T10 RC	G5 CALW T15 RC	G5 CADA T15 RC	RC	
	Prix public	6ED0095	13038	2839	6ED0101	3002	6ED0521	Pricing	
	Poid net / Poids avec emballage [kg]	219 / 227	266 / 274	394 / 402	314 / 322	443 / 452	448 / 457		
ALT	Code alternateur	1639	1639	15010	13105	14828	14854	ALT	
	Modèle	T132 XSA	T132 XSA	T132 XSB	T132 XSB	T132 SA	T132 SA		
	Fabricant	SACCARDO	SACCARDO	SACCARDO	SACCARDO	SACCARDO	SACCARDO		
	Système de regulation	COMPOUND	COMPOUND	COMPOUND	COMPOUND	COMPOUND	COMPOUND		
	Alternateur IP protection	IP20	IP20	IP23	IP23	IP23	IP23		
RC	Coffret	Manuel-Distance	Manuel-Distance	Manuel-Distance	Manuel-Distance	Manuel-Distance	Manuel-Distance	RC	
	Carté électronique	GPMR72 + V	GPMR72 + V	GPMR72 + V	GPMR72 + V	GPMR72 + V	GPMR72 + V		
	Coffret de contrôle / Cableage de contrôle	14988/3116	14988/13148	14988/129	14988/129	14988/129	14988/226		
	Coffret de force / Cableage de force	14785/1711	14785/1711	14785/1711	14785/1711	3245/1711	3245/1711		
A	Automatique AMF panel	G5 CAMA T6 A	G5 CARA T7 A	G5 CALW T10 A	G5 CARA T10 A	G5 CALW T15 A	G5 CADA T15 A	A	
	Prix public	Non disponible	Non disponible	5.350 €	Voir page 19	5.957 €	6.496 €	Pricing	
	Poid net / Poids avec emballage [kg]			396 / 405		448 / 457	465 / 480		
ALT	Alternator code			18805		18798	18807	ALT	
	Model			LSA 40 VS1		LSA 40 VS2	LSA 40 VS2		
	Manufacturer			LEROY SOMER		LEROY SOMER	LEROY SOMER		
	Regulation			AVR		AVR	AVR		
	Protection index			IP23		IP23	IP23		
AUTO	Coffret			Automatique AMF		Automatique AMF	Automatique AMF	AUTO	
	Carté électronique			GECO + VI6		GECO + VI6	GECO + VI6		
	Coffret de contrôle / Cableage de contrôle			16745 / 129		16745 / 129	16745 / 226		
	Coffret de force / Cableage de force			16214 / 1711		3245 / 1711	3245 / 1711		
KITS	Kit maint 1000 h Moteur	1430-1150/54€	13327 / 102€	2276 / 108€	3494 / 123€	2278 / 116€	DEU-1080/58€	KITS	
	Kit maint/secours 1000 h Moteur	1430-1152/82€	13328 / 145€	2277 / 143€	3497 / 209€	2279 / 143€	DEU-1093/77€		
	Kit maint/secours 1000 h Alternateur (T132)	1893 / 118€	1893 / 118€	-	1893 / 118€	1893 / 118€	1893 / 118€		
Options	Options disponible (Code / Prix public)							Options	
ALT	AVR: NSM AVR alternator for "RC" models	N.D.	N.D.	15130 / 345€	N.D.	15070 / 415€	N.D.	ALT	
	LSA: Leroy Somer alternator for "A" models	N.D.	N.D.	SERIE	Page 19	SERIE	15543 / 330€		
	LSA-TR: Leroy Somer tropicalized	N.D.	N.D.	XXXXX / 265€	Page 19	XXXXX / 265€	XXXXX / 265€		
	LSA-PMG: Leroy Somer PMG system	N.D.	N.D.	Consulter	Consulter	Consulter	Consulter		
	LSACALD: Leroy Somer with preheating	N.D.	N.D.	XXXXX / 215€	Page 19	XXXXX / 215€	XXXXX / 215€		
INS/ATS	1ATS: Integrated ATS for RC models	N.D.	N.D.	N.D.	N.D.	N.D.	N.D.	INS/ATS	
	1ATS: Separated ATS for RC models	1976 / 170€	1976 / 170€	1976 / 170€	1976 / 170€	1976 / 170€	1976 / 170€		
	2ATS: Separated ATS for A models	N.D.	N.D.	1977 / 212€	1977 / 212€	1977 / 212€	1977 / 212€		
Coffret	TEMP: Automatic start/stop clock for RC	3017 / 131€	3017 / 131€	3017 / 131€	3017 / 131€	3017 / 131€	3017 / 131€	Coffret	
	220V: Output 220V voltage for RC models	Consulter	Consulter	Page 19	Page 19	Page 19	15393 / 58 €		
	220V: Output 220V voltage for A models	Consulter	Consulter	Page 19	Page 19	Page 19	15394 / 42 €		
	GPM2: GM2 controller (A-V/A-F/V-F)	N.D.	N.D.	N.D.	N.D.	N.D.	N.D.		
	GPM3: GPM3 digital controller for RC models	N.D.	N.D.	14231 / 230 €	N.D.	14231 / 230 €	14231 / 230 €		
	GECO-MD: GECOMD digital for A models	N.D.	N.D.	14240 / 292 €	Page 19	14240 / 292 €	14240 / 292 €		
	AMF25: AMF25 digital for A with EMR	N.D.	N.D.	14184 / 453 €	N.D.	14184 / 453 €	14184 / 453 €		
	PROTDIF: Differential protection A models	N.D.	N.D.	15437 / 76€	15437 / 76€	15438 / 76€	15438 / 76€		
	BASES: Shokets for RC models	SERIE	SERIE	SERIE	SERIE	N.D.	N.D.		
	DESCBAT: Battery disconnecter	15345 / 88€	15345 / 88€	15345 / 88€	15345 / 88€	15345 / 88€	15345 / 88€		
Moteur	VDO: Press & Temp transmitt. (GPM3/AMF25)	1337 / 97€	1337 / 97€	Page 19	Page 19	Page 19	15967 / 130 €	Moteur	
	EMR-A: Engine electronic governor for A	N.D.	N.D.	N.D.	N.D.	N.D.	15276 / 1102€		
	EMR-RC: Engine electronic governor for RC	N.D.	N.D.	N.D.	N.D.	N.D.	15269 / 810 €		
	EMR-BUS: Engine MODBUS (needs AMF25)	N.D.	N.D.	N.D.	N.D.	N.D.	15349 / 325 €		
	AIRCALD: Air pre-heating for RC models	N.D.	N.D.	13095 / 80 €	Page 19	13095 / 80 €	13098 / 155 €		
	AIRCALD: Air pre-heating for A models	N.D.	N.D.	11777 / 165 €	Page 19	11777 / 165 €	13041 / 243 €		
	OILCALD: Oil pre-heating	3139 / 261€	15993 / 228€	N.D.	N.D.	N.D.	N.D.		
	LIQCALD: Liquid pre-heating	N.D.	N.D.	Page 19	Page 19	Page 19	N.D.		
Inst	RESID: Residential muffler	N.D.	N.D.	N.D.	N.D.	Page 19	3465 / 198€	Inst	
	2.5FLEX50: 2,5m flexible tube for silencer	...934-032/55€	...934-032/55€	...934-032/55€	...934-032/55€	...934-032/55€	...934-032/55€		
	5FLEX50: 5m flexible tube for silencer	...934-033/93€	...934-033/93€	...934-033/93€	...934-033/93€	...934-033/93€	...934-033/93€		
Chariot	C.OBRA: Not approved trailer	1 Axle / Ball	1 Axle / Ball	Page 19	Page 19	Page 19	1 Axle / Ball	Chariot	
	C.ART: Articulated rod	3487 / 850€	3487 / 850€	Page 19	Page 19	Page 19	3138 / 947€		
	C.ARG: Ring type coupling	Consulter	Consulter	Page 19	Page 19	Page 19	Consult us		
Comb	DECCOMB: Fuel decanter	15335 / 40€	15335 / 40€	Page 19	Page 19	Page 19	15335 / 40€	Comb	
	190L: Extra large 190L fuel tank	N.D.	N.D.	SERIE	N.D.	SERIE	15970 / 361€		
	B-TR-MN: Semi-Automatic fuel electropump	N.D.	N.D.	Page 19	N.D.	Page 19	18083 / 391€		
	B-TR-AU: Automatic fuel electropump	Consulter	Consulter	Page 19	Page 19	Page 19	15432 / 500€		



GRUPOS OUVERTS = TRIPHASÉS à 1500tr/mn

TARIF GRUPOS ELECTROGENOS 50HZ							
G5	CONTINU			OUVERT			
C	1500rpm 24h/jour --- 2000h/an			A			
R/L/D	D	R	L	A/W		Système de refroidissement	
	MOTEUR			Deutz Lombardini Lister-Petter		Air	
RC	Manuel - à distance			A		Automatique AMF panel	
	W			Eau		Eau	

50 HERTZ

1500 RPM

KVA	Données techniques	CARA T20	CALW T20	CADW T25	CADA T25	CADA T35	CALW T35	KVA	
DONNEES TECHNIQUES	Norme d'émissions 2002/88	YES	YES	YES	YES	YES	NO	DONNEES TECHNIQUES	
	Secours / Continu [kVA]	20 / 18	19,5 / 17,5	25 / 23	25 / 23	35 / 31,5	35 / 31,5		
	Voltage [V] / Intensité [A] / Cos φ	400 / 28 / 0,8	400 / 28 / 0,8	400 / 36 / 0,8	400 / 36 / 0,8	400 / 50 / 0,8	400 / 50 / 0,8		
	Dimensions longueur x largeur x hauteur [mm]	1450/750/1050	1450/750/1050	1450/750/1010	1450/750/1010	1630/850/1150	1630/850/1150		
	Dim emballage long x larg x hauteur [mm]	1500/800/1230	1500/800/1230	1500/800/1230	1500/800/1230	1700/940/1210	1700/940/1210		
	Puissance acoustique LWA [dBA]	100	100	98	100	103	N.D.		
	Pression acoustique LPA [dBA] 16m/10m/7m/4m	68/72/75/80	68/72/75/80	66/70/73/78	68/72/75/80	71/75/78/83	N.D.		
	Réservoir [l] / Autonomie 75% (PRP) [h]	30 / 9	30 / 10	30 / 8	30 / 8	60 / 11	60 / 10		
Unités par container 20' / 40'	10 / 21	10 / 21	10 / 21	10 / 21	6 / 14	6 / 14			
MOTEUR	Code moteur	1428-0002	1435	18477	197	199	14961	MOTEUR	
	Modèle	11LD626/8	LPW4/8	D2009L04	F3L2011/8	F4L2011/8	DWS4-03/8		
	Fabricant	LOMBARDINI	LISTER	DEUTZ	DEUTZ	DEUTZ	LISTER		
	Couplage	SAE 4 7½	SAE5 7½	SAE5 7½	SAE3 11½	SAE3 11½	SAE3 11½		
	Refroidissement / N° cylindres / Aspiration	Air/4/Naturelle	Eau/4/Naturelle	Eau/4/Naturelle	Air/3/Naturelle	Air/4/Naturelle	Eau/4/Naturelle		
RC	Manual-Remote panel	G5 CARA T20 RC	G5 CALW T20 RC	G5 CADW T25 RC	G5 CADA T25 RC	G5 CADA T35 RC	G5 CALW T35 RC	RC	
	Prix public	Code groupe électrogène	3729	2091	N.D.	GED0514	GED0520		14962
	Prix public	Prix public	5.897 €	6.261 €		7.113 €	7.732 €		7.875 €
ALT	Code alternateur	2996	1642		1641	2565	2565	ALT	
	Modèle	T132 MA	T132 MA		T132 LA	T132 LB	T132 LB		
	Fabricant	SACCARDO	SACCARDO		SACCARDO	SACCARDO	SACCARDO		
RC	Coffret	Manuel-Distance	Manuel-Distance		Manuel-Distance	Manuel-Distance	Manuel-Distance	RC	
	Carté électronique	GPMR72+V	GPMR72+V		GPMR72 + V	GPMR72 + V	GPMR72 + V		
	Coffret de contrôle / Cableage de contrôle	14988/3585	14988/129		14988/226	14988/226	14988/129		
A	Automatique AMF panel	G5 CARA T20 A	G5 CALW T20 A	G5 CADW T25 A	G5 CADA T25 A	G5 CADA T35 A	G5 CALW T35 A	A	
	Prix public	Code groupe électrogène	Voir page 19	2114	18357	GED0547	GED0563		15015
	Prix public	Prix public		6.790 €	7.695 €	7.650 €	8.389 €		8.475 €
ALT	Alternator code	18803	18802		18808	1151	1151	ALT	
	Model	LSA40 S4	LSA 40 L7		LSA 40 L7	LSA 42.2 L9	LSA 42.2 L9		
	Manufacturer	LEROY SOMER	LEROY SOMER		LEROY SOMER	LEROY SOMER	LEROY SOMER		
AUTO	Coffret	Automatic AMF	Automatic AMF		Automatic AMF	Automatic AMF	Automatic AMF	AUTO	
	Carté électronique	GECO + V	GECO + V		GECO + V	GECO + V	GECO + V		
	Coffret de contrôle / Cableage de contrôle	16745/129	16745/18526		16745/226	16745/226	16745/129		
KITS	Kit mant 1000 h MOTEUR	3498 / 128€	2278 / 116€	Consulter	DEU-1080/58€	DEU-1080/58€	657-76130 / 280€	KITS	
	Kit mant/secours 1000 h MOTOR	3499 / 280€	2279 / 143€	Consulter	DEU-1093/77€	DEU-1093/77€	15527 / 358€		
	Kit mant/secour 1000 h ALT (T132)	1893 / 118€	1893 / 118€	-	1893 / 118€	1893 / 118€	1893 / 118€		
Options disponibles (Code / Prix public)									
ALT	AVR: NSM AVR alternator	Page 19	2492 / 395€	N.D.	1000-5202/171€	1000-5204/539€	1000-5204/539€	ALT	
	LSA: Leroy Somer alternator	Page 19	SERIE	SERIE	15544 / 171€	SERIE	SERIE		
	LSA-TR: Leroy Somer tropicalized	Page 19	XXXXX / 265€	XXXXX / 265€	15307 / 271€	14175 / 271€	14175 / 271€		
	LSA-PMG: Leroy Somer PMG system	Consulter	Consulter	Consulter	Consulter	Consulter	Consulter		
	LSACALD: Leroy Somer with preheating	Page 19	XXXXX / 215€	XXXXX / 215€	12839 / 162€	14251 / 162€	14251 / 162€		
INS/ATS	1ATS: Integrated ATS for RC models	N.D.	N.D.	N.D.	N.D.	N.D.	N.D.	INS/ATS	
	2ATS: Separated ATS for RC models	1976 / 170€	1976 / 170€	1976 / 170€	1976 / 170€	1989 / 294€	1989 / 294€		
	2ATS: Separated ATS for A models	1977 / 212€	1977 / 212€	1977 / 212€	1977 / 212€	1999 / 479€	1999 / 479€		
Coffret	TEMP: Automatic start/stop clock for RC	3017 / 131€	3017 / 131€	3017 / 131€	3017 / 131€	3017 / 131€	3017 / 131€	Coffret	
	220V: Output 220V voltage for RC models	Page 19	Page 19	Page 19	Page 19	15448 / 56€	15450 / 94€		
	220V: Output 220V voltage for A models	Page 19	Page 19	Page 19	Page 19	15449 / 51€	15451 / 47€		
	GPM2: GPM2 controller (A-V/A+F/V+F)	N.D.	N.D.	N.D.	N.D.	N.D.	N.D.		
	GPM3: GPM3 digital controller for RC models	N.D.	N.D.	N.D.	N.D.	14231 / 230€	14231 / 230€		
	GECO-MD: GECOMD digital for A models	Page 19	Page 19	14240 / 292€	14240 / 292€	14240 / 292€	14240 / 292€		
	AMF25: AMF25 digital for A with EMR	Page 19	Page 19	14184 / 453€	14184 / 453€	14184 / 453€	14184 / 453€		
	PROTDIF: Differential protection A models	15439 / 80€	15439 / 80€	15440 / 80€	15440 / 80€	15441 / 89€	15441 / 89€		
	BASES: Shokets for RC models	N.D.	N.D.	N.D.	N.D.	N.D.	N.D.		
	DESCBAT: Battery disconnecter	Page 19	Page 19	15345 / 88€	15345 / 88€	15345 / 88€	15345 / 88€		
Moteur	VDO: Press & Temp transmitt. (GPM3/AMF25)	Page 19	Page 19	Page 19	15965 / 93€	15967 / 130€	Consulter	Moteur	
	EMR-A: Engine electronic governor for A	N.D.	N.D.	N.D.	15277 / 1102€	15288 / 1102€	N.D.		
	EMR-RC: Engine electronic governor for RC	N.D.	N.D.	N.D.	15271 / 810€	15022 / 810€	N.D.		
	EMR-BUS: Engine MODBUS (needs AMF25)	N.D.	N.D.	N.D.	15349 / 325€	15349 / 325€	15349 / 325€		
	AIRCALD: Air pre-heating for RC models	Page 19	13095 / 80€	13095 / 80€	13098 / 155€	13098 / 155€	13098 / 155€		
	AIRCALD: Air pre-heating for A models	Page 19	11777 / 165€	11777 / 165€	13041 / 243€	13041 / 243€	13041 / 243€		
	OILCALD: Oil pre-heating	N.D.	N.D.	N.D.	N.D.	N.D.	N.D.		
LIQCALD: Liquid pre-heating	N.D.	Page 19	Page 19	N.D.	N.D.	13086 / 482€			
Inst	RESID: Residential muffler	Page 19	Page 19	Page 19	3465 / 198€	3465 / 198€	15284 / 198€	Inst	
	2.5FLEX50: 2,5m flexible tube for silencer	...934-032/55€	...934-032/55€	...934-032/55€	...934-032/55€	...934-032/55€	...934-032/55€		
	5FLEX50: 5m flexible tube for silencer	...934-033/93€	...934-033/93€	...934-033/93€	...934-033/93€	...934-033/93€	...934-033/93€		
Chariot	C.OBRA: Not approved trailer	1 Axle / Ball	Page 19	Page 19	1 Axle / Ball	1 Axle / Ball	1 Axle / Ball	Chariot	
	C.ART: Articulated rod	3138/947€	Page 19	Page 19	3138/947€	3488/1.062€	3488/1.062€		
	C.ARG: Ring type coupling	Consulter	Page 19	Page 19	Consulter	Consulter	Consulter		
Comb	DECCOMB: Fuel decanter	N.D.	SERIE	N.D.	15970 / 362€	15970 / 362€	SERIE	Comb	
	190L: Extra large 190L fuel tank	N.D.	Page 19	Page 19	17162 / 391€	17162 / 391€	N.D.		
	B-TR-MN: Semi-Automatic fuel electropump	15432 / 500€	Page 19	Page 19	15432 / 500€	15432 / 500€	15432 / 500€		
B-TR-AU: Automatic fuel electropump	15433 / 542€	Page 19	Page 19	15433 / 542€	15433 / 542€	15433 / 542€			



GROUPES OUVERTS = TRIPHASÉS à 1500tr/mn							
G5				TARIF GROUPES ÉLECTROGENES 50HZ			
C		CONTINU		A		OUVERT	
1500rpm 24h/jour --- 2000h/an		MOTEUR		Système de refroidissement		Air	
R/L/D	D	R	L	A/W	A	W	Eau
Deutz Lombardini Lister-Petter				Automatique AMF panel			
RC				A			
Manuel - À distance				Automatique AMF panel			

50 HERTZ

1500 RPM

KVA	Données techniques	CADA T47	CADA T47	CADA T66	CADO T65	CADW T100	CADW T115	KVA	
TECHNIQUES	Norme d'émissions 2002/88	YES	NO	NO	YES	NO	YES	DONNÉES TECHNIQUES	
	Secours / Continu [kVA]	47 / 40	47 / 40	66 / 60	65/58	100 / 90	115 / 104		
	Voltage [V] / Intensité [A] / Cos φ	400 / 67 / 0,8	400 / 67 / 0,8	400 / 95 / 0,8	400 / 93 / 0,8	400 / 145 / 0,8	400 / 166 / 0,8		
	Dimensions longueur x largeur x hauteur [mm]	1630/850/1160	1630/850/1160	1900/850/1200	1900/850/1200	2135/860/1550	2135/860/1550		
	Dim emballage long x larg x hauteur [mm]	1700/940/1210	1700/940/1210	1970/940/1240	1970/940/1240	2230/1070/1550	2230/1070/1550		
	Puissance acoustique LWA [dBA]	97	104	107	100	111	113		
	Pression acoustique LPA [dBA] 16m/10m/7m/4m	65/69/72/77	72/77/79/82	75/79/82/87	68/72/76/80	79/83/86/91	81/85/88/93		
	Réservoir [l] / Autonomie 75% (PRP) [h]	60 / 8	60 / 8	140 / 13	140 / 13	140 / 9	140 / 8		
Unités par container 20' / 40'	6 / 14	6 / 14	6 / 12	6 / 12	5 / 11	5 / 11			
MOTEUR	Code moteur	201	DEU-0007	DEU-0012	16013	999	714	MOTEUR	
	Modèle	BF4L2011	F4L912	F6L912	BF4M2011C	BF4M1013E	BF4M1013EC		
	Fabricant	DEUTZ	DEUTZ	DEUTZ	DEUTZ	DEUTZ	DEUTZ		
	Couplage	SAE3 11½	SAE3 11½	SAE3 11½	SAE3 11½	SAE2 11½	SAE2 11½		
	Refroidissement / N° cylindres / Aspiration	Air/4/Turbo	Air/4/Naturelle	Air/6/Naturelle	Huile/4/Turbo	Eau/4/Turbo	Eau/4/Turbo		
	Code alternateur	1134	1134	642	642	392	392		
ALT	Modèle	LSA43.2S15	LSA43.2S15	LSA43.2M45	LSA43.2M45	LSA44.2VS45	LSA44.2VS45	ALT	
	Fabricant	LEROY SOMER	LEROY SOMER	LEROY SOMER	LEROY SOMER	LEROY SOMER	LEROY SOMER		
	Système de regulation	AVR	AVR	AVR	AVR	AVR	AVR		
	Alternateur IP protection	IP23	IP23	IP23	IP23	IP23	IP23		
RC	Manuel / À distance - RC	G5 CADA T47 RC	G5 CADA-912 T47RC	G5 CADA T66 RC	G5 CADO T65 RC	G5 CADW T100 RC	G5 CADW T115 RC	RC	
	Prix public	Code groupe électrogène	GED0513	3281	GED0524	17221	998		671
	Prix public	Prix public	9.176 €	9.475 €	11.129 €	11.150 €	14.702 €		16.182 €
RC	Coffret	Manual-Remote	Manual-Remote	Manual-Remote	Manual-Remote	Manual-Remote	Manual-Remote	RC	
	Carté électronique	GPMR72 + V	GPMR72 + V	GPMR72 + V	GPM3	GPM3	GPM3		
	Coffret de contrôle / Cableage de contrôle	14988/226	14988/358	14988/358	16169/646	16169/646	16169/646		
A	Automatique AMF panel - A	G5 CADA T47 A	G5 CADA-912 T47A	G5 CADA T66 A	G5 CADO T65 A	G5 CADW T100 A	G5 CADW T115 A	A	
	Prix public	Code groupe électrogène	GED0504	3284	GED0541	17222	1009		1013
	Prix public	Prix public	9.308 €	9.542 €	11.183 €	11.190 €	14.615 €		16.064 €
AUTO	Coffret	Automatic AMF	Automatic AMF	Automatic AMF	Automatic AMF	Automatic AMF	Automatic AMF	AUTO	
	Carté électronique	GECO + V	GECO + V	GECO + V	GECO MD	GECO MD	GECO MD		
	Coffret de contrôle / Cableage de contrôle	16745/226	16745/358	16745/358	14840/646	14840/646	14840/646		
KITS	Kit maint 1000 h MOTEUR	DEU-1090/116€	DEU-1086/108€	DEU-1089/133€	DEU-1090/116€	DEU-1114/161€	DEU-1114/161€	KITS	
	Kit maint/secours 1000 h MOTEUR	DEU-1109/136€	DEU-1085/151€	DEU-1100/167€	DEU-1109/136€	DEU-1115/272€	DEU-1115/272€		
	Kit maint/secours 1000 h ALTERNATEUR	-	-	-	-	-	-		

Options disponible (Code / Prix public)								Options
ALT	AVR: NSM AVR alternator	SERIE	SERIE	SERIE	SERIE	SERIE	SERIE	ALT
	LSA: Leroy Somer alternator	SERIE	SERIE	SERIE	SERIE	SERIE	SERIE	
	LSA-TR: Leroy Somer tropicalized	14176 / 271€	14176 / 271€	12419 / 271€	12419 / 271€	15309 / 280€	15309 / 280€	
	LSA-PMG: Leroy Somer PMG system	Consulter	Consulter	Consulter	Consulter	Consulter	Consulter	
INS/ATS	LSACALD: Leroy Somer with preheating	15153 / 215€	15153 / 215€	15489 / 215€	15489 / 215€	15155 / 215€	15155 / 215€	INS/ATS
	1ATS: Separated ATS for RC models	1989 / 294€	1989 / 294€	1989 / 294€	1989 / 294€	3262 / 477€	3262 / 477€	
	2ATS: Separated ATS for A models	1999 / 479€	1999 / 479€	1999 / 479€	1999 / 479€	3265 / 920€	3265 / 920€	
Coffret	TEMP: Automatic start/stop clock for RC	3017 / 131€	3017 / 131€	3017 / 131€	3017 / 131€	3017 / 131€	3017 / 131€	Coffret
	220V: Output 220V voltage for RC models	15452 / 185€	15452 / 185€	15454 / 409€	15454 / 409€	15456 / 610€	15458 / 745€	
	220V: Output 220V voltage for A models	15453 / 105€	15453 / 105€	15455 / 375€	15455 / 375€	15457 / 572€	15459 / 725€	
	GPM2: GM2 controller (A+V/A+F/V+F)	N.D.	N.D.	N.D.	N.D.	N.D.	N.D.	
	GPM3: GPM3 digital controller for RC models	14231 / 230€	14231 / 230€	14231 / 230€	SERIE	SERIE	SERIE	
	GECO-MD: GECOMD digital for A models	14240 / 292€	14240 / 292€	14240 / 292€	SERIE	SERIE	SERIE	
	AMF25: AMF25 digital for A with EMR	14184 / 453€	14184 / 453€	14184 / 453€	15023 / 161€	15023 / 161€	15023 / 161€	
	PROTDIF: Differential protection A models	15442 / 93€	15442 / 93€	15443 / 153€	15443 / 153€	15444 / 156€	15445 / 187€	
	BASES: Shokets for RC models	N.D.	N.D.	N.D.	N.D.	N.D.	N.D.	
	DESCBAT: Battery disconnecter	15345 / 88€	15345 / 88€	15345 / 88€	15345 / 88€	15345 / 88€	15345 / 88€	
Moteur	VDO: Press & Temp transmitt. (GPM3/AMF25)	15967 / 130€	Consulter	Consulter	15967 / 130€	15968 / 140€	15968 / 140€	Moteur
	EMR-A: Engine electronic governor for A	15289 / 1.069€	N.D.	N.D.	XXXX / 786€	15217/1107€	15218/1107€	
	EMR-RC: Engine electronic governor for RC	14886 / 786€	N.D.	N.D.	XXXX / 786€	15217/1107€	15218/1107€	
	EMR-BUS: Engine MODBUS (needs AMF25)	15349 / 325€	15349 / 325€	15349 / 325€	15349 / 325€	15349 / 325€	15349 / 325€	
	AIRCALD: Air pre-heating for RC models	SERIE	N.D.	N.D.	SERIE	N.D.	N.D.	
	AIRCALD: Air pre-heating for A models	SERIE	N.D.	N.D.	SERIE	N.D.	N.D.	
Inst	OILCALD: Oil pre-heating	N.D.	3363 / 228€	3363 / 228€	N.D.	N.D.	N.D.	Inst
	LIQCALD: Liquid pre-heating	N.D.	N.D.	N.D.	N.D.	13081 / 411€	13081 / 411€	
	RESID: Residential muffler	3465 / 198€	Consulter	Consulter	3465 / 198€	15971 / 515€	15971 / 515€	
Chariot	2,5FLEX50: 2,5m flexible tube for silencer	...934-032 / 53€	N.D.	17629 / 58€	12874 / 56€	12874 / 56€	12874 / 56€	Chariot
	5FLEX50: 5m flexible tube for silencer	...934-033 / 90€	N.D.	17630 / 95€	12875 / 98€	12875 / 98€	12875 / 98€	
	C.OBRA: Not approved trailer	3488/1062€	3488/1062€	3489/1084€	3489/1084€	3489/1084€	3489/1084€	
	C.ART: Articulated rod	Consulter	Consulter	Consulter	Consulter	Consulter	Consulter	
Comb	C.ARG: Ring type coupling	15335 / 40€	15335 / 40€	15335 / 40€	15335 / 40€	15335 / 40€	15335 / 40€	Comb
	DECCOMB: Fuel decanter	15970 / 361€	15970 / 361€	Consulter	15970 / 361€	SERIE	SERIE	
	235L: 47KVA / 250L: 100-115KVA	17162 / 391€	Consulter	Consulter	Consulter	12201 / 421€	12201 / 421€	
	550L: 66KVA / 645L: 100-115KVA	Consulter	Consulter	16483 / 469€	Consulter	16482 / 469€	16482 / 469€	
Comb	B-TR-MN: Semi-Automatic fuel electropump	15432 / 500€	15432 / 500€	15432 / 500€	15432 / 500€	15432 / 500€	15432 / 500€	Comb
	B-TR-AU: Automatic fuel electropump	15433 / 542€	15433 / 542€	15433 / 542€	15433 / 542€	15433 / 542€	15433 / 542€	



GROUPES OUVERTS = TRIPHASÉS à 1500tr/mn				
G5	TARIF GROUPES ÉLECTROGENES 50HZ			
C	CONTINU 1500rpm 24h/jour --- 2000h/an	A		OUVERT
R/L/D	D R L	Deutz Lombardini Lister-Petter	A/W	Système de refroidissement A W Air Eau
RC	Manuel - À distance		A	Automatique AMF panel

50
HERTZ

1500
RPM

KVA	<i>Données techniques</i>	CADW T140	CADW T175	CADW T200	CADW T275	KVA		
TECHNIQUES DONNEES TECHNIQUES	Norme d'émissions 2002/88	YES	YES	YES	YES	TECHNIQUES DONNEES TECHNIQUES		
	Secours / Continu [kVA]	140 / 125	175 / 157	200 / 180	275 / 250			
	Voltage [V] / Intensité [A] / Cos φ	400 / 200 / 0,8	400 / 250 / 0,8	400 / 288 / 0,8	400 / 396 / 0,8			
	Dimensions longueur x largeur x hauteur [mm]	2135/860/1550	2600/1050/1650	2930/1100/1750	2930/1100/1750			
	Dim emballage long x larg x hauteur [mm]	2230/1070/1550	2620/1100/1700	2950/1160/1800	2950/1160/1800			
	Puissance acoustique LWA [dBA]	105	116	116	112			
	Pression acoustique LPA [dBA] 16m/10m/7m/4m	73/77/80/85	84/88/91/96	84/88/91/96	80/84/87/92			
	Réservoir [l] / Autonomie 75% (PRP) [h]	140 / 6	200 / 8	310 / 10	310 / 8			
Unités par container 20' / 40'	5 / 11	4 / 9	4 / 8	4 / 8				
MOTEUR	Code moteur	17496	2853	13834	14482	MOTEUR		
	Modèle	BF4M1013FC	BF6M1013EC	BF6M1013FP	TCD2013L064			
	Fabricant	DEUTZ	DEUTZ	DEUTZ	DEUTZ			
	Couplage	SAE2 11½	SAE2 11½	SAE2 11½	SAE2 11½			
	Refroidissement / N° cylindres / Aspiration	Eau/4/Turbo	Eau/6/Turbo	Eau/6/Turbo	Eau/6/C.Rail			
ALT	Code alternateur	639	2121	13724	407	ALT		
	Modèle	LSA 44.2 S75	LSA 44.2 L12	LSA 46.2 M3	LSA 46.2 L6			
	Fabricant	LEROY SOMER	LEROY SOMER	LEROY SOMER	LEROY SOMER			
	Système de regulation	AVR	AVR	AVR	AVR			
	Alternateur IP protection	IP23	IP23	IP23	IP23			
RC	<i>Manuel / À distance - RC</i>	G5 CADW T140 RC	G5 CADW T175 RC	G5 CADW T200 RC	G5 CADW T275 RC	RC		
	Prix public	Code groupe électrogène 17498 Prix public 18.560 € Poid net / Poids avec emballage [kg] 1500 / 1550	Code groupe électrogène 2170 Prix public 21.318 € Poid net / Poids avec emballage [kg] 1900 / 1930	Code groupe électrogène 14266 Prix public 26.416 € Poid net / Poids avec emballage [kg] 1990 / 2010	Code groupe électrogène 14413 Prix public 28.757 € Poid net / Poids avec emballage [kg] 2190 / 2210			
RC	<i>Coffret</i>	Manuel-Distance	Manuel-Distance	Manuel-Distance	Manuel-Distance	RC		
	Carté électronique	GPM3	GPM3	GPM3	GPM3			
	Coffret de contrôle / Cableage de contrôle	14001/18472	16169/2973	14001/3064	14001/14699			
	Coffret de force / Cableage de force	2418/1755	2418/2417	14999/2417	14999/2417			
A	<i>Automatique AMF panel - A</i>	G5 CADW T140 A	G5 CADW T175 A	G5 CADW T200 A	G5 CADW T275 A	A		
	Prix public	Code groupe électrogène 18568 Prix public 18.550 € Poid net / Poids avec emballage [kg] 1500 / 1550	Code groupe électrogène 3655 Prix public 21.194 € Poid net / Poids avec emballage [kg] 1900 / 1930	Code groupe électrogène 13833 Prix public 26.380 € Poid net / Poids avec emballage [kg] 1990 / 2010	Code groupe électrogène 14414 Prix public 28.722 € Poid net / Poids avec emballage [kg] 2190 / 2210			
	AUTO	<i>Coffret</i>	Automatique AMF	Automatique AMF	Automatique AMF		Automatique AMF	AUTO
		Carté électronique	GECO-MD	GECO-MD	GECO-MD		GECO-MD	
Coffret de contrôle / Cableage de contrôle		16749/18472	14840/2973	16749/3064	16766/14699			
Coffret de force / Cableage de force		2865/1755	2865/2417	14997/2417	2876 / 2417			
KITS	Kit maint 1000 h MOTEUR	Consulter	DEU-1117/203€	DEU-1119/217€	15495 / 658€	KITS		
	Kit maint/secour 1000 h MOTEUR	Consulter	DEU-1118/315€	DEU-1120/328€	15329 / 769€			
	Kit maint/secour 1000 h ALTERNATEUR	-	-	-	-			
Options	<i>Available options (Code / Retail price)</i>					Options		
ALT	AVR: NSM AVR alternator	SERIE	SERIE	SERIE	SERIE	ALT		
	LSA: Leroy Somer alternator	SERIE	SERIE	SERIE	SERIE			
	LSA-TR: Leroy Somer tropicalized	15310 / 280€	15311 / 280€	15312 / 309€	15313 / 309€			
	LSA-PMG: Leroy Somer PMG system	Consulter	Consulter	Consulter	Consulter			
	LSACALD: Leroy Somer with preheating	15491 / 215€	15492 / 215€	15493 / 215€	15494 / 215€			
INS/ATS	1ATS: Separated ATS for RC models	3262 / 477€	3262 / 477€	2982 / 827€	15348/1000€	INS/ATS		
	2ATS: Separated ATS for A models	3265 / 920€	3265 / 920€	12956 / 1644€	12956/1644€			
Coffret	TEMP: Automatic start/stop clock for RC	3017 / 131€	3017 / 131€	3017 / 131€	3017 / 131€	Coffret		
	220V: Output 220V voltage for RC models	15460 / 443€	N.D.	N.D.	N.D.			
	220V: Output 220V voltage for A models	15461 / 430€	N.D.	N.D.	N.D.			
	GPM2: GM2 controller (A+V/A+F+V+F)	N.D.	N.D.	N.D.	N.D.			
	GPM3: GPM3 digital controller for RC models	SERIE	SERIE	SERIE	SERIE			
	GECO-MD: GECOMD digital for A models	SERIE	SERIE	SERIE	SERIE			
	AMF25: AMF25 digital for A with EMR	15023 / 161€	15023 / 161€	15023 / 161€	15023 / 161€			
	PROTDIF: Differential protection A models	15446 / 194€	15446 / 194€	15447 / 208€	15447 / 208€			
	BASES: Shokets for RC models	N.D.	N.D.	N.D.	N.D.			
	DESCBAT: Battery disconnecter	15345 / 88€	15345 / 88€	15345 / 88€	15345 / 88€			
Moteur	VDO: Press & Temp transmitt. (GPM3/AMF25)	Needs EMRBUS option	15968 / 140€	Needs EMRBUS option	Needs EMRBUS option	Moteur		
	EMR-A: Engine electronic governor for A	SERIE	12613 / 1006€	SERIE	SERIE			
	EMR-RC: Engine electronic governor for RC	SERIE	12613 / 1006€	SERIE	SERIE			
	EMR-BUS: Engine MODBUS (needs AMF25)	15349 / 325€	15349 / 325€	15349 / 325€	15349 / 325€			
	AIRCALD: Air pre-heating for RC models	N.D.	N.D.	N.D.	N.D.			
	AIRCALD: Air pre-heating for A models	N.D.	N.D.	N.D.	N.D.			
	OILCALD: Oil pre-heating	N.D.	N.D.	N.D.	N.D.			
	LIQCALD: Liquid pre-heating	13081 / 411€	13081 / 411€	13081 / 411€	17854 / 411€			
Inst	RESID: Residential muffler	15971 / 515€	15971 / 515€	15972 / 721€	15972 / 721€	Inst		
	2_5FLEX90: 2,5m flexible tube for silencer	3352 / 86€	3352 / 86€	3352 / 86€	N.D.			
	5FLEX90: 5m flexible tube for silencer	14339 / 148€	14339 / 148€	14339 / 148€	N.D.			
	2_5FLEX120: 2,5m flexible tube for silencer	N.D.	N.D.	N.D.	15326 / 122€			
	5FLEX120: 5m flexible tube for silencer	N.D.	N.D.	N.D.	15327 / 226€			
Chariot	C.OBRA: Not approved trailer	Consulter	Consulter	Consulter	Consulter	Chariot		
	C.ART: Articulated rod	Consulter	Consulter	Consulter	Consulter			
	C.ARG: Ring type coupling	SERIE	SERIE	SERIE	SERIE			
Comb	DECCOMB: Fuel decanter	SERIE	SERIE	SERIE	SERIE	Comb		
	XXXL: Extra large fuel tanks	Consulter	Consulter	Consulter	Consulter			
	B-TR-MN: Semi-Automatic fuel electropump	15432 / 500€	15432 / 500€	15432 / 500€	15432 / 500€			
	B-TR-AU: Automatic fuel electropump	15433 / 542€	15433 / 542€	15433 / 542€	15433 / 542€			

Groupes ouverts 1500tr/mn - 24h/jour - 2000h/an

Groupes ouverts INSONORIZABLE 1500tr/mn - 24h/jour - 2000h/an



Groupes ouverts INSONORIZABLE 1500tr/mn - 24h/jour - 2000h/an



Groupes ouverts (Possibility of soundproofing) = MONOPHASE 1500 tr/mn

G5	GROUPES ÉLECTROGÈNES 50HZ					
C	CONTINU 1500rpm 24h/día --- 2000h/año			A Open with possibility of soundproofing		
L/D	MOTEUR			SYSTÈME DE REFRIGÉRISSMENT		
	L	Lister-Petter		W/O	W	EAU
	D	Deutz			A	AIR
				O	HUILE	

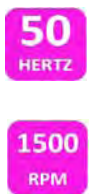

KVA	<i>Données techniques</i>	CALW M9	CALW M13	CALW M16	CADW M21	CADO M31	CADO M42	KVA
TECHNIQUES	Normé d'émissions 2002/88	Exempt	Exempt	Exempt	YES	OUI	OUI	TECHNIQUES
	Normé acoustique 2000/14/CE	OUI	OUI	OUI	OUI	NON	NON	
	Secours / Continue [kVA]	9 / 8	13 / 11	16 / 14	20,6 / 18	30,5 / 28	42 / 38	
	Voltage [V] / Intensité [A] / Cos φ	230/39/0,9	230/56/0,9	230/69/0,9	230/91/0,9	230/132/0,9	230/180/0,9	
	Dimensions longueur x largeur x hauteur [mm]	1800/740/1170	1800/740/1170	1800/740/1170	1800/740/1170	2250/950/1250	2250/950/1250	
	Dim emballage long x largeur x hauteur [mm]	1800/750/1170	1800/750/1170	1800/750/1170	1800/750/1170	2300/1000/1250	2300/1000/1250	
	Puissance acoustique LWA [dBA]	96	96	97	96	99	99	
	Pression acoustique LPA [dBA]16m/10m/7m/4m	64/68/71/76	64/68/71/76	65/69/72/77	64/68/71/76	67/71/74/79	67/71/74/79	
	Réservoir [l] / Autonomie 75% (PRP) [h]	50 / 33	50 / 23	50 / 17	50 / 12,5	100 / 17	100 / 13,5	
	Unités par container 20' / 40'	9 / 19	9 / 19	9 / 19	9 / 19	6 / 12	6 / 12	
ALT	Code alternateur	18798	18803	18802	14229	1134	642	ALT
	Modèle	LSA 40 V52	LSA 40 S4	LSA 40 L7	LSA 42.2 L9	LSA 43.2 S15	LSA 43.2 M45	
	Fabricant	LEROY SOMER	LEROY SOMER	LEROY SOMER	LEROY SOMER	LEROY SOMER	LEROY SOMER	
	Système de regulation	AVR	AVR	AVR	AVR	AVR	AVR	
	Alternateur IP protection	IP23	IP23	IP23	IP23	IP23	IP23	
MOTEUR	Code moteur	12531	12536	12535	18476	DEU-0020	DEU-0021	MOTEUR
	Modèle	LPW2/8	LPW3/8	LPW4/8	D2009L04 /8	F4M2011/8	BF4M2011/8	
	Fabricant	LISTER	LISTER	LISTER	DEUTZ	DEUTZ	DEUTZ	
	Couplage	SAE5 7½	SAE5 7½	SAE5 7½	SAE5 7½	SAE3 11½	SAE3 11½	
	Refrigidissement / N° cylindres / Aspiration	Eau/2/Naturelle	Eau/3/Naturelle	Eau/4/Naturelle	Eau/4/Turbo	Huile/4/Naturelle	Huile/4/Turbo	
RC	<i>Manuel / À distance - RC</i>	G5 CALW M9C1 RC	G5 CALW M13C1 RC	G5 CALW M16C1 RC	G5 CADW M21C1 RC	G5 CADO M31C2 RC	G5 CADO M42C2 RC	RC
	Code groupe électrogène	18945	18947	18949	18951	18953	18955	
	Prix public	5.333 €	6.080 €	6.929 €	8.323 €	9.800 €	10.995 €	
Prix public	Poids net / Poids avec emballage [kg]	498 / 507	7570	619 / 628	715 / 730	1000 / 1015	975 / 985	Prix public
	Coffret type	Manuel-Distance	Manuel-Distance	Manuel-Distance	Manuel-Distance	Manuel-Distance	Manuel-Distance	
	Carté électronique	GPM3	GPM3	GPM3	GPM3	GPM3	GPM3	
RC	Coffret de contrôle / Cableage de contrôle	16169/129	16169/129	16169/129	16169/18526	16169/226	18454/226	RC
	Coffret de force / Cableage de force	2652/908	2545/544	2668/544	2 / 544	2641/440	11878/440	
A	<i>Automatique AMF panel - A</i>	G5 CALW M9C1 A	G5 CALW M13C1 A	G5 CALW M16C1 A	G5 CADW M21C1 A	G5 CADO M31C2 A	G5 CADO M42C2 A	A
	Code groupe électrogène	18946	18948	18950	18952	18954	18956	
	Prix public	5.493 €	6.156 €	6.987 €	8.364 €	9.855 €	11.095 €	
Prix public	Poids net / Poids avec emballage [kg]	498 / 507	564 / 573	619 / 628	720 / 735	925 / 935	975 / 985	Prix public
	Coffret type	Automatique AMF	Automatique AMF	Automatique AMF	Automatique AMF	Automatique AMF	Automatique AMF	
	Carté électronique	GECO MD	GECO MD	GECO MD	GECO MD	GECO MD	GECO MD	
AUTO	Coffret de contrôle / Cableage de contrôle	14840 / 129	14840/129	14840/129	14840 / 18526	14840/226	14840/226	AUTO
	Coffret de force / Cableage de force	2656/908	2581/544	2676/544	797 / 544	2642/440	11879/440	
KITS	Kit maint 1000 h MOTEUR	2276 / 108€	2278 / 116€	2278 / 116€	Consulter	DEU-1090 / 116€	DEU-1090 / 116€	KITS
	Kit maint/secours 1000 h MOTEUR	2277 / 143€	2279 / 143€	2279 / 143€	Consulter	DEU-1098 / 133€	DEU-1101 / 133€	
Options	<i>Options disponible (Code / Prix public)</i>							Options
ALT	AVR: NSM AVR alternator	SERIE	SERIE	SERIE	SERIE	SERIE	SERIE	ALT
	LSA: Leroy Somer alternator	SERIE	SERIE	SERIE	SERIE	SERIE	SERIE	
	LSA-TR: Leroy Somer tropicalized	XXXX / 271€	XXXX / 271€	XXXXXX / 271€	XXXXXX / 271€	14176 / 271€	12419 / 271€	
	LSA-PMG: Leroy Somer PMG system	Consult us	Consult us	Consult us	Consult us	Consult us	Consult us	
	LSACALD: Leroy Somer with preheating	XXXX / 203€	XXXX / 162€	XXXXXX / 162€	XXXXXX / 162€	15153 / 215€	15489 / 215€	
INS/ATS	1ATS: Integrated ATS for RC models	N.D.	N.D.	N.D.	N.D.	N.D.	N.D.	INS/ATS
	1ATS: Separated ATS for RC models	15925 / 170€	15926 / 294€	15926 / 294€	15926 / 294€	15926 / 294€	3262 / 477€	
	2ATS: Separated ATS for A models	15928 / 212€	15929 / 479€	15929 / 479€	15929 / 479€	15929 / 479€	3265 / 920€	
Coffret	TEMP: Automatic start/stop clock for RC	3017 / 131€	3017 / 131€	3017 / 131€	3017 / 131€	3017 / 131€	3017 / 131€	Coffret
	GPM2: G2M2 controller (A+V/A+F/V+F)	N.A.	N.A.	N.A.	N.A.	N.A.	N.A.	
	GPM3: GPM3 digital controller for RC models	SERIE	SERIE	SERIE	SERIE	SERIE	SERIE	
	GECO-MD: GECOMD digital for A models	SERIE	SERIE	SERIE	SERIE	SERIE	SERIE	
	AMF25: AMF25 digital for A with EMR	15023 / 161€	15023 / 161€	15023 / 161€	15023 / 161€	15343 / 161€	15343 / 161€	
	PROTDIF: Differential protection A models	15406 / 18€	15407 / 118€	15408 / 126€	15464 / 154€	15465 / 147€	15466 / 206€	
	BASES: Shokets for RC models	15147 / 118€	15147 / 118€	15147 / 118€	N.A.	N.A.	N.A.	
	DESCBAT: Battery disconnecter	15345 / 88€	15345 / 88€	15345 / 88€	15345 / 88€	15345 / 88€	15345 / 88€	
	VDO: Press & Temp transmitt. (GPM3/AMF25)	15965 / 88€	15965 / 88€	15965 / 88€	18803 / 250€	15967 / 130€	15967 / 130€	
	EMR-A: Engine electronic governor for A	N.D.	N.D.	N.D.	N.D.	15209 / 810€	14892 / 810€	
EMR-RC: Engine electronic governor for RC	N.D.	N.D.	N.D.	N.D.	15209 / 810€	14892 / 810€		
EMR-BUS: Engine MODBUS (needs AMF25)	N.D.	N.D.	N.D.	N.D.	15349 / 315€	15349 / 315€		
Moteur	AIRCALD: Air pre-heating for RC models	19156 / 70€	19156 / 70€	19156 / 70€	N.D.	19157 / 145€	SERIE	Moteur
	AIRCALD: Air pre-heating for A models	19158 / 75€	19158 / 75€	19158 / 75€	N.D.	19159 / 150€	SERIE	
	OILCALD: Oil pre-heating	N.D.	N.D.	N.D.	N.D.	N.D.	N.D.	
	LIQCALD: Liquid pre-heating	13086 / 482€	13086 / 482€	13086 / 482€	13081 / 411€	N.D.	N.D.	
	RESID: Residential muffler	SERIE	SERIE	SERIE	SERIE	SERIE	SERIE	
Inst	2,5FLEX50 (LISTER) / Ø60 (DEUTZ)	...934-032/55€	...934-032/55€	...934-032/55€	...934-032/55€	12874 / 57€	12874 / 57€	Inst
	5FLEX50 (LISTER) / Ø60 (DEUTZ)	...934-033/93€	...934-033/93€	...934-033/93€	...934-033/93€	12875 / 98€	12875 / 98€	
	C1/C2 (Soundproofing option price)	1.800 €	1.800 €	1.800 €	1.800 €	2.200 €	2.200 €	
Chariot	C.OBRA: Not aproved trailer	1Axle / Ball Consult us	1Axle / Ball Consult us	1Axle / Ball Consult us	1Axle / Ball Consult us	1Axle / Ball Consult us	1Axle / Ball Consult us	Chariot
	C.HOMOL: Aproved trailer (In Spain)	N.D.	N.D.	N.D.	N.D.	N.D.	N.D.	
	C.ART: Articulated rod	Consult us	Consult us	Consult us	Consult us	Consult us	Consult us	
Comb	C.ARG: O-hitch ring or ballmount coupling	SERIE	SERIE	SERIE	SERIE	SERIE	SERIE	Comb
	RETEN: 110% liquid retention tray	SERIE	SERIE	SERIE	SERIE	SERIE	SERIE	
	B.SOLD: Internally welded retention tray	SERIE	SERIE	SERIE	SERIE	SERIE	SERIE	
	DECCOMB: Fuel decanter	SERIE	SERIE	SERIE	SERIE	SERIE	SERIE	
	190L (C1) 250L (C2): Extra large fuel tanks	13493 / 273€	13493 / 273€	13493 / 273€	13493 / 273€	18158 / 350€	18158 / 350€	
B-TR-MN: Semi-Automatic fuel electropump	15432 / 500€	15432 / 500€	15432 / 500€	15432 / 500€	3046 / 500€	3046 / 500€		
B-TR-AU: Automatic fuel electropump	15433 / 542€	15433 / 542€	15433 / 542€	15433 / 542€	12488 / 542€	12488 / 542€		



Groupes ouverts (Possibility of soundproofing) = TRIPHASE 1500 tr/mn

G5	GROUPES ÉLECTROGÈNES 50HZ					
C	CONTINU 1500rpm 24h/dia --- 2000h/año			A Open with possibility of soundproofing		
L/D	MOTEUR			SYSTÈME DE REFROIDISSEMENT		
	L	Lister-Petter		W/O	W	EAU
	D	Deutz			A	AIR
			O		HUILLE	
RC	Manuel - À distance			A Automatique AMF panel		

50 HERTZ

1500 RPM

KVA	Données techniques	CADO M55	CALW T10	CALW T15	CALW T20	CADW T25	CADO T35	KVA
TECHNIQUES	Normé d'émissions 2002/88	OUI	Exempt	Exempt	Exempt	OUI	OUI	TECHNIQUES
	Normé acoustique 2000/14/CE	NON	OUI	OUI	OUI	OUI	NON	
	Secours / Continue [kVA]	55 / 50	10 / 9	14 / 12,5	19,5 / 17,5	25 / 23	35 / 31,5	
	Voltage [V] / Intensité [A] / Cos φ	230/239/0,9	400 / 14 / 0,8	400 / 21 / 0,8	400 / 28 / 0,8	400 / 36 / 0,8	400 / 50 / 0,8	
	Dimensions longueur x largeur x hauteur [mm]	2250/950/1250	1800/740/1170	1800/740/1170	1800/740/1170	1800/740/1170	2250/950/1250	
	Dim emballage long x largeur x hauteur [mm]	2300/1000/1250	1800/750/1170	1800/750/1170	1800/750/1170	1800/750/1170	2300/1000/1250	
	Puissance acoustique LWA [dBA]	99	96	96	97	96	99	
	Pression acoustique LPA [dBA]16m/10m/7m/4m	67/71/74/79	64/68/71/76	64/68/71/76	65/69/72/77	64/68/71/76	67/71/74/79	
	Réservoir [l] / Autonomie 75% (PRP) [h]	100 / 12,5	50 / 33	50 / 23	50 / 17	50 / 12,5	100 / 17	
	Unités par container 20' / 40'	6 / 12	9 / 19	9 / 19	9 / 19	9 / 19	5 / 10	
ALT	Code alternateur	207	18805	18798	18803	18802	1151	ALT
	Modèle	LSA 43.2 L8	LSA 40 VS1	LSA 40 VS2	LSA 40 S4	LSA 40 L7	LSA 42.2 L9	
	Fabricant	LEROY SOMER	LEROY SOMER	LEROY SOMER	LEROY SOMER	LEROY SOMER	LEROY SOMER	
	Système de regulation	AVR	AVR	AVR	AVR	AVR	AVR	
	Alternateur IP protection	IP23	IP23	IP23	IP23	IP23	IP23	
MOTEUR	Code moteur	18150	12531	12536	12535	18476	DEU-0020	MOTEUR
	Modèle	BF4M2011C	LPW2	LPW3	LPW4	D2009L04	F4M2011	
	Fabricant	DEUTZ	LISTER	LISTER	LISTER	DEUTZ	DEUTZ	
	Couplage	SAE3 11½	SAE5 7½	SAE5 7½	SAE5 7½	SAE5 7½	SAE3 11½	
	Refroidissement / N° cylindres / Aspiration	Huile/4/Turbo	Eau/2/Naturelle	Eau/3/Naturelle	Eau/4/Naturelle	Eau/4/Turbo	Huile/4/Naturelle	
RC	Manuel / À distance - RC	G5 CADO M55C2 RC	G5 CALW T10C1 RC	G5 CALW T15C1 RC	G5 CALW T20C1 RC	G5 CADW T25C1 RC	G5 CADO T35C2 RC	RC
	Code groupe électrogène	19008	18957	18959	18961	18963	18965	
	Prix public	13.485 €	5.219 €	5.850 €	6.740 €	7.895 €	9.495 €	
Prix public	Poids net / Poids avec emballage [kg]	1020 / 1040	500 / 510	550 / 560	650 / 665	690 / 700	1000 / 1015	Prix public
	Coffret type	Manuel-Distance	Manuel-Distance	Manuel-Distance	Manuel-Distance	Manuel-Distance	Manuel-Distance	
	Carté électronique	6PM3	6PM3	6PM3	6PM3	6PM3	6PM3	
RC	Coffret de contrôle / Cableage de contrôle	18454/226	16169/129	16169/129	16169/129	16169 / 18526	16778/226	RC
	Coffret de force / Cableage de force	11880/440	16214/1711	3245/1711	1723/1711	1723 / 1711	1665/1668	
	Code groupe électrogène	19009	18958	18960	18962	18964	18966	
A	Automatique AMF panel - A	G5 CADO M55C2 A	G5 CALW T10C1 A	G5 CALW T15C1 A	G5 CALW T20C1 A	G5 CADW T25C1 A	G5 CADO T35C2 A	A
	Code groupe électrogène	19009	18958	18960	18962	18964	18966	
	Prix public	13.350 €	5.399 €	5.990 €	6.890 €	8.095 €	9.581 €	
Prix public	Poids net / Poids avec emballage [kg]	1020 / 1040	500 / 510	550 / 560	650 / 665	690 / 700	1000 / 1015	Prix public
	Coffret type	Automatique AMF	Automatique AMF	Automatique AMF	Automatique AMF	Automatique AMF	Automatique AMF	
	Carté électronique	GECO MD	GECO MD	GECO MD	GECO MD	GECO MD	GECO MD	
AUTO	Coffret de contrôle / Cableage de contrôle	14840/226	14840/129	14840/129	14840/129	14840 / 18526	14840/226	AUTO
	Coffret de force / Cableage de force	11881/440	16214/1711	3245/1711	1723/1711	1723 / 1711	1680/1668	
	Code groupe électrogène	19009	18958	18960	18962	18964	18966	
KITS	Kit maint 1000 h MOTEUR	Consulter	2276 / 108€	2278 / 116€	2278 / 116€	Consulter	DEU-1090/ 116€	KITS
	Kit maint/secours 1000 h MOTEUR	Consulter	2277 / 143€	2279 / 143€	2279 / 143€	Consulter	DEU-1098/ 133€	
Options	<i>Options disponibles (Code / Prix public)</i>							Options
ALT	LSA: Leroy Somer alternator	SERIE	SERIE	SERIE	SERIE	SERIE	SERIE	ALT
	LSA-TR: Leroy Somer tropicalized	12419 / 271€	XXXXX / 271€	XXXXX / 271€	XXXXX / 271€	XXXXX / 271€	14175 / 271€	
	LSA-PMG: Leroy Somer PMG system	Consulter	Consulter	Consulter	Consulter	Consulter	Consulter	
	LSACALD: Leroy Somer with preheating	15489 / 215€	XXXXX / 203€	XXXXX / 203€	XXXXX / 203€	XXXXX / 162€	14251 / 162€	
INS/ATS	1ATS: Integrated ATS for RC models	N.D.	N.D.	N.D.	N.D.	N.D.	N.D.	INS/ATS
	1ATS: Separated ATS for RC models	3262 / 477€	1976 / 170€	1976 / 170€	1976 / 170€	1976 / 170€	1989 / 294€	
	2ATS: Separated ATS for A models	3265 / 920€	1977 / 212€	1977 / 212€	1977 / 212€	1977 / 212€	1999 / 479€	
	TEMP: Automatic start/stop clock for RC	3017 / 131€	3017 / 131€	3017 / 131€	3017 / 131€	3017 / 131€	3017 / 131€	
Coffret	220V: Output voltage 220V for RC models	N.D.	15400 / 20€	15393 / 58€	15395 / 54€	15383 / 74€	15398 / 280€	Coffret
	220V: Output voltage 220V for A models	N.D.	15401 / 16€	15394 / 42€	15396 / 58€	15386 / 102€	15399 / 102€	
	GPM2: G2M2 controller (A+V/A+F/V+F)	N.D.	N.D.	N.D.	N.D.	N.D.	N.D.	
	GPM3: GPM3 digital controller for RC models	SERIE	SERIE	SERIE	SERIE	SERIE	SERIE	
	GECO-MD: GECOMD digital for A models	SERIE	SERIE	SERIE	SERIE	SERIE	SERIE	
	AMF25: AMF25 digital for A with EMR	15023 / 161€	15023 / 161€	15023 / 161€	15023 / 161€	15343 / 161€	15343 / 161€	
	PROTDIF: Differential protection A models	N.D.	15437 / 76€	15438 / 73€	15439 / 80€	15467 / 121€	15468 / 119€	
	BASES: Shokets for RC models	N.D.	15145 / 118€	15145 / 118€	15145 / 118€	16014 / 200€	16015 / 200€	
	DESCBAT: Battery disconnecter	15345 / 88€	15345 / 88€	15345 / 88€	15345 / 88€	15345 / 88€	15345 / 88€	
	VDO: Press & Temp transmitt. (GPM3/AMF25)	15967 / 130€	15965 / 88€	15965 / 88€	15965 / 88€	18803 / 250€	15967 / 130€	
	EMR-A: Engine electronic governor for A	15209 / 810€	N.D.	N.D.	N.D.	N.D.	15209 / 810€	
	EMR-RC: Engine electronic governor for RC	15209 / 810€	N.D.	N.D.	N.D.	N.D.	15209 / 810€	
EMR-BUS: Engine MODBUS (needs AMF25)	15349 / 325€	15349 / 325€	15349 / 325€	15349 / 325€	N.D.	15349 / 325€		
Moteur	AIRCALD: Air pre-heating for RC models	SERIE	19156 / 70€	19156 / 70€	19156 / 70€	N.D.	19157 / 145€	Moteur
	AIRCALD: Air pre-heating for A models	SERIE	19158 / 75€	19158 / 75€	19158 / 75€	N.D.	19159 / 150€	
	LIQCALD: Liquid pre-heating	N.D.	13086 / 482€	13086 / 482€	13086 / 482€	13081 / 411€	N.D.	
	RESTD: Residential muffler	SERIE	SERIE	SERIE	SERIE	SERIE	SERIE	
Inst	2.5FLEX50 (LISTER) / Ø60 (DEUTZ)	12874 / 57€	...934-032/ 55€	...934-032/ 55€	...934-032/ 55€	...934-032/ 55€	12874 / 57€	Inst
	5FLEX50 (LISTER) / Ø60 (DEUTZ)	12875 / 98€	...934-033/ 92€	...934-033/ 92€	...934-033/ 92€	...934-033/ 92€	12875 / 98€	
	C1/C2 (Soundproofing option price)	2.200 €	1.800 €	1.800 €	1.800 €	1.800 €	2.200 €	
Chariot	C.OBRA: Not aproved trailer	1 Axle / Ball 956/ 1056€	1Axle / Ball 15518 / 920€	1Axle / Ball 15518 / 920€	1Axle / Ball 15518 / 920€	1Axle / Ball 15518 / 920€	1 Axle / Ball 956/ 1056€	Chariot
	C.HOMOL: Aproved trailer	N.A.	N.D.	N.D.	N.D.	N.D.	N.D.	
Comb	RETEN: 110% liquid retention tray	SERIE	SERIE	SERIE	SERIE	SERIE	SERIE	Comb
	B.SOLD: Internally welded retention tray	SERIE	SERIE	SERIE	SERIE	SERIE	SERIE	
	DECCOMB: Fuel decanter	15970 / 361€	SERIE	SERIE	SERIE	SERIE	15970 / 361€	
	190L (C1) 250L (C2): Extra large fuel tanks	18158 / 350€	13493 / 273€	13493 / 273€	13493 / 273€	13493 / 273€	18158 / 350€	
	B-TR-MN: Semi-Automatic fuel electropump	3046 / 500€	15432 / 500€	15432 / 500€	15432 / 500€	15432 / 500€	3046 / 500€	
B-TR-AU: Automatic fuel electropump	12488 / 542€	15433 / 542€	15433 / 542€	15433 / 542€	15433 / 542€	12488 / 542€		



Foto: Con opción de carrocería

Groupes ouverts (Possibility of soundproofing) = TRIPHASE 1500 tr/mn

G5	GROUPES ÉLECTROGÈNES 50HZ				
C	CONTINU 1500rpm 24h/dia --- 2000h/año		A	Open with possibility of soundproofing	
L/D	MOTEUR		W/O	SYSTÈME DE REFRIGÉRISSMENT	
	L	Lister-Petter		W	EAU
	D	Deutz		A	AIR
RC	Manuel - À distance		A	Automatique AMF panel	
				O	HUILE

50
HERTZ

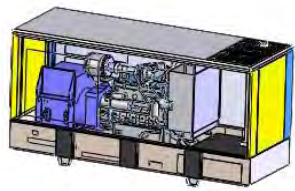
1500
RPM

KVA	Données techniques	CADO T47	CADO T65	CADW T100	CADW T115	CADW T140	KVA
TECHNIQUES	Normé d'émissions 2002/88	OUI	OUI	NON	OUI	OUI	DONNEES TECHNIQUES
	Normé acoustique 2000/14/CE	OUI	OUI	NON	NON	NON	
	Secours / Continue [kVA]	47 / 42	65 / 58	100 / 90	115 / 104	140 / 125	
	Voltage [V] / Intensité [A] / Cos φ	400 / 67 / 0,8	400 / 93 / 0,8	400 / 145 / 0,8	400 / 166 / 0,8	400 / 200 / 0,8	
	Dimensions longueur x largeur x hauteur [mm]	2250/950/1250	2250/950/1250	3000/1100/1480	3000/1100/1480	3000/1100/1480	
	Dim emballage long x largeur x hauteur [mm]	2300/1000/1250	2300/1000/1250	3050/1130/1480	3050/1130/1480	3050/1130/1480	
	Puissance acoustique LWA [dBA]	97	97	99	101	103	
	Pression acoustique LPA [dBA]16m/10m/7m/4m	65/69/72/77	65/69/72/77	67/71/74/79	69/73/76/81	71/75/78/83	
	Réservoir [l] / Autonomie 75% (PRP) [h]	80 / 11	100 / 9,5	150 / 10	150 / 8	150 / 6	
	Unités par container 20' / 40'	5 / 10	6 / 12	2 / 6	2 / 6	2 / 6	
ALT	Code alternateur	1134	642	392	392	639	ALT
	Modèle	LSA43.2S15	LSA43.2M45	LSA44.2VS45	LSA44.2VS45	LSA44.2S75	
	Fabricant	LEROY SOMER	LEROY SOMER	LEROY SOMER	LEROY SOMER	LEROY SOMER	
	Système de regulation	AVR	AVR	AVR	AVR	AVR	
	Alternateur IP protection	IP23	IP23	IP23	IP23	IP23	
MOTEUR	Code moteur	DEU-0021	18150	999	714	2852	MOTEUR
	Modèle	BF4M2011	BF4M2011C	BF4M1013E	BF4M1013EC	BF4M1013FC	
	Fabricant	DEUTZ	DEUTZ	DEUTZ	DEUTZ	DEUTZ	
	Couplage	SAE3 11½	SAE3 11½	SAE2 11½	SAE2 11½	SAE2 11½	
	Refrégerissement / N° cylindres / Aspiration	Huile/4/Turbo	Huile/4/Turbo	Eau/4/Turbo	Eau/4/Turbo	Eau/6/Turbo	
RC	Manuel / À distance - RC	G5 CADO T47C2 RC	G5 CADO T65C2 RC	G5 CADW T100C3 RC	G5 CADW T115C3 RC	G5 CADW T140C3 RC	RC
	Code groupe électrogène	18967	18969	18971	18973	18975	
	Prix public	10.450 €	11.980 €	sept-2010	sept-2010	sept-2010	
RC	Coffret type	Manuel-Distance	Manuel-Distance	Manuel-Distance	Manuel-Distance	Manuel-Distance	RC
	Carté électronique	GPM3	GPM3	GPM3	GPM3	GPM3	
	Coffret de contrôle / Cableage de contrôle	14854/226	14854/226	16778/646	16777/646	16779/18472	
A	Automatique AMF panel - A	G5 CADO T47C2 A	G5 CADO T65C2 A	G5 CADW T100C3 A	G5 CADW T115C3 A	G5 CADW T140C3 A	A
	Code groupe électrogène	18968	18970	18972	18974	18976	
	Prix public	10.590 €	11.950 €	sept-2010	sept-2010	sept-2010	
AUTO	Automatique AMF	Automatique AMF	Automatique AMF	Automatique AMF	Automatique AMF	Automatique AMF	AUTO
	Code groupe électrogène	GECO MD	GECO MD	GECO MD	GECO MD	GECO MD	
	Coffret de contrôle / Cableage de contrôle	14840/226	14840 / 226	16781/646	16782/646	16783/18472	
KITS	Kit maint 1000 h MOTEUR	DEU-1090/116€	DEU-1090/116€	DEU-1114/161€	DEU-1114/ 161€	Consulter	KITS
	Kit maint/secours 1000 h MOTEUR	DEU-1101/135€	DEU-1101 / 135€	DEU-1115/272€	DEU-1115/ 272€	Consulter	
Options	Options DISPONIBLES (Code / Prix public)					Options	
ALT	LSA: Leroy Somer alternator	SERIE	SERIE	SERIE	SERIE	SERIE	ALT
	LSA-TR: Leroy Somer tropicalized	14176 / 271€	12419 / 271€	15309 / 280€	15309 / 280€	15310 / 280€	
	LSA-PMG: Leroy Somer PMG system	Consulter	Consulter	Consulter	Consulter	Consulter	
	LSACALD: Leroy Somer with preheating	15153 / 215€	15489 / 215€	15155 / 215€	15155 / 215€	15491 / 215€	
INS/ATS	1ATS: Integrated ATS for RC models	N.D.	N.D.	N.D.	N.D.	N.D.	INS/ATS
	1ATS: Separated ATS for RC models	1989 / 294€	1989 / 294€	3262 / 477€	3262 / 477€	3262 / 477€	
	2ATS: Separated ATS for A models	1999 / 479€	1999 / 479€	3265 / 920€	3265 / 920€	3265 / 920€	
	TEMP: Automatic start/stop clock for RC	3017 / 131€	3017 / 131€	3017 / 131€	3017 / 131€	3017 / 131€	
Coffret	220V: Output voltage 220V for RC models	15391 / 279€	15454 / 409€	15480 / 608€	15482 / 826€	15484 / 533€	Coffret
	220V: Output voltage 220V for A models	15392 / 102€	15455 / 375€	15481 / 571€	15483 / 848€	15485 / 547€	
	GPM2: GM2 controller (A+V/A+V/F+F)	N.D.	N.D.	N.D.	N.D.	N.D.	
	GPM3: GPM3 digital controller for RC models	SERIE	SERIE	SERIE	SERIE	SERIE	
	GECO-MD: GECOMD digital for A models	SERIE	SERIE	SERIE	SERIE	SERIE	
	AMF25: AMF25 digital for A with EMR	15343 / 161€	15023 / 161€	15343 / 161€	15343 / 161€	15343 / 161€	
	PROTDIF: Differential protection A models	15469 / 119€	15443 / 170€	15471 / 147€	15472 / 193€	15473 / 179€	
	BASES: Shokets for RC models	16016 / 300€	Consulter	18052 / 412€	18052 / 412€	18052 / 412€	
	DESCBAT: Battery disconnecter	15345 / 88€	15345 / 88€	15345 / 88€	15345 / 88€	15345 / 88€	
	VDO: Press & Temp transmitt. (GPM3/AMF25)	15967 / 130€	15967 / 130€	15968 / 140€	15968 / 140€	15968 / 140€	
Moteur	EMR-A: Engine electronic governor for A	14892 / 810€	XXXX / 810€	15217/1107€	15218/1107€	SERIE	Moteur
	EMR-RC: Engine electronic governor for RC	14892 / 810€	XXXX / 810€	15217/1107€	15218/1107€	SERIE	
	EMR-BUS: Engine MODBUS (needs AMF25)	15349 / 325€	15349 / 325€	15349 / 325€	15349 / 325€	15349 / 325€	
	AIRCALD: Air pre-heating for RC models	SERIE	SERIE	N.D.	N.D.	N.D.	
	AIRCALD: Air pre-heating for A models	SERIE	SERIE	N.D.	N.D.	N.D.	
Inst	LIQCALD: Liquid pre-heating	N.D.	N.D.	13081 / 411€	13081 / 411€	13081 / 411€	Inst
	RESID: Residential muffler	SERIE	SERIE	SERIE	SERIE	SERIE	
	2,5FLEX60 (T35-T47) / Ø100 (T70-T150)	12874 / 57€	12874 / 57€	15324 / 85€	15324 / 85€	15324 / 85€	
	5FLEX60 (T35-T47) / Ø100 (T70-T150)	12875 / 98€	12875 / 98€	15325 / 162€	15325 / 162€	15325 / 162€	
Chariot	C2/C3 (Soundproofing option price)	2.200 €	2.200 €	sep-10	sep-10	sep-10	Chariot
	C.OBRA: Not aproved trailer	1 Axle / Ball 956/1056€	1 Axle / Ball CONSULTAR	2 Axles / ARG 1339/1211€	2 Axles / ARG 1339/1211€	2 Axles / ARG 1339/1211€	
	C.HOMOL: Aproved trailer (In Spain)	N.D.	N.D.	N.D.	N.D.	N.D.	
	C.ART: Articulated rod	Consulter	Consulter	Consulter	Consulter	Consulter	
	C.ARG: O-hitch ring or ballmount coupling	Consulter	Consulter	Consulter	Consulter	Consulter	
Comb	B.RETEN: 110% liquids retention tray	SERIE	SERIE	SERIE	SERIE	SERIE	Comb
	B.SOLD: Internally welded retention tray	SERIE	SERIE	SERIE	SERIE	SERIE	
	DECCOMB: Fuel decanter	15970 / 361€	15970 / 361€	SERIE	SERIE	SERIE	
	250L (C2) : Extra large fuel tanks	18158 / 350€	18158 / 350€	Consulter	Consulter	Consulter	
	B-TR-MN: Semi-Automatic fuel electropump	3046 / 500€	3046 / 500€	3046 / 500€	3046 / 500€	3046 / 500€	
B-TR-AU: Automatic fuel electropump	12488 / 542€	12488 / 542€	12488 / 542€	12488 / 542€	12488 / 542€		

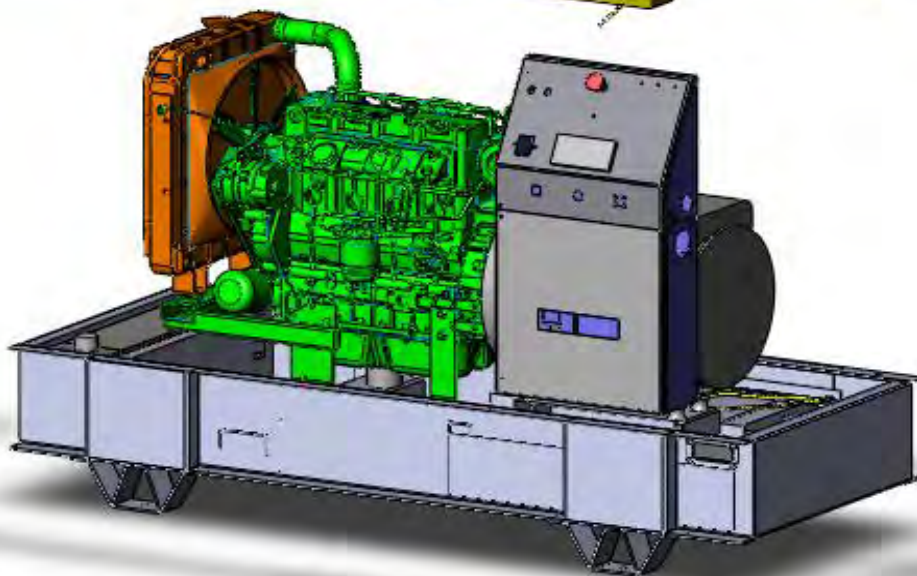
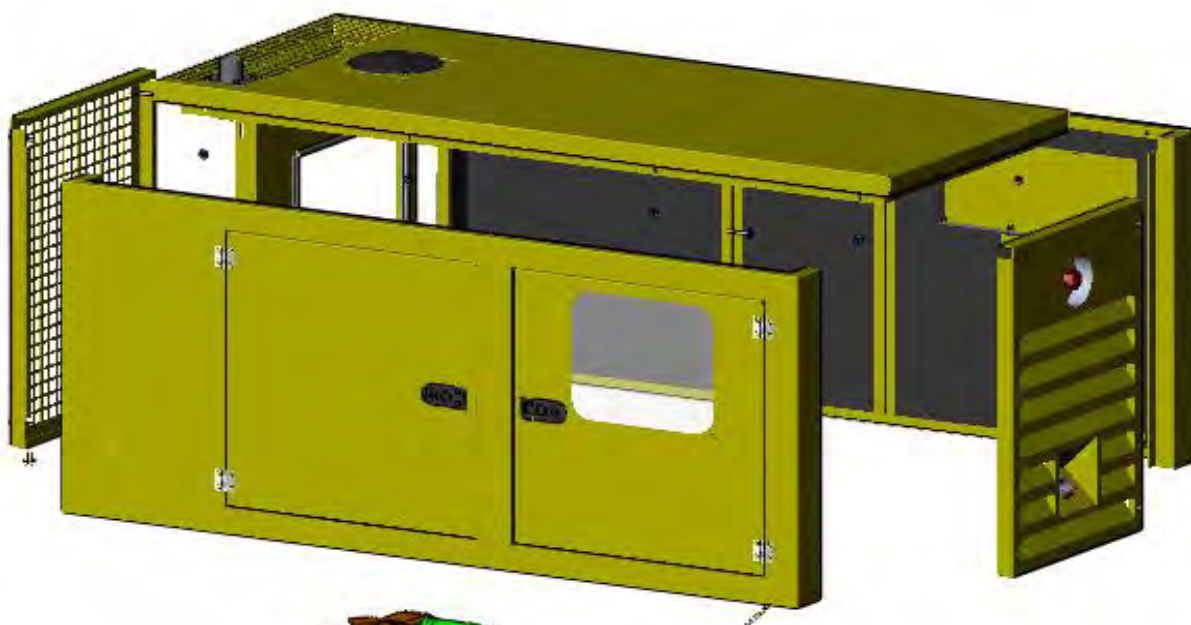
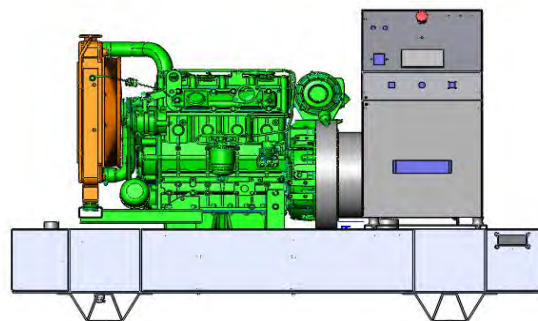

Groupes ouverts(Possibility of soundproofing) - 1500tr/mn - 24h/jour - 2000h/an

Groupes insonorisés - 1500tr/mn - 24h/jour - 2000h/an



Groupes insonorisés - 1500tr/mn - 24h/jour - 2000h/an



GRUPOS ÉLECTROGÉNES INSONORISÉS = MONOPHASE 1500tr/mm

50 HERTZ

1500 RPM

G5	Tarif GRUPOS 50HZ					
C	CONTINU 1500rpm 24h/day --- 2000h/year <i>MOTEUR</i>			INSONORISE		
L/D	L	Lister-Petter		W/O	Système de REFROIDISSEMENT W Air Eau A Air O Huile	
RC	Manuel - À distance			A	Automatique AMF panel	

KVA	Données techniques	M9 C1	M13 C1	M16 C1	M21 C1	M31	M42	KVA
DONNEES TECHNIQUES	Norme d'émissions 2002/88	Exempt	Exempt	Exempt	OUI	OUI	OUI	DONNEES TECHNIQUES
	Norme acoustique 2000/14/CE	OUI	OUI	OUI	OUI	OUI	OUI	
	Secours / Continue [kVA]	9 / 8	13 / 11	16 / 14	20,6 / 18	30,5 / 28	42 / 38	
	Voltage [V] / Intensité [A] / Cos φ	230/39/0,9	230/56/0,9	230/69/0,9	230/91/0,9	230/132/0,9	230/180/0,9	
	Dimensions longueur x largeur x hauteur [mm]	1800/740/1170	1800/740/1170	1800/740/1170	1800/740/1170	2200/1000/1260	2200/1000/1260	
	Dim emballage long x largeur x hauteur [mm]	1800/750/1170	1800/750/1170	1800/750/1170	1800/750/1170	2230/1080/1260	2230/1080/1260	
	Puissance acoustique LWA [dBA]	87	87	89	86	94	94	
	Pression acoustique LPA [dBA] 16m/10m/7m/4m	55/59/62/67	55/59/62/67	57/61/64/69	54/58/61/66	62/66/69/74	62/66/69/74	
	Réservoir [l] / Autonomie 75% (PRP) [h]	50 / 33	50 / 23	50 / 17	50 / 12,5	80 / 14	80 / 11	
	Unités par container 20' / 40'	9 / 19	9 / 19	9 / 19	9 / 19	5 / 10	5 / 10	
ALT	Code alternateur	18798	18803	18802	14229	1134	642	ALT
	Modèle	LSA 40 VS2	LSA 40 S4	LSA 40 L7	LSA 42.2 L9	LSA 43.2 S15	LSA 43.2 M45	
	Fabricant	LEROY SOMER	LEROY SOMER	LEROY SOMER	LEROY SOMER	LEROY SOMER	LEROY SOMER	
	Système de regulation	AVR	AVR	AVR	AVR	AVR	AVR	
MOTEUR	Code moteur	12531	12536	12535	18476	DEU-0020	DEU-0021	MOTEUR
	Modèle	LPW2	LPW3	LPW4	D2009L04	F4M2011	BF4M2011	
	Fabricant	LISTER	LISTER	LISTER	DEUTZ	DEUTZ	DEUTZ	
	Couplage	SAE5 7½	SAE5 7½	SAE5 7½	SAE5 7½	SAE3 11½	SAE3 11½	
	Refroidissement / N° cylindres / Aspiration	Eau/2/Naturelle	Eau/3/Naturelle	Eau/4/Naturelle	Eau/4/Turbo	Huile/4/Naturelle	Huile/4/Turbo	
RC	Manuel / À distance - RC	G5 CILW	G5 CILW	G5 CILW	G5 CIDW	G5 CIDO	G5 CIDO	RC
	Code groupe électrogène	M9C1 RC	M13C1 RC	M16C1 RC	M21C1 RC	M31 RC	M42 RC	
	Prix public	2596	2563	2629	18816	GED0597	15346	
	Poids net / Poids avec emballage [kg]	498 / 507	7570	619 / 628	715 / 730	925 / 935	975 / 985	
RC	Coffret type	Manuel-Distance	Manuel-Distance	Manuel-Distance	Manuel-Distance	Manuel-Distance	Manuel-Distance	RC
	Carté électronique	GPM3	GPM3	GPM3	GPM3	GPM3	GPM3	
	Coffret de contrôle / Cableage de contrôle	16169/129	16169/129	16169/129	16169/18526	16777/226	16777/226	
	Coffret de force / Cableage de force	2652/908	2545/890	2668/890	2 / 544	1633/440	16433/440	
A	Automatique AMF panel - A	G5 CILW	G5 CILW	G5 CILW	G5 CIDW	G5 CIDO	G5 CIDO	A
	Code groupe électrogène	M9C1 A	M13C1 A	M16C1 A	M21C1 A	M31 A	M42 A	
	Prix public	2675	2626	2629	18815	836	15347	
	Poids net / Poids avec emballage [kg]	498 / 507	564 / 573	619 / 628	720 / 735	925 / 935	975 / 985	
AUTO	Coffret type	Automatique AMF	Automatique AMF	Automatique AMF	Automatique AMF	Automatique AMF	Automatique AMF	AUTO
	Carté électronique	GECO MD	GECO MD	GECO MD	GECO MD	GECO MD	GECO MD	
	Coffret de contrôle / Cableage de contrôle	14840 / 129	14840/129	14840/129	14840 / 18526	16782/226	16782/226	
	Coffret de force / Cableage de force	2656/908	2581/890	2676/890	797 / 544	12902/440	16432/440	
KITS	Kit maint 1000 h MOTEUR	2276 / 108€	2278 / 116€	2278 / 116€	Consulter	DEU-1090 /116€	DEU-1090 /116€	KITS
	Kit maint/secours 1000 h MOTEUR	2277 / 143€	2279 / 143€	2279 / 143€	Consulter	DEU-1098 /133€	DEU-1101 / 133€	
Options	Options disponibles (Code / Prix public)						Options	
ALT	LSA: Leroy Somer alternator	SERIE	SERIE	SERIE	SERIE	SERIE	SERIE	ALT
	LSA-TR: Leroy Somer tropicalized	XXXX / 271€	XXXX / 271€	XXXXX / 271€	XXXXX / 271€	14176 / 271€	12419 / 271€	
	LSA-PMG: Leroy Somer PMG system	Consulter	Consulter	Consulter	Consulter	Consulter	Consulter	
	LSACALD: Leroy Somer with preheating	XXXX / 203€	XXXX / 162€	XXXXX / 162€	XXXXX / 162€	15153 / 215€	15489 / 215€	
INS/ATS	1ATS: Integrated ATS for RC models	N.D.	N.D.	N.D.	N.D.	N.D.	N.D.	INS/ATS
	1ATS: Separated ATS for RC models	15925 / 170€	15926 / 294€	15926 / 294€	15926 / 294€	15926 / 294€	3262 / 477€	
	2ATS: Separated ATS for A models	15928 / 212€	15929 / 479€	15929 / 479€	15929 / 479€	15929 / 479€	3265 / 479€	
	TEMP: Automatic start/stop clock for RC	3017 / 131€	3017 / 131€	3017 / 131€	3017 / 131€	3017 / 131€	3017 / 131€	
Coffret	GPM2: GPM2 controller (A+V/A+F/V+F)	N.D.	N.D.	N.D.	N.D.	N.D.	N.D.	Coffret
	GPM3: GPM3 digital controller for RC models	SERIE	SERIE	SERIE	SERIE	SERIE	SERIE	
	GECO-MD: GECOMD digital for A models	SERIE	SERIE	SERIE	SERIE	SERIE	SERIE	
	AMF25: AMF25 digital for A with EMR	15023 / 161€	15023 / 161€	15023 / 161€	15023 / 161€	15343 / 161€	15343 / 161€	
	PROTDIF: Differential protection A models	15406 / 18€	15407 / 118€	15408 / 126€	15464 / 154€	15465 / 147€	15466 / 206€	
	BASES: Shokets for RC models	15147 / 118€	15147 / 118€	15147 / 118€	N.D.	N.D.	N.D.	
	DESCBAT: Battery disconnecter	15345 / 88€	15345 / 88€	15345 / 88€	15345 / 88€	15345 / 88€	15345 / 88€	
	VDO: Press & Temp transmitt. (GPM3/AMF25)	15965 / 88€	15965 / 88€	15965 / 88€	18803 / 250€	15967 / 130€	15967 / 130€	
Moteur	EMR-A: Engine electronic governor for A	N.D.	N.D.	N.D.	N.D.	15209 / 810€	14892 / 810€	Moteur
	EMR-RC: Engine electronic governor for RC	N.D.	N.D.	N.D.	N.D.	15209 / 810€	14892 / 810€	
	EMR-BUS: Engine MODBUS (needs AMF25)	N.D.	N.D.	N.D.	N.D.	15349 / 315€	15349 / 315€	
	AIRCALD: Air pre-heating for RC models	19156 / 70€	19156 / 70€	19156 / 70€	N.D.	19157 / 145€	SERIE	
	AIRCALD: Air pre-heating for A models	19158 / 75€	19158 / 75€	19158 / 75€	N.D.	19159 / 150€	SERIE	
Inst	LIQCALD: Liquid pre-heating	13086/482€	13086/482€	13086/482€	13081/411€	N.D.	N.D.	Inst
	RESID: Residential muffler	SERIE	SERIE	SERIE	SERIE	SERIE	SERIE	
	2_5FLEX50 (LISTER) / Ø60 (DEUTZ)	...934-032/55€	...934-032/55€	...934-032/55€	...934-032/55€	12874 / 57€	12874 / 57€	
	5FLEX50 (LISTER) / Ø60 (DEUTZ)	...934-033/93€	...934-033/93€	...934-033/93€	...934-033/93€	12875 / 98€	12875 / 98€	
Chariot	CAPOT: Open canopy (Consult us)	16935/-500€	16936/-500€	16938/-500€	16938/-500€	N.D.	N.D.	Chariot
	C.OBRA: Not aproved trailer	1Axle / Ball 15518 / 920€	1Axle / Ball 15518 / 920€	1Axle / Ball 15518 / 920€	1Axle / Ball 15518 / 920€	1Axle / Ball xxx/1056€	1Axle / Ball xxx/1056€	
	C.HOMOL: Aproved trailer (In Spain)	1Axle / Ball 15519 / 1700€	1Axle / Ball 15519 / 1700€	1Axle / Ball 15519 / 1700€	1Axle / Ball 15519 / 1700€	1Axle / Ball XXX/2289€	1Axle / Ball XXX/2289€	
	C.ART: Articulated rod	Consulter	Consulter	Consulter	Consulter	Consulter	Consulter	
	C.ARG: O-hitch or ballmounted coupling	SERIE	SERIE	SERIE	SERIE	Consulter	Consulter	
	B.RETEN: 110% liquids retention tray	SERIE	SERIE	SERIE	SERIE	12823 / 500€	12823 / 500€	
	B.SOLD: Internally welded retention tray	SERIE	SERIE	SERIE	SERIE	15692 / 124€	15692 / 124€	
	DECCOMB: Fuel decanter filter or pre-filter	SERIE	SERIE	SERIE	SERIE	15970 / 361€	15970 / 361€	
Comb	190L (C1): 250L (C2): 420L (M31-M42)	13493/273€	13493/273€	13493/273€	13493/273€	3175 / 522€	3175 / 522€	Comb
	B-TR-MN: Semi-Automatic fuel electropump	N.D.	N.D.	N.D.	N.D.	3046 / 500€	3046 / 500€	
	B-TR-AU: Automatic fuel electropump	N.D.	N.D.	N.D.	N.D.	12488 / 542€	12488 / 542€	

GRUPEES ELECTROGENES INSONORISEES = TRIPHASE 1500tr/mn



50
HERTZ

1500
RPM

G5	CONTINU		Tarif GRUPEES 50HZ	
C	1500rpm 24h/day --- 2000h/year		I	INSONORISE
L/D	L	Lister-Petter	W/O	Système de REFRIGERATION
	D	Deutz		W Eau A Air O Huile

RC	Manuel - À distance			A	Automatique AMF panel	
-----------	---------------------	--	--	----------	-----------------------	--

KVA	Données techniques	M55 C2	T10 C1	T15 C1	T20 C1	T25 C1	T35	KVA
TECHNIQUES	Norme d'émissions 2002/88	OUI	Exempt	Exempt	Exempt	OUI	OUI	TECHNIQUES
	Norme acoustique 2000/14/CE	OUI	OUI	OUI	OUI	OUI	OUI	
	Secours / Continue [KVA]	55 / 49	10 / 9	14 / 12,5	19,5 / 17,5	25 / 23	35 / 31,5	
	Voltage [V] / Intensité [A] / Cos φ	230 / 239 / 0,9	400 / 14 / 0,8	400 / 21 / 0,8	400 / 28 / 0,8	400 / 36 / 0,8	400 / 50 / 0,8	
MOTEUR	Dimensions longueur x largeur x hauteur [mm]	2250/950/1292	1800/740/1170	1800/740/1170	1800/740/1170	1800/740/1170	2200/1000/1260	MOTEUR
	Dim emballage long x largeur x hauteur [mm]	2300/1000/1300	1800/750/1170	1800/750/1170	1800/750/1170	1800/750/1170	2230/1080/1260	
	Puissance acoustique LWA [dBA]	89	87	87	89	86	94	
	Pression acoustique LPA [dBA] 16m/10m/7m/4m	57/61/64/69	55/59/62/67	55/59/62/67	57/61/64/69	54/58/61/66	62/66/69/74	
	Réservoir [l] / Autonomie 75% (PRP) [h]	100 / 9,5	50 / 33	50 / 23	50 / 17	50 / 12,5	80 / 14	
	Unités par container 20' / 40'	6 / 12	9 / 19	9 / 19	9 / 19	9 / 19	6 / 12	
	Code moteur	18150	12531	12536	12535	18476	DEU-0020	
	Modèle	BF4M2011C	LPW2	LPW3	LPW4	D2009L04	F4M2011	
	Fabricant	DEUTZ	LISTER	LISTER	LISTER	DEUTZ	DEUTZ	
	Couplage	SAE3 1 1/2	SAE5 7 1/2	SAE5 7 1/2	SAE5 7 1/2	SAE5 7 1/2	SAE3 1 1/2	
Refroidissement / N° cylindres / Aspiration	Huile/4/Turbo	Eau/2/Nat	Eau/3/Naturelle	Eau/4/Naturelle	Eau/4/Turbo	Huile/4/Naturelle		
RC	Manual - Remote panel	G5 C1D0	G5 C1LW	G5 C1LW	G5 C1LW	G5 C1D0	G5 C1D0	RC
	Code groupe électrogène	M55C2 RC	T10C1 RC	T15C1 RC	T20C1 RC	T25C1 RC	T35 RC	
	Prix public	15.990 €	6.800 €	7.377 €	8.250 €	9.348 €	11.367 €	
ALT	Code alternateur	207	18805	18798	18803	18802	1151	ALT
	Modèle	LSA 43.2 L8	LSA 40 VS1	LSA 40 VS2	LSA 40 S4	LSA 40 L7	LSA 42.2 L9	
	Fabricant	LERROY SOMER	LERROY SOMER	LERROY SOMER	LERROY SOMER	LERROY SOMER	LERROY SOMER	
RC	Coffret type	Manuel-Distance	Manuel-Distance	Manuel-Distance	Manuel-Distance	Manuel-Distance	Manuel-Distance	RC
	Carté électronique	GPM3	GPM3	GPM3	GPM3	GPM3	GPM3	
	Coffret de contrôle / Cableage de contrôle	16169/129	16169/129	16169/129	16169/129	16169 / 18526	16778/226	
A	Automatic Mains Failure AMF panel	G5 C1D0	G5 C1LW	G5 C1LW	G5 C1LW	G5 C1D0	G5 C1D0	A
	Code groupe électrogène	M55C2 A	T10C1 A	T15C1 A	T20C1 A	T25C1 A	T35 A	
	Prix public	15.750 €	6.990 €	7.500 €	8.317 €	9.602 €	11.551 €	
ALT	Code alternateur	207	18805	18798	18803	18802	1151	ALT
	Modèle	LSA 43.2 L8	LSA 40 VS1	LSA 40 VS2	LSA 40 S4	LSA 40 L7	LSA 42.2 L9	
	Fabricant	LERROY SOMER	LERROY SOMER	LERROY SOMER	LERROY SOMER	LERROY SOMER	LERROY SOMER	
AUTO	Coffret type	Automatique AMF	Automatique AMF	Automatique AMF	Automatique AMF	Automatique AMF	Automatique AMF	AUTO
	Carté électronique	GECO MD	GECO MD	GECO MD	GECO MD	GECO MD	GECO MD	
	Coffret de contrôle / Cableage de contrôle	14840/129	14840/129	14840/129	14840/129	14840 / 18526	16781/226	
KITS	Kit maint 1000 h MOTEUR	DEU-1090/116€	2276 / 108€	2278 / 116€	2278 / 116€	Consulter	DEU-1090/116€	KITS
	Kit maint/secours 1000 h MOTEUR	DEU-1101/135€	2277 / 143€	2279 / 143€	2279 / 143€	Consulter	DEU-1098/133€	
Options	<i>Options disponibles (Code / Prix public)</i>							Options
ALT	LSA: Leroy Somer alternator	SERIE	SERIE	SERIE	SERIE	SERIE	SERIE	ALT
	LSA-TR: Leroy Somer tropicalized	XXXXXX / 271€	XXXXXX / 271€	XXXXXX / 271€	XXXXXX / 271€	XXXXXX / 271€	14175 / 271€	
	LSA-PMG: Leroy Somer PMG system	Consulter	Consulter	Consulter	Consulter	Consulter	Consulter	
INS/ATS	LSACALD: Leroy Somer with preheating	XXXXXX / 203€	XXXXXX / 203€	XXXXXX / 203€	XXXXXX / 203€	XXXXXX / 162€	14251 / 162€	INS/ATS
	1ATS: Integrated ATS for RC models	N.D.	N.D.	N.D.	N.D.	N.D.	N.D.	
	1ATS: Separated ATS for RC models	Consulter	1976 / 170€	1976 / 170€	1976 / 170€	1976 / 170€	1989 / 294€	
Coffret	2ATS: Separated ATS for A models	Consulter	1977 / 212€	1977 / 212€	1977 / 212€	1977 / 212€	1999 / 479€	Coffret
	TEMP: Automatic start/stop clock for RC	3017 / 131€	3017 / 131€	3017 / 131€	3017 / 131€	3017 / 131€	3017 / 131€	
	220V: Output voltage 220V for RC models	N.D.	15400 / 20€	15393 / 58€	15395 / 54€	15383 / 74€	15398 / 280€	
	220V: Output voltage 220V for A models	N.D.	15401 / 16€	15394 / 42€	15396 / 58€	15386 / 102€	15399 / 102€	
	GPM2: G2M2 controller (A+V/A+V+F)	N.D.	N.D.	N.D.	N.D.	N.D.	N.D.	
	GPM3: GPM3 digital controller for RC models	SERIE	SERIE	SERIE	SERIE	SERIE	SERIE	
	GECO-MD: GECOMD digital for A models	SERIE	SERIE	SERIE	SERIE	SERIE	SERIE	
	AMF25: AMF25 digital for A with EMR	15023 / 161€	15023 / 161€	15023 / 161€	15023 / 161€	15343 / 161€	15343 / 161€	
	PROTDIF: Differential protection A models	N.D.	15437 / 76€	15438 / 73€	15439 / 80€	15467 / 121€	15468 / 119€	
	BASES: Shokets for RC models	N.D.	15145 / 118€	15145 / 118€	15145 / 118€	16014 / 200€	16015 / 200€	
Moteur	DESCBAT: Battery disconnecter	15345 / 88€	15345 / 88€	15345 / 88€	15345 / 88€	15345 / 88€	15345 / 88€	Moteur
	VDO: Press & Temp transmitt. (GPM3/AMF25)	15967 / 130€	15965 / 88€	15965 / 88€	15965 / 88€	18803 / 250€	15967 / 130€	
	EMR-A: Engine electronic governor for A	Consulter	N.D.	N.D.	N.D.	N.D.	15209 / 810€	
	EMR-RC: Engine electronic governor for RC	Consulter	N.D.	N.D.	N.D.	N.D.	15209 / 810€	
	EMR-BUS: Engine MODBUS (needs AMF25)	Consulter	15349 / 325€	15349 / 325€	15349 / 325€	N.D.	15349 / 325€	
	AIRCALD: Air pre-heating for RC models	SERIE	19156 / 70€	19156 / 70€	19156 / 70€	N.D.	19157 / 145€	
	AIRCALD: Air pre-heating for A models	SERIE	19158 / 75€	19158 / 75€	19158 / 75€	N.D.	19159 / 150€	
Inst	LIQCALD: Liquid pre-heating	N.D.	13086 / 482€	13086 / 482€	13086 / 482€	13081 / 411€	N.D.	Inst
	RESID: Residential muffler	SERIE	SERIE	SERIE	SERIE	SERIE	SERIE	
	2_5FLEX50 (LISTER) / Ø60 (DEUTZ)	Consulter	...934-032/55€	...934-032/55€	...934-032/55€	...934-032/55€	12874 / 57€	
Chariot	5FLEX50 (LISTER) / Ø60 (DEUTZ)	Consulter	...934-033/92€	...934-033/92€	...934-033/92€	...934-033/92€	12875 / 98€	Chariot
	CAPOT: Open canopy (Consult us)	Consulter	16935/-500€	16936/-500€	16938/-500€	16938/-500€	N.D.	
	C.OBRA: Not aproved trailer	Consulter	1Axle / Ball	1Axle / Ball	1Axle / Ball	1Axle / Ball	1 Axle / Ball	
Comb	C.HOMOL: Aproved trailer (In Spain)	Consulter	15518 / 920€	15518 / 920€	15518 / 920€	15518 / 920€	956/1056€	Comb
	C.ART: Articulated rod	Consulter	1Axle / Ball	1Axle / Ball	1Axle / Ball	1Axle / Ball	1 Axle / Ball	
	C.ARG: O-hitch or ballmounted coupling	Consulter	15519 / 1700€	15519 / 1700€	15519 / 1700€	15519 / 1700€	2413/2289€	
	B.RETEN: 110% liquids retention tray	SERIE	SERIE	SERIE	SERIE	SERIE	12823 / 500€	
	B.SOLD: Internally welded retention tray	SERIE	SERIE	SERIE	SERIE	SERIE	15692 / 124€	
Comb	DECCOMB: Fuel decanter filter or pre-filter	15970 / 361€	SERIE	SERIE	SERIE	SERIE	15970 / 361€	Comb
	190L (C1): 250L (C2): 420L (T35)	Consulter	13493 / 273€	13493 / 273€	13493 / 273€	13493 / 273€	3175 / 522€	
	B-TR-MN: Semi-Automatic fuel electropump	3046 / 500€	N.D.	N.D.	N.D.	N.D.	3046 / 500€	
B-TR-AU: Automatic fuel electropump	12488 / 543€	N.D.	N.D.	N.D.	N.D.	12488 / 543€		



Foto: 65 CIDO T35 RC (CON C.HOMOL)

GRUPOS ELECTROGENES INSONORISADOS = TRIFASE 1500tr/mn

G5 Tarif GRUPOS 50HZ

C CONTINU 1500rpm 24h/day --- 2000h/year **I** INSONORISE

L/D L Lister-Petter **W/O** Système de REFRIGERISSEMENT

RC Manuel - À distance **A** Automatique AMF panel

D Deutz **W A O** Eau Air Huile

50 HERTZ

1500 RPM

KVA	Données techniques	T35 C2	T47	T47 C2	T65 C2	T100	T115	KVA		
DONNEES TECHNIQUES	Norme d'émissions 2002/88	OUI	OUI	OUI	OUI	NON	OUI	DONNEES TECHNIQUES		
	Norme acoustique 2000/14/CE	OUI	OUI	OUI	OUI	NON	NON			
	Secours / Continue [kVA]	35 / 31,5	47 / 40	47 / 40	65 / 58	100 / 90	115 / 104			
	Voltage [V] / Intensité [A] / Cos φ	400 / 50 / 0,8	400 / 67 / 0,8	400 / 93 / 0,8	400 / 93 / 0,8	400 / 145 / 0,8	400 / 166 / 0,8			
	Dimensions longueur x largeur x hauteur [mm]	2250/950/1292	2200/1000/1260	2250/950/1292	2250/950/1292	3000/1100/1480	3000/1100/1480			
	Dim emballage long x largeur x hauteur [mm]	2300/1000/1300	2200/1080/1260	2250/950/1300	2250/950/1300	3050/1130/1480	3050/1130/1480			
	Puissance acoustique LWA [dBA]	90	94	90	89	99	101			
	Pression acoustique LPA [dBA] 16m/10m/7m/4m	58/62/65/70	62/66/69/74	58/62/65/70	57/62/64/69	67/71/74/79	69/73/76/81			
	Réservoir [l] / Autonomie 75% (PRP) [h]	100 / 17	80 / 11	100 / 13,5	100 / 9,5	150 / 10	150 / 8			
	Unités par container 20' / 40'	6 / 12	5 / 10	6 / 12	6 / 12	2 / 6	2 / 6			
ALT	Code alternateur	1151	1134	642	642	392	392	ALT		
	Modèle	LSA 42.2 L9	LSA43.2S15	LSA43.2M45	LSA43.2M45	LSA44.2VS45	LSA44.2VS45			
	Fabricant	LEROY SOMER	LEROY SOMER	LEROY SOMER	LEROY SOMER	LEROY SOMER	LEROY SOMER			
	Système de regulation	AVR	AVR	AVR	AVR	AVR	AVR			
MOTEUR	Code moteur	DEU-0020	DEU-0021	18150	18150	999	714	MOTEUR		
	Modèle	F4M2011	BF4M2011	BF4M2011C	BF4M2011C	BF4M1013E	BF4M1013EC			
	Fabricant	DEUTZ	DEUTZ	DEUTZ	DEUTZ	DEUTZ	DEUTZ			
	Couplage	SAE3 11½	SAE3 11½	SAE3 11½	SAE3 11½	SAE2 11½	SAE2 11½			
RC	Refrigerissement / N° cylindres / Aspiration	Huile/4/Naturelle	Huile/4/Turbo	Huile/4/Turbo	Huile/4/Turbo	Eau/4/Turbo	Eau/4/Turbo	RC		
	Code groupe électrogène	T35C2 RC	T47 RC	T47C2 RC	T65C2 RC	T100 RC	T115 RC			
	Prix public	11.890 €	12.386 €	12.815 €	14.785 €	18.169 €	19.656 €			
	Poids net / Poids avec emballage [kg]	1050 / 1065	945 / 955	1250 / 1275	1150 / 1185	1430 / 1435	1490 / 1500			
A	Coffret type	Manuel-Distance	Manuel-Distance	Manuel-Distance	Manuel-Distance	Manuel-Distance	Manuel-Distance	A		
	Carté électronique	GPM3	GPM3	GPM3	GPM3	GPM3	GPM3			
	Coffret de contrôle / Cableage de contrôle	16169/226	16778/226	14854/226	16169/226	16778/646	16777/646			
	Coffret de force / Cableage de force	1665/1668	1900/1668	1682/1668	1682/1668	1916/1694	1925/1755			
AUTO	Code groupe électrogène	T35C2 A	T47 A	T47C2 A	T65C2 A	T100 A	T115 A	AUTO		
	Prix public	11.950 €	12.501 €	12.950 €	14.671 €	18.175 €	19.616 €			
	Poids net / Poids avec emballage [kg]	1050 / 1065	945 / 955	1250 / 1275	1150 / 1185	1430 / 1440	1490 / 1500			
	Coffret type	Automatique AMF	Automatique AMF	Automatique AMF	Automatique AMF	Automatique AMF	Automatique AMF			
KITS	Carté électronique	GECO MD	GECO MD	GECO MD	GECO MD	GECO MD	GECO MD	KITS		
	Coffret de contrôle / Cableage de contrôle	14840 / 226	16781/226	14840 / 226	14840 / 226	16781/646	16782/646			
	Coffret de force / Cableage de force	1680 / 1668	1902/1668	1684 / 1668	1684 / 1668	1922/1694	1930/1755			
	Kit mant 1000 h MOTEUR	DEU-1090/116€	DEU-1090/116€	DEU-1090/116€	DEU-1090/116€	DEU-1114/161€	DEU-1114/161€			
Options	Kit mant/secours 1000 h MOTEUR	DEU-1098/133€	DEU-1101/135€	DEU-1101/135€	DEU-1101/135€	DEU-1115/272€	DEU-1115/272€	Options		
	Options disponibles (Code / Prix public)									
	ALT	LSA: Leroy Somer alternator	SERIE	SERIE	SERIE	SERIE	SERIE		ALT	
	INS/ATS	LSA-TR: Leroy Somer tropicalized	14175 / 271€	14176 / 271€	14176 / 271€	12419 / 271€	15309 / 280€			15309 / 280€
Coffret	LSA-PMG: Leroy Somer PMG system	Consulter	Consulter	Consulter	Consulter	Consulter	Consulter	Coffret		
	LSACALD: Leroy Somer with preheating	14251 / 162€	15153 / 215€	15153 / 215€	15489 / 215€	15155 / 215€	15155 / 215€			
	Moteur	1ATS: Separated ATS for RC models	1989 / 294€	1989 / 294€	1989 / 294€	1989 / 294€	3262 / 477€		3262 / 477€	Moteur
	2ATS: Separated ATS for A models	1999 / 479€	1999 / 479€	1999 / 479€	1999 / 479€	3265 / 920€	3265 / 920€			
Inst	TEMP: Automatic start/stop clock for RC	3017 / 131€	3017 / 131€	3017 / 131€	3017 / 131€	3017 / 131€	3017 / 131€	Inst		
	220V: Output voltage 220V for RC models	15398 / 280€	15391 / 279€	15391 / 279€	15454 / 409€	15480 / 608€	15482 / 826€			
	220V: Output voltage 220V for A models	15399 / 102€	15392 / 102€	15392 / 102€	15455 / 375€	15481 / 571€	15483 / 848€			
	GPM2: GPM2 controller (A+V/A+F/V+F)	N.D.	N.D.	N.D.	N.D.	N.D.	N.D.			
Chariot	GPM3: GPM3 digital controller for RC models	SERIE	SERIE	SERIE	SERIE	SERIE	SERIE	Chariot		
	GECO-MD: GECOMD digital for A models	SERIE	SERIE	SERIE	SERIE	SERIE	SERIE			
	AMF25: AMF25 digital for A with EMR	15343 / 161€	15343 / 161€	15343 / 161€	15023 / 161€	15343 / 161€	15343 / 161€			
	PROTDIF: Differential protection A models	15468 / 119€	15469 / 119€	15469 / 119€	15443 / 170€	15471 / 147€	15472 / 193€			
Comb	BASES: Shokets for RC models	16015 / 200€	16016 / 300€	16016 / 300€	Consulter	18052 / 412€	18052 / 412€	Comb		
	DESCBAT: Battery disconnect	15345 / 88€	15345 / 88€	15345 / 88€	15345 / 88€	15345 / 88€	15345 / 88€			
	VDO: Press & Temp transmitt. (GPM3/AMF25)	15967 / 130€	15967 / 130€	15967 / 130€	15967 / 130€	15968 / 140€	15968 / 140€			
	EMR-A: Engine electronic governor for A	15209 / 810€	14892 / 810€	14892 / 810€	XXXX / 810€	15217/1107€	15218/1107€			
Chariot	EMR-RC: Engine electronic governor for RC	15209 / 810€	14892 / 810€	14892 / 810€	XXXX / 810€	15217/1107€	15218/1107€	Chariot		
	EMR-BUS: Engine MODBUS (needs AMF25)	15349 / 325€	15349 / 325€	15349 / 325€	15349 / 325€	15349 / 325€	15349 / 325€			
	AIRCALD: Air pre-heating for RC models	19157 / 145€	SERIE	SERIE	SERIE	N.D.	N.D.			
	AIRCALD: Air pre-heating for A models	19159 / 150€	SERIE	SERIE	SERIE	N.D.	N.D.			
Inst	LIQCALD: Liquid pre-heating	N.D.	N.D.	N.D.	N.D.	13081 / 411€	13081 / 411€	Inst		
	RESID: Residential muffler	SERIE	SERIE	SERIE	SERIE	SERIE	SERIE			
	2.5FLEX60 (T35-T47) / Ø100 (T70-T150)	12874 / 57€	12874 / 57€	12874 / 57€	12874 / 57€	15324 / 85€	15324 / 85€			
	5FLEX60 (T35-T47) / Ø100 (T70-T150)	12875 / 98€	12875 / 98€	12875 / 98€	12875 / 98€	15325 / 162€	15325 / 162€			
Chariot	C.OBRA: Not approved trailer	1 Axle / Ball Consult us	1 Axle / Ball 956/1056€	1 Axle / Ball 956/1056€	1 Axle / Ball us	2 Axle / ARG 1339/1211€	2 Axles / ARG 1339/1211€	Chariot		
	C.HOMOL: Approved trailer (In Spain)	1 Axle / Ball Consult us	1 Axle / Ball 2413/2289€	1 Axle / Ball 2413/2289€	1 Axle / Ball Consult us	2 Axle / ARG 1326/3925€	2 Axle / ARG 1326/3925€			
	C.ART: Articulated rod	Consulter	Consulter	Consulter	Consulter	Consulter	Consulter			
	C.ARG: O-hitch or ballmounted coupling	Consulter	Consulter	Consulter	Consulter	Consulter	Consulter			
Comb	B.RETEN: 110% liquids retention tray	SERIE	12823 / 500€	SERIE	SERIE	12825 / 836€	12825 / 836€	Comb		
	B.SOLD: Internally welded retention tray	SERIE	15692 / 124€	SERIE	SERIE	15694 / 201€	15694 / 201€			
	DECCOMB: Fuel decanter	15970 / 361€	15970 / 361€	15970 / 361€	15970 / 361€	SERIE	SERIE			
	190L (C1): 250L (C2): 420L (T35)	18158 / 350€	3175 / 522€	18158 / 350€	18158 / 350€	3177 / 645€	3177 / 645€			
Comb	B-TR-MN: Semi-Automatic fuel electropump	3046 / 500€	3046 / 500€	3046 / 500€	3046 / 500€	3046 / 500€	3046 / 500€	Comb		
	B-TR-AU: Automatic fuel electropump	12488 / 542€	12488 / 542€	12488 / 542€	12488 / 542€	12488 / 542€	12488 / 542€			



GRUPEES ELECTROGENES INSONORISEES = TRIPHASE 1500tr/mn

G5		Tarif GRUPEES 50HZ	
C	CONTINU 1500rpm 24h/day --- 2000h/year MOTEUR	I	INSONORISE
L/D	L Lister-Petter	W/O	Système de REFRIGERATION W Air Eau A Air O Huile
RC	d Deutz	A	Automatique AMF panel
	Manuel - À distance		

50 HERTZ

1500 RPM

KVA	Datos técnicos RC / A	T140	T175	T200	T275	KVA
DONNEES TECHNIQUES	Norme d'émissions 2002/88	YES	YES	YES	YES	DONNEES TECHNIQUES
	Secours / Continue [kVA]	140 / 125	175 / 157	200 / 180	275 / 250	
	Voltage [V] / Intensité [A] / Cos φ	400 / 200 / 0,8	400 / 250 / 0,8	400 / 290 / 0,8	400 / 396 / 0,8	
	Dimensions longueur x largeur x hauteur [mm]	3000/1100/1480	3500/1100/1480	3550/1330/2000	3550/1330/2000	
	Dim emballage long x largeur x hauteur [mm]	3050/1130/1480	3500/1100/1480	3550/1330/2000	3550/1330/2000	
	Puissance acoustique LWA [dBA]	103	108	108	104	
	Pression acoustique LPA [dBA] 16m/10m/7m/4m	71/75/78/83	76/80/83/88	76/80/83/88	72/76/79/84	
	Réservoir [l] / Autonomie 75% (PRP) [h]	150 / 6	150 / 6	330 / 10	330 / 8	
	Unités par container 20' / 40'	2 / 6	2 / 6	1 / 3	1 / 3	
	ALT	Code alternateur	639	2121	13724	
Modèle		LSA 44.2 S75	LSA44.2L12	LSA46.2M3	LSA46.2L6	
Fabricant		LEROY SOMER	LEROY SOMER	LEROY SOMER	LEROY SOMER	
Système de regulation		AVR	AVR	AVR	AVR	
Alternateur IP protection		IP23	IP23	IP23	IP23	
MOTEUR	Code moteur	Consulter	2853	13834	14482	MOTEUR
	Modèle	BF4M1013FC	BF6M1013EC	BF6M1013FCP	TCB2013L064	
	Régulation électronique (Précision= ±0%)	EMR2 type	As option	EMR2 type	EMR3 type	
	Fabricant	DEUTZ	DEUTZ	DEUTZ	DEUTZ	
	Couplage	SAE2 11½	SAE2 11½	SAE2 11½	SAE2 11½	
Refrigerissement / N°cylinders / Aspiration	Eau/4/Turbo	Eau/6/Turbo	Eau/6/Turbo	Eau/6/C.Rail		
RC	Manuel / À distance - RC	G5 CIDW T140 RC	G5 CIDW T175 RC	G5 CIDW T200 RC	G5 CIDW T275 RC	RC
	Code groupe électrogène	17499	14723	14264	14415	
	Prix public	21.760 €	25.844 €	31.453 €	33.738 €	
	Poids net / Poids avec emballage [kg]	1800 / 1820	2350 / 2370	2400 / 2420	2600 / 2630	
RC	Coffret type	Manuel-Distance	Manuel-Distance	Manuel-Distance	Manuel-Distance	RC
	Carté électronique	GPM3	GPM3	GPM3	GPM3	
	Coffret de contrôle / Cableage de contrôle	16779/18472	16777/18472	16779/3064	16779/14699	
	Coffret de force / Cableage de force	3255/2417	3255/2417	2897/2417	2897/1755	
A	Automatique AMF panel - A	G5 CIDW T140 A	G5 CIDW T175 A	G5 CIDW T200 A	G5 CIDW T275 A	A
	Code groupe électrogène	18479	3650	14265	14416	
	Prix public	21.990 €	25.715 €	31.338 €	33.627 €	
	Poids net / Poids avec emballage [kg]	1800 / 1825	2375 / 2395	2400 / 2420	2600 / 2630	
AUTO	Coffret type	Automatique AMF	Automatique AMF	Automatique AMF	Automatique AMF	AUTO
	Carté électronique	GECO MD	GECO MD	GECO MD	GECO MD	
	Coffret de contrôle / Cableage de contrôle	16783/2973	16782/2973	16783/3064	167774 / 14699	
	Coffret de force / Cableage de force	2439/2417	2439/2417	15029/2417	16092 / 1755	
KITS	Kit mant 1000 h MOTEUR	Consulter	DEU-1117/203€	DEU-1119/217€	15495 / 658€	KITS
	Kit mant/secours 1000 h MOTEUR	Consulter	DEU-1118/315€	DEU-1120/328€	15329 / 79€	
Options	Options disponibles (Code / Prix public)				Options	
ALT	LSA: Leroy Somer alternator	SERIE	SERIE	SERIE	SERIE	ALT
	LSA-TR: Leroy Somer tropicalized	15310 / 280€	15311 / 280€	15312 / 309€	15313 / 309€	
	LSA-PMG: Leroy Somer PMG system	Consulter	Consulter	Consulter	Consulter	
	LSACALD: Leroy Somer with preheating	15491 / 215€	15492 / 215€	15493 / 215€	15494 / 215€	
INS/ATS	1ATS: Separated ATS for RC models	3262 / 477€	3262 / 477€	2982 / 827€	15348 / 1000€	INS/ATS
	2ATS: Separated ATS for A models	3265 / 920€	3265 / 920€	12956 / 1644€	12956 / 1644€	
	TEMP: Automatic start/stop clock for RC	3017 / 131€	3017 / 131€	3017 / 131€	3017 / 131€	
	GPM2: GM2 controller (A+V/A+F/V+F)	N.D.	N.D.	N.D.	N.D.	
Coffret	GPM3: GPM3 digital controller for RC models	SERIE	SERIE	SERIE	SERIE	Coffret
	GECO-MD: GECOMD digital for A models	SERIE	SERIE	SERIE	SERIE	
	AMF25: AMF25 digital for A with EMR	15343 / 161€	15343 / 161€	15343 / 161€	15343 / 161€	
	PROTDIF: Differential protection A models	15473 / 182€	15474 / 182€	15477 / 288€	15478 / 288€	
	BASES: Shokets for RC models	18052 / 412€	18052 / 412€	18052 / 412€	18052 / 412€	
	DESCBAT: Battery disconnecter	15345 / 88€	15345 / 88€	15345 / 88€	15345 / 88€	
	VDO: Press & Temp transmitt. (GPM3/AMF25)	15968 / 140€	15968 / 140€	Voir EMR-BUS	Voir EMR-BUS	
	EMR-A: Engine electronic governor for A	SERIE	12613/1006€	SERIE	SERIE	
Moteur	EMR-RC: Engine electronic governor for RC	SERIE	12613/1006€	SERIE	SERIE	Moteur
	EMR-BUS: Engine MODBUS (needs AMF25)	15349/325€	15349/325€	15349/325€	15349/325€	
	AIRCALD: Air pre-heating for RC models	N.D.	N.D.	N.D.	N.D.	
	AIRCALD: Air pre-heating for A models	N.D.	N.D.	N.D.	N.D.	
	LIQCALD: Liquid pre-heating	13081/411€	13081/411€	13081/411€	17854/411€	
	RESTD: Residential muffler	SERIE	SERIE	SERIE	SERIE	
Inst	2,5FLEX100 (T175) / Ø120 (T200-T275)	15324 / 85€	15324 / 85€	15326 / 122€	15326 / 122€	Inst
	5FLEX100 (T175) / Ø120 (T200-T275)	15325 / 162€	15325 / 162€	15327 / 226€	15327 / 226€	
	C.OBRA: Not aproved trailer	2 Axles / ARG 3081/1611€	2 Axles / ARG 3081/1611€	Consulter	Consulter	
Chariot	C.HOMOL: Aproved trailer (In Spain)	2 Axles / ARG 12094/4044€	2 Axles / ARG 12094/4044€	2 Axles / ARG 15560 / 4306€	2 Axles / ARG 15560 / 4306€	Chariot
	C.ART: Articulated rod	15355 / 1017€	15355 / 1017€	Consulter	Consulter	
	C.ARG: O-hitch or ballmounted coupling	SERIE	SERIE	SERIE	SERIE	
	B.RETEN: 110% liquids retention tray	12826 / 927€	12826 / 927€	12771 / 1041€	12771 / 1041€	
Comb	B.SOLD: Internally welded retention tray	15695 / 268€	15695 / 268€	15696 / 325€	15696 / 325€	Comb
	DECCOMB: Fuel decanter	SERIE	SERIE	SERIE	SERIE	
	800L (T140-175); 850L (200-275KVA)	12965/771€	12965/771€	16380/ 771€	16380/ 771€	
	B-TR-MN: Semi-Automatic fuel electropump	3046 / 500€	3046 / 500€	3046 / 500€	3046 / 500€	
	B-TR-AU: Automatic fuel electropump	12488 / 542€	12488 / 542€	12488 / 542€	12488 / 542€	

MAMA / MARA / MALW

M = Motosoudeuse

A = Ouvert

M / R / L = Minsel / Lombardini / Lister

A / W = Air / Eau

3000 tr/mn

4h / jour

400h / an



Securité et Equipment

Tous les groupes ont des **protections indispensables** pour la securité de l'operateur et de la charge

Toutes les parties metalliques du groupe sont connectées à une prise de terre.

Fiabilité

Le coffret et le couple moteur-alternateur sont montés sur des **silent-blocks** qui garantissent l'isolement des vibrations issues du fonctionnement, et permettent ainsi, d'allonger la vie du g'nerateur

Gamme de produits

MOTEURS

- Moteur Diesel MINSEL/LOMBARDINI/LISTER
- 4 stroke
- Refroidissement par air (Série MAMA/MARA)
- Refroidissement par eau (Série MALW)
- Démarrage électrique 12V
- Radiateur à ventilation soufflante (MALW)
- Filtre decanter du carburant (MALW)
- Régulation mechanic
- Protections pour les parties mobiles
- Filtre à air sec
- Lubrification forcée par pompe
- Silencieux

SOUDEUSES

- Monophasé (180A) Altern courant
- Monophasé (220A) Continue courant
- Triphasé (300A) Continue courant
- Compound et AVR
- IP23 Protection
- T.H.D. <6%
- Voltage (180A) 45-60V
- Voltage (220A) 65-85V
- Electrodes utilisables: Rutile & Acidic (180ac)
- Electrodes utilisables: All types (220ac)
- Electrodes utilisables: All types (300dc)
- Selecteur 8x2 permitting change (180A)
- Protections inclus pour la charge

CHÂSSIS

- Chassis tubulaire compact en acier (MAMA/MARA)
- Chassis rectangulaire en acier (MALW)
- Réservoir de carburant métallique situé dans le moteur.
- Réservoir de carburant métallique situé sous le moteur-alternateur et independant du chassis. (MALW)
- Roues incorporées. (MAMA/MARA)
- Disponible : chariot de chantier. (MALW)
- Silentblocks de support sur le sol. (MAMA/MARA)
- Peinture "EPOXI" anti-oxydation
- Batterie et cables de connexion
- Coffret complètement intégré
- Silent-blocks pour le moteur, l'alternateur.

		MOTOSOUDEUSES				
		G5	TARIF GRUPOS ELECTROGENES 50HZ			
		M	MOTOSOUDEUSES 3000rpm 4h/jour -- 800h/an		A	
		M/R/L	MOTOR		OPEN SKID	
		M / T	M L R	MINSEL LISTER LOMBARDINI	SYSTEME DE REFROIDISSEMENT	
			MONOPHASÉ/TRIPHASÉ		A A W AIR EAU	
			E / S		ELECTRIQUE / SOLENOID	
		AMP	180A	220A	300A	AMP
DONNÉES TECHNIQUES	Datos técnicos RC / A	180A	220A	300A		
	Puissance [Amp]	180A	220A	300A		
	Type (Altern AC / Continu DC)	AC	DC	DC		
	Dimensions Longueur/Largeur/Hauteur [mm]	823/800/723	823/800/723	1450/750/1170		
	Dimensions avec emballage [mm]	940/840/1010	940/840/1010	1500/800/1250		
	Puissance acoustique LWA [dBA]	109	103	104		
	Pression acoustique LPA [dBA] 16m/10m/7m/4m	77/81/84/89	71/75/78/83	72/76/79/84		
	Réservoir [l] / Autonomie 75% [h]	4 / 3	18 / 8	37 / 11		
Unités par container 20' / 40'	28 / 56	28 / 56	10 / 21			
SOUDEUSE	Code soudeuse	.MTS-0016	.MTS-0015	19073		
	Modèle	W180 AC	W220 DC	WS300 TDC		
	Fabricant	SACCARDO	SACCARDO	SACCARDO		
	Type de régulation	COMPOUND	COMPOUND	AVR		
	Service 35% [A]	180	220	300		
	Service 60% [A]	125	170	240		
	Diámetro de l'électrode [mm]	4	4 - 5	5 - 6		
	Puissance générateur [kVA]	M5	M4	M4 / T9		
Soudage IP protection	IP23	IP23	IP23			
MOTEUR	Code moteur	1430-5002	.336-0030	2085		
	Modèle	M430	25LD330/0	LPW3/0		
	Fabricant	MINSEL	LOMBARDINI	LISTER		
	Couplage	RI Ø23	RI Ø30	SAE5 7½		
	Refroidissement / N° cylindres / Aspiration	Air / 1 / Naturelle	Air / 2 / Naturelle	Eau/3/Naturelle		
E	Electric start with key	G5 MAMA AC180M E	G5 MARA DC220M E	G5 MALW DC300T S		
	Prix public	Code motosoudeuse MTS-0021	2286	19093		
	Prix public	2.361 €	3.898 €	5.788 €		
E / S	Poids net / Poids avec emballage [kg]	130 / 146	170 / 185	520 / 535		
	Coffret type	E = ELECTR	E = ELECTR	S = SOLENOID		
	Système de démarrage	CLÉ	CLÉ	CLÉ		
KITS	Code du coffret	.219-3550	.219-3550	Consulter		
	Equipment	Alarms	Alarms	Alarms & STOP		
	Temp & Press	Temp & Press	Temp & Press	Temp & Press		
KITS	Kit maint 1000 h MOTEUR	1430-1150/54€	.336-1051/90€	2x14589 / 108€		
	Kit maint/secours 1000 h MOTEUR	1430-1152/82€	.336-1020/ 146€	2280 / 134€		
	Kit roues pour transport manuel / Chariot non homologué	SERIE	SERIE	1 Axle / Ball 3487 / 844€		

SACO

Groupe tracteur

S = 1500tr/mn

A = Ouvert

C = Comer (Gear box)

O = Huile

8h / jour

800h / an



Securité et equipment

Tous les groupes ont des protections indispensables pour la sécurité de l'opérateur et de la charge

Gamme de produits

GEAR BOX

- COMER MANUFACTURER
- RPM = 435 ÷ 460
- Relation rpm = 1:6,9 (3000rpm) 1:3,28 (1500rpm)
- Refroidissement par huile
- Protection pour les parties mobiles



ALTERNATOR

- Synchronic
- Three Phase
- With brush
- Compound
- IP23 Protection
- T.H.D. <5%
- Tension precision = ±5%
- Starting high-current (Icc = 3 ÷ 4In)

FRAME/CONTROL PANEL

- Steel tube-shaped frame
- Bases
- Magnetothermic
- Voltmetre
- Frecuency meter
- Differential



		GRUPEs TRACTEURS						
SACO20 SACO25 SACO30		G5	TARIF GRUPEs 50HZ					SACO20 SACO25 SACO30
		S	S = 1500 tr/mn		A	OUVERTS		
		C	GEAR BOX		O	REFROIDISSEMENT		
			c	COMER		o	OIL / HUILE	
SACO42 SACO62 SACO72		T	TRIPHASÉ		C	CEE (With all necessary protection devices)		SACO42 SACO62 SACO72
KVA	Données techniques	SACO T20	SACO T25	SACO T30	SACO T42	SACO T62	SACO T72	KVA
TECHNIQUES DONNÉES	Power [KVA]	20 / 18	25 / 22	30 / 27	42 / 38	62 / 55	72 / 65	TECHNIQUES DONNÉES
	Tensión [V] / Intensidad [A] / Cos φ	400 // 0,8	400 // 0,8	400 // 0,8	400 // 0,8	400 // 0,8	400 // 0,8	
	Dimensiones largo x ancho x alto [mm]	918/843/925	918/843/925	918/843/925	1110/843/1322	1110/843/1322	1110/843/1322	
	Dim embalaje largo x ancho x alto [mm]	920/850/1010	920/850/1010	920/850/1010	1150/900/1400	1150/900/1400	1150/900/1400	
	Potencia acústica LWA [dBA]	NO	NO	NO	NO	NO	NO	
	Presión acústica LPA [dBA] 16m/10m/7m/4m	NO	NO	NO	NO	NO	NO	
	Depósito [l] / Autonomía 75% [h]	NO	NO	NO	NO	NO	NO	
	Unidades por container 20' / 40'	12 / 28	12 / 28	12 / 28	10 / 20	10 / 20	10 / 20	
Gearbox	Model	A-624	A-624	A-624	A-624	A-624	A-624	Gearbox
	Manufacturer	COMER	COMER	COMER	COMER	COMER	COMER	
	RPM	435	435	435	435	435	435	
	Relation / Rate	1 : 3,28	1 : 3,28	1 : 3,28	1 : 3,28	1 : 3,28	1 : 3,28	
ALT	Code	13965	13825	13969	17697	17660	17699	ALT
	Modèle	TW132 MA/4	TW132 LA/4	TW132 LB/4	TBM200 SA/4	TBM200 MA/4	TBM200 MB/4	
	Fabricant	SACCARDO	SACCARDO	SACCARDO	SACCARDO	SACCARDO	SACCARDO	
	Regulation	COMPOUND	COMPOUND	COMPOUND	AVR	AVR	AVR	
	IP index protection	IP23	IP23	IP23	IP23	IP23	IP23	
CEE	CEE	G5 SACO T20 C	G5 SACO T25 C	G5 SACO T30 C	G5 SACO T42 C	G5 SACO T62 C	G5 SACO T72 C	CEE
	Prix public	Tractor driven generator code	13965	13825	13969	17697	17660	17699
	Retail price	2.050 €	2.238 €	2.399 €	4.260 €	4.898 €	5.120 €	
	Net & Gross weight [kg]	186 / 190	204 / 210	216 / 220	385 / 400	430 / 445	470 / 490	
Coffret	Panel type	CEE-NSM	CEE-NSM	CEE-NSM	CEE-NSM	CEE-NSM	CEE-NSM	Coffret
	CPU controller	NON	NON	NON	NON	NON	NON	
	Voltmeter	OUI	OUI	OUI	OUI	OUI	OUI	
	Frequencymeter	OUI	OUI	OUI	OUI	OUI	OUI	
	Circuit breaker thermomagnetic	OUI	OUI	OUI	OUI	OUI	OUI	
	Differential	OUI	OUI	OUI	OUI	OUI	OUI	
	Shockets	OUI	OUI	OUI	OUI	OUI	OUI	



ABAMOTOR ENERGÍA, S.L.

Astola, 6-C - 48220 Abadiano (Vizcaya)

España / Spain / Espagne

Telfs: 34 - 94 620 27 17 ---- 34 94 620 27 41

Fax: 34 - 94 620 33 34

E-mail: abamotor@sarenet.es ***** <http://www.abamotor.com>