

Tarif 2009/2010

50Hz



These prices are valid until 2010/April/30

Generators 50Hz

Motorweldings

Tractor driven generators



ABAGEN

Abamotor Energía S.L.

PROFESSIONAL GENERATORS - 3000rpm - 8h/day - 800h/year



PROFESSIONAL GENERATORS - 3000rpm - 8h/day - 800h/year



SOUNDPROOF = SINGLE - PHASE 3000 R.P.M.				
G5	TARIF GENERATORS 50HZ 400V & 230V			3000
F	PROFESSIONAL 3000rpm 8h/day --- 800h/year	I	SOUNDPROOF	50
M/R/L	M R L	Minsel Lombardini Lister-Petter	A/O/W	A W O
			COOLING SYSTEM	Air Agua (Water) Aceite (Oil)
	RC	Manual-Remote control panel	A	AMF panel

3000 RPM

50 HERTZ

KVA	Technical data	FIMA M6	FIRA M9	FILW M13	KVA
TECHNICAL DATA	Compliance emission 2002/88	Exempt	Exempt	Exempt	TECHNICAL DATA
	Stand-by / Continuous [kVA]	5,5 / 5	9 / 8	13 / 11	
	Voltage [V] / Intensity [A] / Cos φ	230 / 24 / 0,9	230 / 37 / 0,9	230 / 56 / 0,9	
	Dimensions length x width x height [mm]	1200/560/830	1200/560/830	1800/740/1170	
	Dim packaging lengthxwidthxheight [mm]	1300/740/990	1300/740/990	1800/750/1230	
	Acoustic power LWA [dBA]	94	94	96	
	Acoustic pressure LPA [dBA] 16m/10m/7m/4m	62/66/69/74	62/66/69/74	64/68/71/76	
Fuel tank [l] / Autonomy 75% (PRP) [h]	40 / 28	40 / 18	50 / 16		
Units per container 20' / 40'	24 / 56	24 / 56	9 / 19		
ENGINE	Engine code	1430-3376	2060	12537	ENGINE
	Model	M430 FIMA	25LD330	LPW2	
	Manufacturer	MINSEL	LOMBARDINI	LISTER	
	Coupling	Cone Ø23mm	Cone Ø30mm	SAE5 7½	
	Cooling system / N° cylinders /Aspiration	Air/1/Natural	Air/2/Natural	Water/2/Natural	
RC	Manual-Remote control RC	G5 FIMA M6 RC	G5 FIRA M9 RC	G5 FILW M13C1 RC	RC
	Generator code	3383	2247	2797	
	Retail price	3.831 €	5.028 €	7.013 €	
	Net weight / With packaging [kg]	208 / 233	205 / 225	578 / 586	
ALT	Alternator code	14793	ALT-0076	13957	ALT
	Model	SE100 FX	M100 LL	TR112 MC	
	Manufacturer	SACCARDO	SACCARDO	SACCARDO	
	Regulation system	CONDENS	CONDENS	AVR	
	Protection index	IP21	IP21	IP23	
RC	Control panel type	REMOTE-CEE	REMOTE-CEE	REMOTE-CEE	RC
	CPU controller	GPMR72	GPMR72	GPMR72	
	Engine control panel / Engine wiring harness	3297/3125	2242/2945	14988/129	
	Power control panel / Power wiring harness	3297/...187-116	2242/...187-116	2545/890	
A	Automatic mains failure AMF	G5 FIMA M6 A	G5 FIRA M9 A	G5 FILW M13C1 A	A
	Generator code	3384	2249	2558	
	Retail price	4.114 €	5.347 €	7.000 €	
	Net weight / With packaging [kg]	215 / 239,8	230,7 / 251	577,6 / 586,2	
ALT	Alternator code	1637	1638	13957	ALT
	Model	MR100 SF	MR100 LL	TR112 MC	
	Manufacturer	SACCARDO	SACCARDO	SACCARDO	
	Regulation system	AVR	AVR	AVR	
	Protection index	IP23	IP23	IP23	
AMF	Control panel type	AMF panel	AMF panel	AMF panel	AMF
	CPU controller	GECO + V	GECO + V	GECO + V	
	Engine control panel / Engine wiring harness	3308/225	2245/225	1689/129	
	Power control panel / Power wiring harness	3308/...187-117	2245/...187-117	2581/890	
KITS	Kit maint 1000 h ENGINE	1430-1150/54€	336-1051/90€	2x14589 / 108€	KITS
	Kit maint/emerg 1000 h ENGINE	1430-1152/82€	336-1020/146€	2280 / 134€	
	Kit maint/emerg 1000 h ALTERNATOR (SE100)	1884 / 31€	-	-	
	Kit maint/emerg 1000 h ALTERNATOR (M100)	Consult us	Consult us	Consult us	
Option	Available options (Code / Retail price)				Option
ALT	AVR: NSM AVR (For "RC" models)	2156 / 151€	2141 / 195€	SERIE	ALT
	LSA: Leroy Somer alternator	N.A.	N.A.	N.A.	
ATS	1ATS: Separated ATS for RC models	15925 / 170€	15925 / 170€	15925 / 170€	ATS
	2ATS: Integrated ATS for RC models	15184 / 104€	15184 / 104€	N.A.	
	2ATS: Separated ATS for A models	15928 / 212€	15928 / 212€	15928 / 212€	
Panel	TEMP: Automatic start/stop clock for RC	3017 / 131€	3017 / 131€	3017 / 131€	Panel
	GPM2: GM2 controller (A+V/A+F/V+F)	N.A.	N.A.	N.A.	
	GPM3: GPM3 digital controller for RC models	N.A.	N.A.	14231 / 230€	
	GECO-MD: GECOMD digital for A models	N.A.	N.A.	14240 / 292€	
	AMF25: AMF25 digital for A with EMR	N.A.	N.A.	14184 / 453€	
	PROTDIF: Differential protection A models	15382 / 16€	15382 / 16€	15384 / 118€	
	BASES: Shokets for RC models	SERIE	SERIE	15147 / 114€	
	DESCBAT: Battery disconnecter	N.A.	N.A.	15345 / 88€	
Engine	VDO: Press & Pressure transmitt. (GPM3/AMF25)	N.A.	N.A.	15965 / 88€	Engine
	EMR: Engine electronic governor	N.A.	N.A.	N.A.	
	AIRCALD: Air pre-heating for RC models	N.A.	N.A.	13095 / 80€	
	AIRCALD: Air pre-heating for A models	N.A.	N.A.	11777 / 165€	
	OILCALD: Oil pre-heating	3139 / 261€	18756 / 281€	N.A.	
LIQCALD: Liquid pre-heating	N.A.	N.A.	13086 / 467€		
Inst	RESID: Residential muffler	SERIE	SERIE	SERIE	Inst
	2.5FLEX50: 2,5m flexible tube for silencer	...934-032/55€	...934-032/55€	...934-032/55€	
	5FLEX50: 5m flexible tube for silencer	...934-033/93€	...934-033/93€	...934-033/93€	
Trailer	C.OBRA: Not approved trailer	N.A.	N.A.	1Axle / BALL 15518 / 920€	Trailer
	C.HOMOL: Approved trailer (SPAIN)	N.A.	N.A.	1Axle / BALL 15519 / 1700€	
	C.ART: Articulated rod	N.A.	N.A.	Consult us	
	C.ARG: Ring type coupling	N.A.	N.A.	Consult us	
	RUEDAS: On skid wheels manual transport	Consult us	Consult us	N.A.	
Fuel	DECCOMB: Fuel decanter	N.A.	N.A.	SERIE	Fuel
	190L: Extra large 190L fuel tank	N.A.	N.A.	13493 / 273€	
	B-TR-MN: Semi-Automatic fuel electropump	N.A.	N.A.	N.A.	
	B-TR-AU: Automatic fuel electropump	N.A.	N.A.	N.A.	

3 ~



SOUNDPROOF = THREE PHASE 3000 R.P.M.

G5 GENERATORS TARIF 50HZ

3000 RPM

50 HERTZ

F	PROFESSIONAL 3000rpm 8h/día --- 800h/año	I	SOUNDPROOF
M/R/L	M R L	Minsel Lombardini Lister-Petter	A/O/W
RC	Manual-Remote panel		A
			Automatic AMF panel
			COOLING Aire Agua (Water) Aceite (Oil)

KVA	Tecnical data	FIMA T7	FIRA T10	FILW T15	FILW T22	KVA
TECHICAL DATA	Compliance emission 2002/88	Exempt	Exempt	Exempt	No	TECHICAL DATA
	Stand-by / Continuous [kVA]	6,2 / 5,8	9,5 / 9	15 / 13	22 / 20	
	Voltage [V] / Intensity [A] / Cos φ	400 / 8,9 / 0,8	400 / 13,7 / 0,8	400 / 21,5 / 0,8	400 / 31,5 / 0,8	
	Dimensions length x width x height [mm]	1200/560/830	1200/560/830	1800/740/1170	1800/740/1170	
	Dim packaging lengthxwidthxheight [mm]	1300/740/990	1300/740/990	1800/750/1230	1800/750/1230	
	Acoustic power LWA [dBA]	94	94	96	97	
	Acoustic pressure LPA [dBA] 16m/10m/7m/4m	62/66/69/74	62/66/69/74	64/68/71/76	65/69/72/77	
	Fuel tank [l] / Autonomy 75% (PRP) [h]	40 / 28	40 / 18	50 / 16	50 / 11	
Units per container 20' / 40'	24 / 56	24 / 56	9 / 19	9 / 19		
ENGINE	Engine code	1430-3376	2060	12537	12533	ENGINE
	Model	M430 FIMA	25LD330/O	LPW2/O	LPW3/O	
	Manufacturer	MINSEL	LOMBARDINI	LISTER	LISTER	
	Coupling	Cone Ø23mm	SAE5 7½	SAE5 7½	SAE5 7½	
	Cooling system / N° cylinders /Aspiration	Air/1/Natural	Air/2/Natural	Water/2/Natural	Water/3/Natural	
RC	Manual-Remote control RC	G5 FIMA T7 RC	G5 FIRA T10 RC	G5 FILW T15C1 RC	G5 FILW T22C1 RC	RC
	Generator code	3511	2246	2097	2098	
	Retail price	4.077 €	5.210 €	6.800 €	7.498 €	
Pricing	Net weight / With packaging [kg]	208 / 233	229 / 251	578 / 586	700 / 710	Pricing
	Alternator code	ALT-0012	13332	13947	13957	
ALT	Model	T100 SC	T100 LB	TR112 SC	TR112 MC	ALT
	Manufacturer	SACCARDO	SACCARDO	SACCARDO	SACCARDO	
	Regulation system	COMPOUND	COMPOUND	AVR	AVR	
	Protection index	IP23	IP23	IP23	IP23	
RC	Control panel type	Manual-Remote	Manual-Remote	Manual-Remote	Manual-Remote	RC
	CPU controller	GPMR72	GPMR72	GPMR72 + V	GPMR72 + V	
	Engine control panel / Engine wiring harness	3294/3125	2243/1945	14988/129	14988/129	
	Power control panel / Power wiring harness	3294/...187-112	2243/...187-112	3245/1729	1760/1711	
A	Automatic mains failure AMF	G5 FIMA T7 A	G5 FIRA T10 A	G5 FILW T15C1 A	G5 FILW T22C1 A	A
	Generator code	3381	2248	2104	2105	
	Retail price	4.301 €	5.494 €	6.937 €	7.627 €	
Pricing	Net weight / With packaging [kg]	215 / 239,8	229,4 / 250,3	577,6 / 586,2	700 / 710	Pricing
	Alternator code	1654	13866	13947	13957	
ALT	Model	TR100 SC	TR100 LB	TR112 SC	TR112 MC	ALT
	Manufacturer	SACCARDO	SACCARDO	SACCARDO	SACCARDO	
	Regulation system	AVR	AVR	AVR	AVR	
	Protection index	IP23	IP23	IP23	IP23	
AMF	Control panel type	Automatic AMF	Automatic AMF	Automatic AMF	Automatic AMF	AMF
	CPU controller	GECO + V	GECO + V	GECO + V	GECO + V	
	Engine control panel / Engine wiring harness	3300/225	2244/225	16745/129	16745/129	
	Power control panel / Power wiring harness	3300/89	2244/89	1747/1729	1730/1711	
KITS	Kit maint 1000 h ENGINE	1430-1150/54€	336-1051/90€	2x14589 / 108€	2x14591/114€	KITS
	Kit maint/emerg 1000 h ENGINE	1430-1152/82€	336-1020 / 146€	2280 / 134€	2281/141€	
	Kit maint/emerg 1000 h ALTERNATOR (NSM)	1882 / 27€	1882 / 27€	CONSULTAR	CONSULTAR	
Options	Available options (Code / Retail price)				Options	
ALT	AVR: NSM AVR (For "RC" models)	2167 / 162€	1000-5205 / 123€	SERIE	SERIE	ALT
	LSA: Leroy Somer alternator	N.A.	N.A.	N.A.	N.A.	
ATS	1ATS: Separated ATS for RC models	1976 / 170€	1976 / 170€	1976 / 170€	1976 / 170€	ATS
	2ATS: Integrated ATS for RC models	15185 / 95€	15185 / 95€	N.A.	N.A.	
	2ATS: Separated ATS for A models	1977 / 212€	1977 / 212€	1977 / 212€	1977 / 212€	
Panel	TEMP: Automatic start/stop clock for RC	3017 / 131€	3017 / 131€	3017 / 131€	3017 / 131€	Panel
	220V: 220V output for RC models	15389 / ASK	15389 / ASK	15393 / 58€	N.A.	
	220V: 220V output for A models	15390 / ASK	15390 / ASK	15394 / 42€	N.A.	
	GPM2: GM2 controller (A+V/A+F/V+F)	N.A.	N.A.	15142 / 138€	15142 / 138€	
	GPM3: GPM3 digital controller for RC models	N.A.	N.A.	14231 / 230€	14231 / 230€	
	GECO-MD: GECOMD digital for A models	N.A.	N.A.	14240 / 292€	14240 / 292€	
	AMF25: AMF25 digital for A with EMR	N.A.	N.A.	14184 / 453€	14184 / 453€	
	PROTDIF: Differential protection A models	15385 / 84€	15385 / 84€	15387 / 73€	15388 / 80€	
BASES: Shokets for RC models	SERIE	SERIE	15145 / 118€	15145 / 118€		
DESCBAT: Battery disconnecter	N.A.	N.A.	15345 / 85€	15345 / 85€		
Engine	VDO: Press & Pressure transmitt. (GPM3/AMF25)	N.A.	N.A.	15965 / 88€	15965 / 88€	Engine
	EMR: Engine electronic governor	N.A.	N.A.	N.A.	N.A.	
	AIRCALD: Air pre-heating for RC models	N.A.	N.A.	13095 / 80€	13095 / 80€	
	AIRCALD: Air pre-heating for A models	N.A.	N.A.	11777 / 165€	11777 / 165€	
	OILCALD: Oil pre-heating	3139 / 261€	18756 / 281€	N.A.	N.A.	
LIQCALD: Liquid pre-heating	N.A.	N.A.	13086 / 482€	13086 / 482€		
Inst	RESID: Residential muffler	SERIE	SERIE	SERIE	SERIE	Inst
	2,5FLEX50: 2,5m flexible tube for silencer	...934-032/55€	...934-032/55€	...934-032/55€	...934-032/55€	
	5FLEX50: 5m flexible tube for silencer	...934-033/93€	...934-033/93€	...934-033/93€	...934-033/93€	
Trailer	C.OBRA: Not aproved trailer	N.A.	N.A.	1AXLE / BALL 15518 / 920€	1AXLE / BALL 15518 / 920€	Trailer
	C.HOMOL: Aproved trailer (SPAIN)	N.A.	N.A.	1AXLE / BALL 15519 / 1700€	1AXLE / BALL 15519 / 1700€	
	C.ART: Articulated rod	N.A.	N.A.	Consult us	Consult us	
	C.ARG: Ring type coupling	N.A.	N.A.	Consult us	Consult us	
	RUEDAS: On skid wheels manual transport	Consult us	Consult us	N.D.	N.D.	
Fuel	DECCOMB: Fuel decanter	N.D.	N.D.	SERIE	SERIE	Fuel
	190L: Extra large 190L fuel tank	N.D.	N.D.	13493 / 273€	13493 / 273€	
	B-TR-MN: Semi-Automatic fuel electropump	N.D.	N.D.	N.D.	N.D.	
	B-TR-AU: Automatic fuel electropump	N.D.	N.D.	N.D.	N.D.	

1 ~



OPEN SKID generators = SINGLE-PHASE 3000 R.P.M.

G5 GENERATORS TARIF 50Hz						
F PROFESSIONAL 3000rpm 8h/día --- 800h/año ENGINE			A OPEN SKID			
M/R/L	M R L	Minsel Lombardini Lister-Petter	A/O/W		COOLING SYSTEM A W O Air Agua (Water) Aceite (Oil)	
RC Manual-Remote panel			A		Automatic AMF panel	

3000 RPM

50 HERTZ

KVA	Tecnical data	FAMA M6	FAMA M7	FAMA M8	FARA M9	FALW M13	KVA
TECHICAL DATA	Compliance emission 2002/88	Exempt	Exempt	Exempt	Exempt	Exempt	TECHICAL DATA
	Stand-by / Continuous [kVA]	5,5 / 5	7 / 6,7	8 / 7	8,5 / 7,7	13 / 11	
	Voltage [V] / Intensity [A] / Cos φ	230 / 24 / 0,9	230 / 30 / 0,9	230 / 34 / 0,9	230 / 37 / 0,9	230 / 56 / 0,9	
	Dimensions length x width x height [mm]	823/620/680	823/620/680	823 / 620 / 680	880 / 620 / 650	1450/750/1050	
	Dim packaging lengthxwidthxheight [mm]	850/680/790	850/680/790	850 / 680 / 790	940 / 840 / 850	1500/800/1230	
	Acoustic power LWA [dBA]	109	110	112	103	104	
	Acoustic pressure LPA [dBA] 16m/10m/7m/4m	77/81/84/89	78/82/85/90	80/84/87/92	71/75/78/83	72/76/79/84	
Fuel tank [l] / Autonomy 75% (PRP) [h]	18 / 12,5	18 / 9	18 / 7,8	18 / 8	30 / 10		
Units per container 20' / 40'	44 / 96	44 / 96	44 / 96	28 / 56	10 / 21		
ENGINE	Engine code	1430-5015	.224-4758	.226-4758	.336-0022	2085	ENGINE
	Model	M430	M540	M600	25LD330/O	LPW2/O	
	Manufacturer	MINSEL	MINSEL	MINSEL	LOMBARDINI	LISTER	
	Coupling	Cone Ø23mm	Cone Ø30mm	Cone Ø30mm	Cone Ø30mm	SAE5 7½	
	Cooling system / N° cylinders /Aspiration	Air/1/Natural	Air/1/Natural	Air/1/Natural	Air/2/Natural	Water/2/Natural	
RC	Manual-Remote control RC	G5 FAMA M6 RC	G5 FAMA M7 RC	G5 FAMA M8 RC	G5 FARA M9 RC	G5 FALW M13 RC	RC
	Generator code	G6D0109	G6D0257	N.D.	G6D0092	2701	
	Retail price	2.293 €	2.618 €	N.D.	3.425 €	5.203 €	
ALT	Generator code	134 / 144	141 / 151	141 / 151	144 / 160	400 / 415	ALT
	Alternator code	14793	ALT-0076	ALT-0076	ALT-0076	13957	
	Model	SE100FX	M100LL	M100LL	M100LL	TR112 MC	
	Manufacturer	SACCARDO	SACCARDO	SACCARDO	SACCARDO	SACCARDO	
	Regulation system	CONDENS	CONDENS	CONDENS	CONDENS	AVR	
RC	Protection index	IP21	IP23	IP23	IP23	IP23	RC
	Control panel type	Manual-Remote	Manual-Remote	Manual-Remote	Manual-Remote	Manual-Remote	
	CPU controller	GPMR72 + V	GPMR72 + V	GPMR72 + V	GPMR72 + V	GPMR72 + V	
	Engine control panel / Engine wiring harness	.224-1034/-	.224-1034/-	.224-1034/-	.224-1034/-	14988/129	
	Power control panel / Power wiring harness	.224-1034/-	.224-1034/-	.224-1034/-	.224-1034/-	2545/890	
A	Automatic mains failure AMF	G5 FAMA M6 A	G5 FAMA M7 A	G5 FAMA M8 A	G5 FARA M9 A	G5 FALW M13 A	A
	Generator code	G6D0154	G6D0179	G6D0209	G6D0290	2791	
	Retail price	2.712 €	3.080 €	3.157 €	3.892 €	5.194 €	
ALT	Generator code	135 / 145,1	142 / 152,1	143 / 152,1	143 / 158,7	400 / 415	ALT
	Alternator code	1637	1638	1638	1638	13957	
	Model	MR100 SF	MR100 LL	MR100 LL	MR100 LL	TR112 MC	
	Manufacturer	SACCARDO	SACCARDO	SACCARDO	SACCARDO	SACCARDO	
	Regulation system	AVR	AVR	AVR	AVR	AVR	
AMF	Protection index	IP23	IP23	IP23	IP23	IP23	AMF
	Control panel type	Automatic AMF	Automatic AMF	Automatic AMF	Automatic AMF	Automatic AMF	
	CPU controller	GECO + V	GECO + V	GECO + V	GECO + V	GECO + V	
	Engine control panel / Engine wiring harness	...805-017/88	...805-017/88	...805-017/88	...805-017/88	1689/129	
	Power control panel / Power wiring harness	...805-017/...187-408	...805-017/...187-408	...805-017/...187-408	...805-017/...187-408	2581/890	
KITS	Kit mant 1000 ENGINE	1430-1150/54€	1430-1150/54€	1430-1150/54€	.336-1051/90€	2276/108€	KITS
	Kit maint/emerg 1000 horas MOTOR	1430-1152/82€	1430-1152/82€	1430-1152/82€	.336-1020/146€	2280/134€	
	Kit maint/emerg 1000 h ALTERNATOR (SE100)	1884 / 31€	-	-	-	-	
	Kit maint/emerg 1000 h ALTERNATOR (M100)	Consult us	Consult us	Consult us	Consult us	Consult us	
Option	Available options (Code / Retail price)						Option
ALT	AVR: NSM AVR (For "RC" models)	2156 / 151€	2141 / 195€	NO RC	2141 / 195€	SERIE	ALT
	LSA: Leroy Somer alternator	N.A.	N.A.	N.A.	N.A.	N.A.	
	1ATS: Separated ATS for RC models	15925 / 170€	15925 / 170€	15925 / 170€	15925 / 170€	15925 / 170€	
ATS	2ATS: Integrated ATS for RC models	15184 / 104€	15184 / 104€	15184 / 104€	15184 / 104€	N.A.	ATS
	2ATS: Separated ATS for A models	15928 / 212€	15928 / 212€	15928 / 212€	15928 / 212€	15928 / 212€	
	TEMP: Automatic start/stop clock for RC	3017 / 131€	3017 / 131€	3017 / 131€	3017 / 131€	3017 / 131€	
Panel	GPM2: GM2 controller (A+V/A+F/V+F)	N.A.	N.A.	N.A.	N.A.	N.A.	Panel
	GPM3: GPM3 digital controller for RC models	N.A.	N.A.	N.A.	N.A.	14231 / 230€	
	GECO-MD: GECOMD digital for A models	N.A.	N.A.	N.A.	N.A.	14240 / 292€	
	AMF25: AMF25 digital for A with EMR	N.A.	N.A.	N.A.	N.A.	14184 / 453€	
	PROTDIF: Differential protection A models	15382 / 16€	15382 / 16€	15382 / 16€	15382 / 16€	15384 / 118€	
	BASES: Shokets for RC models	SERIE	SERIE	SERIE	SERIE	N.A.	
	DESCBAT: Battery disconnecter	Consult us	Consult us	Consult us	Consult us	15345 / 88€	
Engine	VDO: Press & Pressure transmitt. (GPM3/AMF25)	N.A.	N.A.	N.A.	N.A.	15965 / 88€	Engine
	EMR: Engine electronic governor	N.A.	N.A.	N.A.	N.A.	N.A.	
	AIRCALD: Air pre-heating for RC models	N.A.	N.A.	N.A.	N.A.	13095 / 80€	
	AIRCALD: Air pre-heating for A models	N.A.	N.A.	N.A.	N.A.	11777 / 165€	
	OILCALD: Oil pre-heating	3139 / 261€	3139 / 261€	3139 / 261€	3139 / 261€	N.A.	
	LIQCALD: Liquid pre-heating	N.A.	N.A.	N.A.	N.A.	13086 / 482€	
Inst	RESID: Residential muffler	N.A.	N.A.	N.A.	N.A.	15284 / 198€	Inst
	2,5FLEX50: 2,5m flexible tube for silencer	...934-032/55€	...934-032/55€	...934-032/55€	...934-032/55€	...934-032/55€	
	5FLEX50: 5m flexible tube for silencer	...934-033/93€	...934-033/93€	...934-033/93€	...934-033/93€	...934-033/93€	
Trailer	C.OBRA: Not approved trailer	1430-1132/72€	1430-1132/72€	1430-1132/72€	.336-1037/89€	N.A.	Trailer
	C.HOMOL: Aproved trailer (SPAIN)	N.A.	N.A.	N.A.	N.A.	1 Axle / Ball 3138 / 869€	
	C.ART: Articulated rod	N.A.	N.A.	N.A.	N.A.	Consult us	
	C.ARG: Ring type coupling	N.A.	N.A.	N.A.	N.A.	15335 / 40€	
Fuel	DECCOMB: Fuel decanter	N.A.	N.A.	N.A.	N.A.	SERIE	Fuel
	190L: Extra large 190L fuel tank	N.A.	N.A.	N.A.	N.A.	18082 / 391€	
	B-TR-MN: Semi-Automatic fuel electropump	N.A.	N.A.	N.A.	N.A.	Consult us	
	B-TR-AU: Automatic fuel electropump	N.A.	N.A.	N.A.	N.A.	Consult us	

3 ~



OPEN SKID GENERATORS = THREE-PHASE 3000 R.P.M.

3000 RPM

50 HERTZ

GENERATORS TARIF 50HZ							
G5	PROFESSIONAL ENGINE			OPEN SKID GENERATOR			
F	3000rpm 8h/día --- 800h/año			A			
M/R/L	M R L	Minsel Lombardini Lister-Petter	A/O/W		A W O	Air Agua (Water) Aceite (Oil)	
RC	Manual-Remote panel			A Automatic AMF panel			

KVA	Tecnical data	FAMA T7	FAMA T8	FAMA T9	FARA T10	FALW T15	FALW T22	KVA
TECHNICAL DATA	Compliance emission 2002/88	Exempt	Exempt	Exempt	Exempt	Exempt	No	TECHNICAL DATA
	Stand-by / Continuous [kVA]	6,2 / 5,8	8 / 7,5	9 / 8	9,5 / 9	15 / 13	22 / 20	
	Voltage [V] / Intensity [A] / Cos φ	400 / 8,9 / 0,8	400 / 11,5 / 0,8	400 / 13 / 0,8	400 / 13,7 / 0,8	400 / 21,5 / 0,8	400 / 31,5 / 0,8	
	Dimensions length x width x height [mm]	823/620/680	823/620/680	823 / 620 / 680	880 / 620 / 650	1450/750/1050	1450/750/1050	
	Dim packaging lengthxwidthxheight [mm]	850/680/790	850/680/790	850 / 680 / 790	940 / 840 / 850	1500/800/1230	1500/800/1230	
	Acoustic power LWA [dBA]	109	110	112	103	104	103	
	Acoustic pressure LPA [dBA] 16m/10m/7m/4m	77/81/84/89	78/82/85/90	80/84/87/92	71/75/78/83	72/76/79/84	71/75/78/83	
	Fuel tank [l] / Autonomy 75% (PRP) [h]	18 / 12,5	18 / 9	18 / 7,8	18 / 8	30 / 10	30 / 7	
Units per container 20' / 40'	44 / 96	44 / 96	44 / 96	28 / 56	10 / 21	10 / 21		
ENGINE	Engine code	1430-5015	.224-4758	226-4758	.336-0022	2085	2087	ENGINE
	Model	M430	M540	M600	25LD330/O	LPW2/O	LPW3/O	
	Manufacturer	MINSEL	MINSEL	MINSEL	LOMBARDINI	LISTER	LISTER	
	Coupling	Cono Ø23mm	Cono Ø30mm	Cono Ø30mm	Cono Ø30mm	SAE5 7½	SAE5 7½	
	Cooling system / N° cylinders /Aspiration	Air/1/Natural	Air/1/Natural	Air/1/Natural	Water/2/Natural	Water/2/Natural	Water/3/Natural	
RC	Manual-Remote control RC	G5 FAMA T7 RC	G5 FAMA T8 RC	G5 FAMA T9 RC	G5 FARA T10 RC	G5 FALW T15 RC	G5 FALW T22 RC	RC
	Generator code	GED0256	GED0258	N.D.	GED0105	3020	2092	
Pricing	Retail price	2.534 €	2.803 €		3.612 €	5.041 €	5.687 €	Pricing
	Net weight / With packaging [kg]	130 / 140	147 / 157		153 / 169	400 / 415	450 / 459	
ALT	Alternator code	ALT-0012	13332		13332	13947	13957	ALT
	Model	T100SC	T100 LB		T100 LB	TR112 SC	TR112 MC	
	Manufacturer	SACCARDO	SACCARDO		SACCARDO	SACCARDO	SACCARDO	
	Regulation system	COMPOUND	COMPOUND		COMPOUND	AVR	AVR	
	Protection index	IP23	IP23		IP23	IP23	IP23	
RC	Control panel type	Manual-Remote	Manual-Remote		Manual-Remote	Manual-Remote	Manual-Remote	RC
	CPU controller	GPMR72 + V	GPMR72 + V		GPMR72 + V	GPMR72 + V	GPMR72 + V	
	Engine control panel / Engine wiring harness	.336-1023/-	.336-1023/-		.336-1023/-	14988/129	14988/129	
	Power control panel / Power wiring harness	.336-1023/-	.336-1023/-		.336-1023/-	3245/1729	1760/1711	
A	Automatic mains failure AMF	G5 FAMA T7 A	G5 FAMA T8 A	G5 FAMA T9 A	G5 FARA T10 A	G5 FALW T15 A	G5 FALW T22 A	A
	Generator code	GED0042	GED0022	GED0168	GED0028	3253	2140	
Pricing	Retail price	2.994 €	3.225 €	3.302 €	4.038 €	5.127 €	5.816 €	PVP
	Net weight / With packaging [kg]	133 / 143	150 / 160	155 / 165	160 / 176	400 / 415	450 / 459	
ALT	Alternator code	1654	13866	13866	13866	13947	13957	ALT
	Model	TR100SC	TR100LB	TR100LB	TR100LB	TR112 SC	TR112 MC	
	Manufacturer	SACCARDO	SACCARDO	SACCARDO	SACCARDO	SACCARDO	SACCARDO	
	Regulation system	AVR	AVR	AVR	AVR	AVR	AVR	
	Protection index	IP23	IP23	IP23	IP23	IP23	IP23	
AMF	Control panel type	Automatic AMF	Automatic AMF	Automatic AMF	Automatic AMF	Automatic AMF	Automatic AMF	AMF
	CPU controller	GECO + V	GECO + V	GECO + V	GECO + V	GECO + V	GECO + V	
	Engine control panel / Engine wiring harness	...805-024/88	...805-024/88	...805-024/88	...805-024/88	16745/129	16745/129	
	Power control panel / Power wiring harness	...805-024/89	...805-024/89	...805-024/89	...805-024/89	1747/1729	1730/1711	
KITS	Kit mant 1000 horas MOTOR	1430-1150 / 54€	1430-1150 / 54€	1430-1150 / 54€	.336-1051 / 90€	2276 / 108€	22278 / 116€	KITS
	Kit mant/emerg 1000 horas MOTOR	1430-1152 / 82€	1430-1152 / 82€	1430-1152 / 82€	.336-1020 / 146€	2280 / 134€	2281 / 141€	
	Kit mant/emerg 1000 h ALTERNADOR (SACCARDO)	1882 / 27€	1882 / 27€	1882 / 27€	1882 / 27€	CONSULTAR	CONSULTAR	
Options	Available options (Code/Retail price)							Options
ALT	AVR: NSM AVR (For "RC" models)	2167 / 162€	1000-5205/123€	NO RC model	1000-5205/123€	SERIE	SERIE	ALT
	LSA: Leroy Somer alternator	N.A.	N.A.	N.A.	N.A.	N.A.	N.A.	
ATS	1ATS: Separated ATS for RC models	1976 / 170€	1976 / 170€	1976 / 170€	1976 / 170€	1976 / 170€	1976 / 170€	ATS
	2ATS: Integrated ATS for RC models	15185 / 95€	15185 / 95€	15185 / 95€	15185 / 95€	N.A.	N.A.	
	2ATS: Separated ATS for A models	1977 / 212€	1977 / 212€	1977 / 212€	1977 / 212€	1977 / 212€	1977 / 212€	
Panel	220V: Output 220V for RC models	15389 / 50€	15389 / 50€	15389 / 50€	15389 / 50€	15393 / 58€	N.D.	Panel
	220V: Output 220V for A models	15390 / ASK	15390 / ASK	15390 / ASK	15390 / ASK	15394 / 42€	N.D.	
	TEMP: Automatic start/stop clock for RC	3017 / 131€	3017 / 131€	3017 / 131€	3017 / 131€	3017 / 131€	3017 / 131€	
	GPM2: GM2 controller (A+V/A+V+F)	N.A.	N.A.	N.A.	N.A.	N.A.	N.A.	
	GPM3: GPM3 digital controller for RC models	N.A.	N.A.	N.A.	N.A.	14231 / 230€	14231 / 230€	
	GECO-MD: GECOMD digital for A models	N.A.	N.A.	N.A.	N.A.	14240 / 292€	14240 / 292€	
	AMF25: AMF25 digital for A with EMR	N.A.	N.A.	N.A.	N.A.	14184 / 453€	14184 / 453€	
	PROTDIF: Differential protection A models	15385 / 84€	15385 / 84€	15385 / 84€	15385 / 84€	15387 / 73€	15388 / 80€	
	BASES: Shokets for RC models	SERIE	SERIE	SERIE	SERIE	N.A.	N.A.	
	DESCBAT: Battery disconnecter	Consult us	Consult us	Consult us	Consult us	15345 / 88€	15345 / 88€	
Engine	VDO: Press & Pressure transmitt. (GPM3/AMF25)	N.A.	N.A.	N.A.	N.A.	15965 / 88€	15965 / 88€	Engine
	EMR: Engine electronic governor	N.A.	N.A.	N.A.	N.A.	N.A.	N.A.	
	AIRCALD: Air pre-heating for RC models	N.A.	N.A.	N.A.	N.A.	13095 / 80€	13095 / 80€	
	AIRCALD: Air pre-heating for A models	N.A.	N.A.	N.A.	N.A.	11777 / 165€	11777 / 165€	
	OILCALD: Oil pre-heating	3139 / 261€	3139 / 261€	3139 / 261€	3139 / 261€	N.A.	N.A.	
Inst	LIQCALD: Liquid pre-heating	N.A.	N.A.	N.A.	N.A.	13086 / 482€	13086 / 482€	Inst
	RESID: Residential muffler	N.A.	N.A.	N.A.	N.A.	15284 / 198€	15284 / 198€	
	2,5FLEX50: 2,5m flexible tube for silencer	...934-032/55€	...934-032/55€	...934-032/55€	...934-032/55€	...934-032/55€	...934-032/55€	
Trailer	5FLEX50: 5m flexible tube for silencer	...934-033/93€	...934-033/93€	...934-033/93€	...934-033/93€	...934-033/93€	...934-033/93€	Trailer
	RUEDAS: On skid wheels for manual transport	1430-1132/72€	1430-1132/72€	1430-1132/72€	.336-1037/88€	N.A.	N.A.	
	C.OBRA: Not approved trailer option	N.A.	N.A.	N.A.	N.A.	1 Axle / Ball	1 Axle / Ball	
Fuel	C.ART: Articulated rod	N.A.	N.A.	N.A.	N.A.	3138 / 869€	3138 / 869€	Fuel
	C.ARG: Ring type coupling	N.A.	N.A.	N.A.	N.A.	Consult us	Consult us	
	DECCOMB: Fuel decanter	N.A.	N.A.	N.A.	N.A.	15335 / 40€	15335 / 40€	
	190L: Extra large 190L fuel tank	N.A.	N.A.	N.A.	N.A.	SERIE	SERIE	
Fuel	B-TR-MN: Semi-Automatic fuel electropump	N.A.	N.A.	N.A.	N.A.	18082 / 391€	18082 / 391€	Fuel
	B-TR-AU: Automatic fuel electropump	N.A.	N.A.	N.A.	N.A.	15432 / 500€	15432 / 500€	

Open skid generators 1500rpm - 24h/day - 2000h/year



OPEN SKID GENERATORS 1500rpm - 24h/day - 2000h/year



OPEN SKID GENERATORS - SINGLE-PHASE 1500rpm						
G5			GENERATORS TARIF 50Hz			
C	CONTINUOUS 1500rpm 24h/día --- 2000h/año			A	OPEN SKID	
R/L/D	ENGINE			COOLING SYSTEM		
	D	Deutz	A/W	A	Aire	
	R	Lombardini		W	Agua (Water)	
	L	Lister-Petter				
RC	Manual-Remote panel			A	Automatic AMF panel	

50
HERTZ

1500
RPM

KVA	Technical data	CADA M13	CADA M21	CALW M31	CADA M31	CADA M42	KVA
TECHNICAL DATA	Compliance emission 2002/88	YES	YES	NO	YES	YES	TECHNICAL DATA
	Stand-by power/Continuous power [KVA]	13 / 11	20,6 / 18,5	30,6 / 28	30,6 / 28	42 / 38	
	Voltage [V] / Intensity [A] / Cos φ	230 / 56 / 0,9	230 / 90 / 0,9	230 / 133 / 0,9	230 / 133 / 0,9	230 / 182 / 0,9	
	Dimensions length x width x height [mm]	1450/750/1010	1450/750/1100	1630/850/1150	1630/850/1150	1630/850/1160	
	Dim packaging length x width x height [mm]	1500/800/1230	1500/800/1230	1700/940/1230	1700/940/1230	1700/940/1230	
	Acoustic power LWA [dBA]	99	100	CONSULTAR	103	97	
	Acoustic pressure LPA [dBA] 16m/10m/7m/4m	67/71/74/79	68/72/75/80	CONSULTAR	71/75/78/83	65/69/72/77	
	Fuel tank [l] / Autonomy 75% (PRP) [h]	30 / 12	30 / 8	60 / 10	60 / 11	60 / 8	
Units per container 20' / 40'	10 / 21	10 / 21	6 / 14	6 / 14	6 / 14		
ENGINE	Engine code	171	197	14961	199	201	ENGINE
	Model	F2L2011/8	F3L2011/8	DWS4-03/8	F4L2011/8	BF4L2011/8	
	Manufacturer	DEUTZ	DEUTZ	LISTER	DEUTZ	DEUTZ	
	Coupling	SAE3 11½	SAE3 11½	SAE3 11½	SAE3 11½	SAE3 11½	
	Cooling system / N° cilindres /Aspiration	Air/2/Natural	Air/3/Natural	Water/4/Natural	Air/4/Natural	Air/4/Turbo	
ALT	Alternator code	18808	1151	1134	1134	642	ALT
	Model	LSA 40 L7	LSA 42.2 L9	LSA43.2S15	LSA43.2S15	LSA43.2M45	
	Manufacturer	LEROY SOMER	LEROY SOMER	LEROY SOMER	LEROY SOMER	LEROY SOMER	
	Regulation	AVR	AVR	AVR	AVR	AVR	
	Protection index	IP23	IP23	IP23	IP23	IP23	
RC	Remote - CEE	G5 CADA	G5 CADA	G5 CALW	G5 CADA	G5 CADA	RC
		M13 RC	M21 RC	M31 RC	M31 RC	M42 RC	
Pricing	Generator code	420	2736	15191	871	12473	Pricing
	Retail price	6.850 €	7.820 €	8.738 €	8.599 €	9.791 €	
	Net weight / With packaging [kg]	491 / 500	530 / 539	635 / 643	645 / 654	748 / 760	
RC	Control panel type	Manual-Remote	Manual-Remote	Manual-Remote	Manual-Remote	Manual-Remote	RC
	Controller CPU	GPMR72 + V	GPMR72 + V	GPMR72 + V	GPMR72 + V	GPMR72 + V	
	Engine panel / Engine wiring harness	14988/226	14988/226	14988/129	14988/226	14988/226	
	Power control panel / Power wiring harness	2545/544	2 / 544	2641/440	2641/440	11878/440	
A	Automático / Caída de red	G5 CADA	G5 CADA	G5 CALW	G5 CADA	G5 CADA	A
		M13 A	M21 A	M31 A	M31 A	M42 A	
Pricing	Generator code	798	2739	15192	15053	3606	Pricing
	Retail price	6.830 €	7.776 €	8.698 €	8.560 €	9.747 €	
	Net weight / With packaging [kg]	490,9 / 499,6	529,9 / 538,6	635 / 643	644,9 / 653,6	748 / 760	
AMF	Control panel type	Automatic AMF	Automatic AMF	Automatic AMF	Automatic AMF	Automatic AMF	AMF
	Controller CPU	GECO + V	GECO + V	GECO + V	GECO + V	GECO + V	
	Engine panel / Engine wiring harness	1689/226	1689/226	1689/129	1689/226	1689/226	
	Power control panel / Power wiring harness	2581/544	797/544	2642/440	2642/440	11879/440	
KITS	Kit mant 1000 h ENGINE	DEU-1080/ 58€	DEU-1080/ 58€	657-76130/ 280€	DEU-1080/ 58€	DEU-1090/ 112€	KITS
	Kit mant/emerg 1000 h ENGINE	DEU-1093/ 77€	DEU-1093/ 77€	15527 / 358€	DEU-1093/ 77€	DEU-1109/ 136€	
	Kit mant/emerg 1000 h ALTERNATOR (NSM)	-	-	-	-	-	
Options	Available options (Code / Retail price)						Options
ALT	AVR: NSM AVR alternator	SERIE	SERIE	SERIE	SERIE	SERIE	ALT
	LSA: Leroy Somer alternator	SERIE	SERIE	SERIE	SERIE	SERIE	
	LSA-TR: Leroy Somer tropicalized	XXXX / 271€	14175 / 271€	14176 / 271€	14176 / 271€	12419 / 265€	
	LSA-PMG: Leroy Somer PMG system	Consult us	Consult us	Consult us	Consult us	Consult us	
	LSACALD: Leroy Somer with preheating	XXXX / 203€	14251 / 162€	15153 / 215€	15153 / 215€	15489 / 215€	
ATS	1ATS: Integrated ATS for RC models	N.A.	N.A.	N.A.	N.A.	N.A.	ATS
	1ATS: Separated ATS for RC models	15926 / 294€	15926 / 294€	15926 / 294€	15926 / 294€	15927 / 477€	
	2ATS: Separated ATS for A models	15929 / 479€	15929 / 479€	15929 / 479€	15929 / 479€	15930 / 920€	
Panel	TEMP: Automatic start/stop clock for RC	3017 / 131€	3017 / 131€	3017 / 131€	3017 / 131€	3017 / 131€	Panel
	GPM2: GM2 controller (A+V/A+F/V+F)	N.A.	N.A.	N.A.	N.A.	N.A.	
	GPM3: GPM3 digital controller for RC models	14231 / 230€	14231 / 230€	14231 / 230€	14231 / 230€	14231 / 230€	
	GECO-MD: GECOMD digital for A models	14240 / 292€	14240 / 292€	14240 / 292€	14240 / 292€	14240 / 292€	
	AMF25: AMF25 digital for A with EMR	15023 / 161€	14184 / 453€	14184 / 453€	14184 / 453€	14184 / 453€	
	PROTDIF: Differential protection A models	15407 / 118€	15409 / 154€	15434 / 149€	15434 / 149€	15435 / 187€	
	BASES: Shokets for RC models	N.A.	N.A.	N.A.	N.A.	N.A.	
	DESCBAT: Battery disconnecter	15345 / 88€	15345 / 88€	15345 / 88€	15345 / 88€	15345 / 88€	
Engine	VDO: Press & Temp transmitt. (GPM3/AMF25)	15967 / 130€	15967 / 130€	15967 / 130€	15967 / 130€	15967 / 130€	Engine
	EMR-A: Engine electronic governor for A	15276 / 1102€	15277 / 1102€	N.D.	15288 / 1102€	15288 / 1102€	
	EMR-RC: Engine electronic governor for RC	15269 / 810€	15271 / 810€	N.D.	15022 / 810€	15022 / 810€	
	EMR-BUS: Engine MODBUS (needs AMF25)	15349 / 325€	15349 / 325€	15349 / 325€	15349 / 325€	15349 / 325€	
	AIRCALD: Air pre-heating for RC models	13098 / 155€	13098 / 155€	13098 / 155€	13098 / 155€	13098 / 155€	
	AIRCALD: Air pre-heating for A models	13041 / 243€	13041 / 243€	13041 / 243€	13041 / 243€	13041 / 243€	
	OILCALD: Oil pre-heating	N.A.	N.A.	N.A.	N.A.	N.A.	
	LIQCALD: Liquid pre-heating	N.A.	N.A.	N.A.	N.A.	N.A.	
Inst	RESID: Residential muffler	3465 / 198€	3465 / 198€	15284 / 198€	3465 / 198€	3465 / 198€	Inst
	2,5FLEX50: 2,5m flexible tube for silencer	...934-032 / 55€	...934-032 / 55€	...934-032 / 55€	...934-032 / 55€	...934-032 / 55€	
	5FLEX50: 5m flexible tube for silencer	...934-033 / 93€	...934-033 / 93€	...934-033 / 93€	...934-033 / 93€	...934-033 / 93€	
Trailer	C.OBRA: Not aproved trailer	3138 / 947€	3138 / 947€	3488 / 1.062€	3488 / 1.062€	3488 / 1.062€	Trailer
	C.ART: Articulated rod	Consult us	Consult us	Consult us	Consult us	Consult us	
	C.ARG: Ring type coupling	15335 / 42€	15335 / 42€	15335 / 40€	15335 / 40€	15335 / 40€	
Fuel	DECCOMB: Fuel decanter	18083 / 391€	18083 / 391€	SERIE	15970 / 350€	15970 / 350€	Fuel
	190L: Extra large 190L fuel tank	15970 / 361€	15970 / 361€	N.A.	17162 / 391€	17162 / 391€	
	B-TR-MN: Semi-Automatic fuel electropump	15432 / 500€	15432 / 500€	15432 / 500€	15432 / 500€	15432 / 500€	
	B-TR-AU: Automatic fuel electropump	15433 / 542€	15433 / 542€	15433 / 542€	15433 / 542€	15433 / 542€	



OPEN SKID GENERATORS = THREE-PHASE 1500R.P.M.



G5	GENRATORS TARIF 50Hz	
C	CONTINUOUS	A
M/R	1500rpm 24h/day --- 2000h/year	OPEN SKID GENERATORS
L/D	M Minsel R Lombardini D Deutz L Lister-Petter	A/W
RC	Manual-Remote panel	A
		Automatic AMF panel
		COOLING SYSTEM
		A Aire W Agua (Water)

KVA	Technical data	CAMA T6	CARA T7	CALW T10	CARA T10	CALW T15	CADA T15	KVA
TECHNICAL DATA	Compliance emission 2002/88	Exempt	Exempt	Exempt	Exempt	Exempt	YES	TECHNICAL DATA
	Stand-by power/Continuous power [kVA]	5,5 / 4,7	7 / 6,3	10 / 9	10 / 9	14 / 13	14 / 13	
	Voltage [V] / Intensity [A] / Cos φ	400 / 8 / 0,8	400 / 10 / 0,8	400 / 14 / 0,8	400 / 14 / 0,8	400 / 20 / 0,8	400 / 20 / 0,8	
	Dimensions length x width x height [mm]	1200/656/880	1200/656/930	1450/750/1050	1250/656/920	1450/750/1050	1450/750/1010	
	Dim packaging length x width x height [mm]	1300/720/950	1300/720/950	1500/800/1230	1300/720/950	1500/800/1230	1500/800/1230	
	Acoustic power LWA [dBA]	111	N.D.	98	99	98	99	
	Acoustic pressure LPA [dBA] 16m/10m/7m/4m	79/83/86/91	N.D.	66/70/73/78	67/71/74/79	66/70/73/78	67/71/74/79	
Fuel tank [l] / Autonomy 75% (PRP) [h]	25 / 21	25 / 20	30 / 20	30 / 14	30 / 14	30 / 12		
Units per container 20' / 40'	12 / 27	12 / 27	10 / 21	12 / 27	10 / 21	10 / 21		
ENGINE	Engine code	.241-5007	13033	1348	1298-0005	1434	171	ENGINE
	Model	M608	4LD820	LPW2	9LD625	LPW3	F2L2011	
	Manufacturer	MINSEL	LOMBARDINI	LISTER	LOMBARDINI	LISTER	DEUTZ	
	Coupling	Cone Ø30mm	Cone Ø30mm	SAE5 7½	SAE4 7½	SAE5 7½	SAE3 11½	
	Cooling system / N° cylindres /Aspiration	Air/1/Natural	Air/1/Natural	Water/2/Natural	Air/2/Natural	Water/3/Natural	Air/2/Natural	
RC	Manual-Remote panel	G5 CAMA	G5 CARA	G5 CALW	G5 CARA	G5 CALW	G5 CADA	RC
		T6 RC	T7 RC	T10 RC	T10 RC	T15 RC	T15 RC	
	Generator code	G6D0095	13038	2839	G6D0101	3002	G6D0521	
Pricing	Retail price	3.659 €	4.232 €	4.919 €	4.897 €	5.500 €	5.917 €	Pricing
	Net weight / With packaging [kg]	219 / 227	266 / 274	394 / 402	314 / 322	443 / 452	448 / 457	
	Alternator code	1639	1639	15010	13105	14828	14854	
ALT	Model	T132 XSA	T132 XSA	T132 XSB	T132 XSB	T132 SA	T132 SA	ALT
	Manufacturer	SACCARDO	SACCARDO	SACCARDO	SACCARDO	SACCARDO	SACCARDO	
	Regulation	COMPOUND	COMPOUND	COMPOUND	COMPOUND	COMPOUND	COMPOUND	
	Protection index	IP20	IP20	IP23	IP23	IP23	IP23	
	Control panel type	Manual-Remote	Manual-Remote	Manual-Remote	Manual-Remote	Manual-Remote	Manual-Remote	
RC	Controller CPU	GPMR72 + V	GPMR72 + V	GPMR72 + V	GPMR72 + V	GPMR72 + V	GPMR72 + V	RC
	Engine panel / Engine wiring harness	14988/3116	14988/13148	14988/129	14988/129	14988/129	14988/226	
	Power control panel / Power wiring harness	14785/1711	14785/1711	14785/1711	14785/1711	3245/1711	3245/1711	
A	Automatic AMF panel	G5 CAMA	G5 CARA	G5 CALW T10	G5 CARA	G5 CALW	G5 CADA	A
		T6 A	T7 A	A	T10 A	T15 A	T15 A	
	Generator code	N.A.	N.A.	2842	See page 19	3069	G6D0561	
Pricing	Retail price			5.350 €		5.957 €	6.496 €	Pricing
	Net weight / With packaging [kg]			396 / 405		448 / 457	465 / 480	
	Alternator code			18805		18798	18807	
ALT	Model			LSA 40 VS1		LSA 40 VS2	LSA 40 VS2	ALT
	Manufacturer			LEROY SOMER		LEROY SOMER	LEROY SOMER	
	Regulation			AVR		AVR	AVR	
	Protection index			IP23		IP23	IP23	
	Control panel type			Automatic AMF		Automatic AMF	Automatic AMF	
AMF	Controller CPU			GECO + VI6		GECO + VI6	GECO + VI6	AMF
	Engine panel / Engine wiring harness			16745 / 129		16745 / 129	16745 / 226	
	Power control panel / Power wiring harness			16214 / 1711		3245 / 1711	3245 / 1711	
KITS	Kit maint 1000 h Engine	1430-1150/54€	13327 / 102€	2276 / 108€	3494 / 123€	2278 / 116€	DEU-1080/58€	KITS
	Kit maint/emerg 1000 h Engine	1430-1152/82€	13328 / 145€	2277 / 143€	3497 / 209€	2279 / 143€	DEU-1093/77€	
	Kit maint/emerg 1000 h ALT (T132)	1893 / 118€	1893 / 118€	-	1893 / 118€	1893 / 118€	1893 / 118€	
Options	Available options (Code / Retail price)							Options
ALT	AVR: NSM AVR alternator for "RC" models	N.A.	N.A.	15130 / 345€	N.A.	15070 / 415€	N.A.	ALT
	LSA: Leroy Somer alternator for "A" models	N.A.	N.A.	SERIE	Page 19	SERIE	15543 / 330€	
	LSA-TR: Leroy Somer tropicalized	N.A.	N.A.	XXXXX / 265€	Page 19	XXXXX / 265€	XXXXX / 265€	
	LSA-PMG: Leroy Somer PMG system	N.A.	N.A.	Consult us	Consult us	Consult us	Consult us	
	LSACALD: Leroy Somer with preheating	N.A.	N.A.	XXXXX / 215€	Page 19	XXXXX / 215€	XXXXX / 215€	
ATS	1ATS: Integrated ATS for RC models	N.A.	N.A.	N.A.	N.A.	N.A.	N.A.	ATS
	1ATS: Separated ATS for RC models	1976 / 170€	1976 / 170€	1976 / 170€	1976 / 170€	1976 / 170€	1976 / 170€	
	2ATS: Separated ATS for A models	N.A.	N.A.	1977 / 212€	1977 / 212€	1977 / 212€	1977 / 212€	
Panel	TEMP: Automatic start/stop clock for RC	3017 / 131€	3017 / 131€	3017 / 131€	3017 / 131€	3017 / 131€	3017 / 131€	Panel
	220V: Output 220V voltage for RC models	Consult us	Consult us	Page 19	Page 19	Page 19	15393 / 58 €	
	220V: Output 220V voltage for A models	Consult us	Consult us	Page 19	Page 19	Page 19	15394 / 42 €	
	GPM2: GM2 controller (A+V/A+F/V+F)	N.A.	N.A.	N.A.	N.A.	N.A.	N.A.	
	GPM3: GPM3 digital controller for RC models	N.A.	N.A.	14231 / 230 €	N.A.	14231 / 230 €	14231 / 230 €	
	GECO-MD: GECOMD digital for A models	N.A.	N.A.	14240 / 292 €	Page 19	14240 / 292 €	14240 / 292 €	
	AMF25: AMF25 digital for A with EMR	N.A.	N.A.	14184 / 453 €	N.A.	14184 / 453 €	14184 / 453 €	
	PROTDIF: Differential protection A models	N.A.	N.A.	15437 / 76€	15437 / 76€	15438 / 76€	15438 / 76€	
	BASES: Shokets for RC models	SERIE	SERIE	SERIE	SERIE	N.A.	N.A.	
	DESCBAT: Battery disconnecter	15345 / 88€	15345 / 88€	15345 / 88€	15345 / 88€	15345 / 88€	15345 / 88€	
Engine	VDO: Press & Temp transmitt. (GPM3/AMF25)	1337 / 97€	1337 / 97€	Page 19	Page 19	Page 19	15967 / 130 €	Engine
	EMR-A: Engine electronic governor for A	N.A.	N.A.	N.A.	N.A.	N.A.	15276 / 1102€	
	EMR-RC: Engine electronic governor for RC	N.A.	N.A.	N.A.	N.A.	N.A.	15269 / 810 €	
	EMR-BUS: Engine MODBUS (needs AMF25)	N.A.	N.A.	N.A.	N.A.	N.A.	15349 / 325 €	
	AIRCALD: Air pre-heating for RC models	N.A.	N.A.	13095 / 80 €	Page 19	13095 / 80 €	13098 / 155 €	
	AIRCALD: Air pre-heating for A models	N.A.	N.A.	11777 / 165 €	Page 19	11777 / 165 €	13041 / 243 €	
	OILCALD: Oil pre-heating	3139 / 261€	15993 / 228€	N.A.	N.A.	N.A.	N.A.	
	LIQCALD: Liquid pre-heating	N.A.	N.A.	Page 19	Page 19	Page 19	N.A.	
Inst	RESID: Residential muffler	N.A.	N.A.	PAG 19	N.A.	PAG 19	3465 / 198€	Inst
	2,5FLEX50: 2,5m flexible tube for silencer	...934-032/55€	...934-032/55€	...934-032/55€	...934-032/55€	...934-032/55€	...934-032/55€	
	5FLEX50: 5m flexible tube for silencer	...934-033/93€	...934-033/93€	...934-033/93€	...934-033/93€	...934-033/93€	...934-033/93€	
Trailer	C.OBRA: Not approved trailer	1 Axle / Ball 3487 / 850€	1 Axle / Ball 3487 / 850€	Page 19	Page 19	Page 19	3138 / 947€	Trailer
	C.ART: Articulated rod	Consult us	Consult us	Page 19	Page 19	Page 19	Consult us	
	C.ARG: Ring type coupling	15335 / 40€	15335 / 40€	PAG 19	Page 19	Page 19	15335 / 40€	
	DECCOMB: Fuel decanter	N.A.	N.A.	SERIE	N.A.	SERIE	15970 / 361€	
Fuel	190L: Extra large 190L fuel tank	N.A.	N.A.	Page 19	N.A.	Page 19	18083 / 391€	Fuel
	B-TR-MN: Semi-Automatic fuel electropump	Consult us	Consult us	Page 19	Page 19	Page 19	15432 / 500€	
	B-TR-AU: Automatic fuel electropump	Consult us	Consult us	Page 19	Page 19	Page 19	15433 / 542€	



OPEN SKID GENERATORS = THREE PHASE 1500R.P.M.

50
HERTZ
1500
RPM

G5	GENERATOR TARIF 50HZ	
C	CONTINUOUS 1500rpm 24h/día --- 2000h/año	A
D/R/L	ENGINE D Deutz R Lombardini L Lister-Petter	A/W
RC	Manual-Remote panel	A
		Automatic AMF panel

KVA	Technical data	CARA T20	CALW T20	CADW T25	CADA T25	CADA T35	CALW T35	KVA
TECHNICAL DATA	Compliance emission 2002/88	YES	YES	YES	YES	YES	NO	TECHNICAL DATA
	Stand-by power/Continuous power [kVA]	20 / 18	19,5 / 17,5	25 / 22	25 / 22	35 / 31,5	35 / 31,5	
	Voltage [V] / Intensity [A] / Cos φ	400 / 28 / 0,8	400 / 28 / 0,8	400 / 36 / 0,8	400 / 36 / 0,8	400 / 50 / 0,8	400 / 50 / 0,8	
	Dimensions length x width x height [mm]	1450/750/1050	1450/750/1050	1450/750/1010	1450/750/1010	1630/850/1150	1630/850/1150	
	Dim packaging length x width x height [mm]	1500/800/1230	1500/800/1230	1500/800/1230	1500/800/1230	1700/940/1210	1700/940/1210	
	Acoustic power LWA [dBA]	100	100	98	100	103	N.D.	
	Acoustic pressure LPA [dBA] 16m/10m/7m/4m	68/72/75/80	68/72/75/80	66/70/73/78	68/72/75/80	71/75/78/83	N.D.	
	Fuel tank [l] / Autonomy 75% (PRP) [h]	30 / 9	30 / 10	30 / 8	30 / 8	60 / 11	60 / 10	
Units per container 20' / 40'	10 / 21	10 / 21	10 / 21	10 / 21	6 / 14	6 / 14		
ENGINE	Engine code	1428-0002	1435	18477	197	199	14961	ENGINE
	Model	11LD626	LPW4	D2009L04	F3L2011	F4L2011	DWS4-03	
	Manufacturer	LOMBARDINI	LISTER	DEUTZ	DEUTZ	DEUTZ	LISTER	
	Coupling	SAE 4 7/8	SAE5 7/8	SAE5 7/8	SAE3 1 1/2	SAE3 1 1/2	SAE3 1 1/2	
	Cooling system / N° cylindres /Aspiration	Air/4/Natural	Water/4/Natural	Water/4/Natural	Air/3/Natural	Air/4/Natural	Water/4/Natural	
RC	Manual-Remote panel	G5 CARA	G5 CALW	G5 CADW	G5 CADA	G5 CADA	G5 CALW	RC
		T20 RC	T20 RC	T25 RC	T25 RC	T35 RC	T35 RC	
	Generator code	3729	2091	N.A.	GED0514	GED0520	14962	
	Pricing	Retail price	5.897 €	6.261 €	N.A.	7.113 €	7.732 €	
	Net weight / With packaging [kg]	422 / 431	495 / 503		525 / 534	624 / 644	625 / 645	
ALT	Alternator code	2996	1642	Available	1641	2565	2565	ALT.
	Model	T132 MA	T132 MA		T132 LA	T132 LB	T132 LB	
	Manufacturer	SACCARDO	SACCARDO	in	SACCARDO	SACCARDO	SACCARDO	
	Regulation	COMPOUND	COMPOUND		COMPOUND	COMPOUND	COMPOUND	
	Protection index	IP23	IP23	open	IP23	IP23	IP23	
RC	Control panel type	Manual-Remote	Manual-Remote	to soundproof	Manual-Remote	Manual-Remote	Manual-Remote	RC
	Controller CPU	GPMP72+V	GPMP72+V		GPMP72 + V	GPMP72 + V	GPMP72 + V	
	Engine panel / Engine wiring harness	14988/3585	14988/129		14988/226	14988/226	14988/129	
	Power control panel / Power wiring harness	1723 / 1711	1723/1711		1723/1711	1665/1658	1665/1658	
A	Automatic AMF panel	G5 CARA	G5 CALW	G5 CADW	G5 CADA	G5 CADA	G5 CALW T35	A
		T20 A	T20 A	T25 A	T25 A	T35 A	A	
	Generator code	See Page 19	2114	GED0547	N.A.	GED0563	15015	
	Pricing	Retail price		6.790 €	7.650 €	N.A.	8.389 €	
	Net weight / With packaging [kg]		495 / 504	520 / 528		624 / 644	625 / 645	
ALT	Alternator code		18803	18808		1151	1151	ALT
	Model		LSA 40 S4	LSA 40 L7		LSA 42.2 L9	LSA 42.2 L9	
	Manufacturer		LEROY SOMER	LEROY SOMER		LEROY SOMER	LEROY SOMER	
	Regulation		AVR	AVR		AVR	AVR	
	Protection index		IP23	IP23		IP23	IP23	
AMF	Control panel type		Automatic AMF	Automatic AMF		Automatic AMF	Automatic AMF	AMF
	Controller CPU		GECO + V	GECO + V		GECO + V	GECO + V	
	Engine panel / Engine wiring harness		16745/129	16745/18526		16745/226	16745/129	
	Power control panel / Power wiring harness		1723/1711	1723/1711		1680/1658	1680/1658	
KITS	Kit mant 1000 h MOTOR	3498 / 128€	2278 / 116€		DEU-1080/ 58€	DEU-1080/ 58€	657-76130 / 280€	KITS
	Kit mant/emerg 1000 h MOTOR	3499 / 280€	2279 / 143€		DEU-1093/ 77€	DEU-1093/ 77€	15527 / 358€	
	Kit mant/emerg 1000 h ALT (T132)	1893 / 118€	1893 / 118€		1893 / 118€	1893 / 118€	1893 / 118€	
	Kit mant/emerg 1000 h ALT (TR132)		-		-	-	-	

Options	Opcionales disponibles ABREV (Code / PVP)							Options
ALT	AVR: NSM AVR alternator	Page 19	2492 / 395€	N.A.	1000-5202/ 171€	1000-5204/ 539 €	1000-5204/ 539€	ALT
	LSA: Leroy Somer alternator	Page 19	SERIE	SERIE	15544 / 171€	SERIE	SERIE	
	LSA-TR: Leroy Somer tropicalized	Page 19	XXXXX / 265€	XXXXX / 265€	15307 / 271€	14175 / 271€	14175 / 271€	
	LSA-PMG: Leroy Somer PMG system	Consult us	Consult us	Consult us	Consult us	Consult us	Consult us	
ATS	LSACALD: Leroy Somer with preheating	Page 19	XXXXX / 215€	XXXXX / 215€	12839 / 162€	14251 / 162€	14251 / 162€	ATS
	1ATS: Integrated ATS for RC models	N.A.	N.A.	N.A.	N.A.	N.A.	N.A.	
	2ATS: Separated ATS for RC models	1976 / 170€	1976 / 170€	1976 / 170€	1976 / 170€	1989 / 294€	1989 / 294€	
	2ATS: Separated ATS for A models	1977 / 212€	1977 / 212€	1977 / 212€	1977 / 212€	1999 / 479€	1999 / 479€	
Panel	TEMP: Automatic start/stop clock for RC	3017 / 131€	3017 / 131€	3017 / 131€	3017 / 131€	3017 / 131€	3017 / 131€	Panel
	220V: Output 220V voltage for RC models	Page 19	Page 19	Page 19	Page 19	15448 / 56€	15450 / 94€	
	220V: Output 220V voltage for A models	Page 19	Page 19	Page 19	Page 19	15449 / 51€	15451 / 47€	
	GPM2: GPM2 controller (A+V/A+F/V+F)	N.A.	N.A.	N.A.	N.A.	N.A.	N.A.	
	GPM3: GPM3 digital controller for RC models	N.A.	N.A.	N.A.	14231 / 230€	14231 / 230€	14231 / 230€	
	GECO-MD: GECOMD digital for A models	Page 19	Page 19	14240 / 292€	N.A.	14240 / 292€	14240 / 292€	
	AMF25: AMF25 digital for A with EMR	Page 19	Page 19	14184 / 453€	N.A.	14184 / 453€	14184 / 453€	
	PROTDIF: Differential protection A models	15439 / 80€	15439 / 80€	15439 / 80€	15440 / 80€	15441 / 89€	15441 / 89€	
	BASES: Shokets for RC models	N.A.	N.A.	N.A.	N.A.	N.A.	N.A.	
	DESCBAT: Battery disconnecter	Page 19	Page 19	Page 19	15345 / 88€	15345 / 88€	15345 / 88€	
	VDO: Press & Temp transmitt. (GPM3/AMF25)	Page 19	Page 19	Page 19	15965 / 93€	15967 / 130€	Consult us	
	EMR-A: Engine electronic governor for A	N.A.	N.A.	N.A.	15277 / 1102€	15288 / 1102€	N.A.	
EMR-RC: Engine electronic governor for RC	N.A.	N.A.	N.A.	15271 / 810€	15022 / 810€	N.A.		
EMR-BUS: Engine MODBUS (needs AMF25)	N.A.	N.A.	N.A.	15349 / 325€	15349 / 325€	15349 / 325€		
Engine	AIRCALD: Air pre-heating for RC models	Page 19	13095 / 80€	13095 / 80€	13098 / 155€	13098 / 155€	13098 / 155€	Engine
	AIRCALD: Air pre-heating for A models	Page 19	11777 / 165€	11777 / 165€	13041 / 243€	13041 / 243€	13041 / 243€	
	OILCALD: Oil pre-heating	N.A.	N.A.	N.A.	N.A.	N.A.	N.A.	
	LIQCALD: Liquid pre-heating	N.A.	Page 19	Page 19	N.A.	N.A.	13086 / 482€	
Inst	RESID: Residential muffler	Page 19	Page 19	Page 19	3465 / 198€	3465 / 198€	15284 / 198€	Inst
	2,5FLEX50: 2,5m flexible tube for silencer	...934-032/ 55€	...934-032/ 55€	...934-032/ 55€	...934-032/ 55€	...934-032/ 55€	...934-032/ 55€	
	5FLEX50: 5m flexible tube for silencer	...934-033/ 93€	...934-033/ 93€	...934-033/ 93€	...934-033/ 93€	...934-033/ 93€	...934-033/ 93€	
Trailer	C.OBRA: Not approved trailer	1 Axle / Ball	Page 19	Page 19	1 Axle / Ball	1 Axle / Ball	1 Axle / Ball	Trailer
	C.ART: Articulated rod	3138/ 947€	Page 19	Page 19	3138/ 947€	3488/ 1.062€	3488/ 1.062€	
	C.ARG: Ring type coupling	Consult us	Page 19	Page 19	Consult us	Consult us	Consult us	
	DECCOMB: Fuel decanter	15335 / 40€	Page 19	Page 19	15335 / 40€	15335 / 40€	15335 / 40€	
Fuel	190L: Extra large 190L fuel tank	N.A.	SERIE	SERIE	15970 / 362€	15970 / 362€	SERIE	Fuel
	B-TR-MN: Semi-Automatic fuel electropump	N.A.	Page 19	Page 19	17162 / 391€	17162 / 391€	N.A.	
	B-TR-AU: Automatic fuel electropump	15432 / 500€	Page 19	Page 19	15432 / 500€	15432 / 500€	15432 / 500€	
		15433 / 542€	Page 19	Page 19	15433 / 542€	15433 / 542€	15433 / 542€	



OPEN SKID GENERATORS = THREE-PHASE 1500rpm



G5	GENERATORS TARIF 50Hz			A	OPEN SKID	
C	CONTINUOUS 1500rpm 24h/día --- 2000h/año ENGINE			A	COOLING SYSTEM Air	
D	D	Deutz	A/W	A	Agua (Water)	
RC	Manul-Remote panel			A	Automatic AMF panel	

KVA	Technical data	CADA T47	CADA T47	CADA T66	CADO T65	CADW T100	CADW T115	KVA
TECHNICAL DATA	Compliance emission 2002/88	YES	NO	NO	YES	NO	YES	TECHNICAL DATA
	Stand-by power/Continuous power [KVA]	47 / 40	47 / 40	66 / 60	65/58	100 / 90	115 / 104	
	Voltage [V] / Intensity [A] / Cos φ	400 / 67 / 0,8	400 / 67 / 0,8	400 / 95 / 0,8	400 / 93 / 0,8	400 / 145 / 0,8	400 / 166 / 0,8	
	Dimensions length x width x height [mm]	1630/850/1160	1630/850/1160	1900/850/1200	1900/850/1200	2135/860/1550	2135/860/1550	
	Dim packaging length x width x height [mm]	1700/940/1210	1700/940/1210	1970/940/1240	1970/940/1240	2230/1070/1550	2230/1070/1550	
	Acoustic power LWA [dBA]	97	104	107	100	111	113	
	Acoustic pressure LPA [dBA] 16m/10m/7m/4m	65/69/72/77	72/77/79/82	75/79/82/87	68/72/76/80	79/83/86/91	81/85/88/93	
	Fuel tank [l] / Autonomy 75% (PRP) [h]	60 / 8	60 / 8	140 / 13	140 / 13	140 / 9	140 / 8	
	Units per container 20' / 40'	6 / 14	6 / 14	6 / 12	6 / 12	5 / 11	5 / 11	
	ENGINE	Engine code Model Manufacturer Coupling Cooling system / N° cylindres /Aspiration	201 BF4L2011/8 DEUTZ SAE3 11½ Air/4/Turbo	DEU-0007 F4L912/8 DEUTZ SAE3 11½ Air/4/Natural	DEU-0012 F6L912/8 DEUTZ SAE3 11½ Air/6/Natural	16013 BF4M2011C /8 DEUTZ SAE3 11½ OIL/4/Turbo	999 BF4M1013E/8 DEUTZ SAE2 11½ Water/4/Turbo	
ALT	Alternator code Model Manufacturer Regulation Protection index	I134 LSA43.2S15 LEROY SOMER AVR IP23	I134 LSA43.2S15 LEROY SOMER AVR IP23	642 LSA43.2M45 LEROY SOMER AVR IP23	642 LSA43.2M45 LEROY SOMER AVR IP23	392 LSA44.2VS45 LEROY SOMER AVR IP23	392 LSA44.2VS45 LEROY SOMER AVR IP23	ALT
RC	Manual-Remote panel	G5 CADA T47 RC	G5 CADA-912 T47RC	G5 CADA T66 RC	G5 CADO T65 RC	G5 CADW T100 RC	G5 CADW T115 RC	RC
Pricing	Generator code Retail price Net weight / With pacvkaging [kg]	GED0513 9.176 € 653 / 673	3281 9.475 € 715 / 735	GED0524 11.129 € 931 / 941	17221 11.150 € 800 / 815	998 14.702 € 980 / 1000	671 16.182 € 1000 / 1020	Pricing
RC	Control panel type Controller CPU Engine panel / Engine wiring harness Power control panel / Power wiring harness	Manual-Remote GPMR72 + V 14988/226 1669/1668	Manual-Remote GPMR72 + V 14988/358 1669/1668	Manual-Remote GPMR72 + V 14988/358 1682/1668	Manual-Remote GPM3 16169/646 1682/1668	Manual-Remote GPM3 16169/646 1709/1694	Manual-Remote GPM3 16169/646 1756/1755	RC
A	Automatic AMF panel	G5 CADA T47 A	G5 CADA-912 T47A	G5 CADA T66 A	G5 CADO T65 A	G5 CADW T100 A	G5 CADW T115 A	A
Pricing	Generator code Retail price Net weight / With pacvkaging [kg]	GED0504 9.308 € 657 / 677	3284 9.542 € 720 / 740	GED0541 11.183 € 931 / 941	17222 11.190 € 800 / 815	1009 14.615 € 980 / 1000	1013 16.064 € 1000/1020	Pricing
AMF	Control panel type Controller CPU Engine panel / Engine wiring harness Power control panel / Power wiring harness	Automatic AMF GECO + V 16745/226 1675/1668	Automatic AMF GECO + V 16745/358 1675/1668	Automatic AMF GECO + V 16745/358 1684/1668	Automatic AMF GECO MD 14840/646 1684/1668	Automatic AMF GECO MD 14840/646 1752/1694	Automatic AMF GECO MD 14840/646 1753/1755	AMF
KITS	Kit maint 1000 h ENGINE Kit maint/emerg 1000 h ENGINE Kit maint/emerg 1000 h ALTERNATOR	DEU-1090/116€ DEU-1109/136€ -	DEU-1086/108€ DEU-1085/151€ -	DEU-1089/133€ DEU-1100/167€ -	DEU-1090/116€ DEU-1109/136€ -	DEU-1114/161€ DEU-1115/272€ -	DEU-1114/161€ DEU-1115/272€ -	KITS

Options Available options (Code / Retail price)

Options	Available options (Code / Retail price)							Options
ALT	AVR: NSM AVR alternator	SERIE	SERIE	SERIE	SERIE	SERIE	SERIE	ALT
	LSA: Leroy Somer alternator	SERIE	SERIE	SERIE	SERIE	SERIE	SERIE	
	LSA-TR: Leroy Somer tropicalized	14176 / 271€	14176 / 271€	12419 / 271€	12419 / 271€	15309 / 280€	15309 / 280€	
	LSA-PMG: Leroy Somer PMG system	Consult us	Consult us	Consult us	Consult us	Consult us	Consult us	
ATS	LSACALD: Leroy Somer with preheating	15153 / 215€	15153 / 215€	15489 / 215€	15489 / 215€	15155 / 215€	15155 / 215€	ATS
	1ATS: Separated ATS for RC models	1989 / 294€	1989 / 294€	1989 / 294€	1989 / 294€	3262 / 477€	3262 / 477€	
	2ATS: Separated ATS for A models	1999 / 479€	1999 / 479€	1999 / 479€	1999 / 479€	3265 / 920€	3265 / 920€	
Panel	TEMP: Automatic start/stop clock for RC	3017 / 131€	3017 / 131€	3017 / 131€	3017 / 131€	3017 / 131€	3017 / 131€	Panel
	220V: Output 220V voltage for RC models	15452 / 185€	15452 / 185€	15454 / 409€	15454 / 409€	15456 / 610€	15458 / 745€	
	220V: Output 220V voltage for A models	15453 / 105€	15453 / 105€	15455 / 375€	15455 / 375€	15457 / 572€	15459 / 725€	
	GPM2: GM2 controller (A+V/A+F/V+F)	N.A.	N.A.	N.A.	N.A.	N.A.	N.A.	
	GPM3: GPM3 digital controller for RC models	14231 / 230€	14231 / 230€	14231 / 230€	SERIE	SERIE	SERIE	
	GECO-MD: GECOMD digital for A models	14240 / 292€	14240 / 292€	14240 / 292€	SERIE	SERIE	SERIE	
	AMF25: AMF25 digital for A with EMR	14184 / 453€	14184 / 453€	14184 / 453€	15023 / 161€	15023 / 161€	15023 / 161€	
	PROTDIF: Differential protection A models	15442 / 93€	15442 / 93€	15443 / 153€	15443 / 153€	15444 / 156€	15445 / 187€	
	BASES: Shokets for RC models	N.A.	N.A.	N.A.	N.A.	N.A.	N.A.	
	DESCBAT: Battery disconnecter	15345 / 88€	15345 / 88€	15345 / 88€	15345 / 88€	15345 / 88€	15345 / 88€	
Engine	VDO: Press & Temp transmitt. (GPM3/AMF25)	15967 / 130€	Consult us	Consult us	15967 / 130€	15968 / 140€	15968 / 140€	Engine
	EMR-A: Engine electronic governor for A	15289 / 1.069€	N.A.	N.A.	XXXX / 786€	15217/1107€	15218/1107€	
	EMR-RC: Engine electronic governor for RC	14886 / 786€	N.A.	N.A.	XXXX / 786€	15217/1107€	15218/1107€	
	EMR-BUS: Engine MODBUS (needs AMF25)	15349 / 325€	15349 / 325€	15349 / 325€	15349 / 325€	15349 / 325€	15349 / 325€	
	AIRCALD: Air pre-heating for RC models	SERIE	N.A.	N.A.	SERIE	N.A.	N.A.	
	AIRCALD: Air pre-heating for A models	SERIE	N.A.	N.A.	SERIE	N.A.	N.A.	
	OILCALD: Oil pre-heating	N.A.	3363 / 228€	3363 / 228€	N.A.	N.A.	N.A.	
Inst	LIQCALD: Liquid pre-heating	N.A.	N.A.	N.A.	N.A.	13081 / 411€	13081 / 411€	Inst
	RESID: Residential muffler	3465 / 198€	Consult us	Consult us	3465 / 198€	15971 / 515€	15971 / 515€	
	2,5FLEX50: 2,5m flexible tube for silencer	...934-032 / 53€	N.A.	17629 / 58€	12874 / 56€	12874 / 56€	12874 / 56€	
	5FLEX50: 5m flexible tube for silencer	...934-033 / 90€	N.A.	17630 / 95€	12875 / 98€	12875 / 98€	12875 / 98€	
Trailer	1 Axle / Ball	3488/1062€	3488/1062€	3489/1084€	3489/1084€	3489/1084€	3489/1084€	Trailer
	C.OBRA: Not approved trailer	3488/1062€	3488/1062€	3489/1084€	3489/1084€	3489/1084€	3489/1084€	
	C.ART: Articulated rod	Consult us	Consult us	Consult us	Consult us	Consult us	Consult us	
Fuel	C.ARG: Ring type coupling	15335 / 40€	15335 / 40€	15335 / 40€	15335 / 40€	15335 / 40€	15335 / 40€	Fuel
	DECCOMB: Fuel decanter	15970 / 361€	15970 / 361€	Consult us	15970 / 361€	SERIE	SERIE	
	235L: 47KVA / 250L: 100-115KVA	17162 / 391€	Consult us	Consult us	Consult us	12201/ 421€	12201/ 421€	
	550L: 66KVA / 645L: 100-115KVA	CONSULTAR	CONSULTAR	16483/ 469€	CONSULTAR	16482/469€	16482/469€	
	B-TR-MN: Semi-Automatic fuel electropump	15432 / 500€	15432 / 500€	15432 / 500€	15432 / 500€	15432 / 500€	15432 / 500€	
B-TR-AU: Automatic fuel electropump	15433 / 542€	15433 / 542€	15433 / 542€	15433 / 542€	15433 / 542€	15433 / 542€		



OPEN SKID GENERATORS = THREE-PHASE 1500rpm



G5	GENERATOR TARIF 50HZ			
C	CONTINUOUS 1500rpm 24h/day --- 2000h/year ENGINE		A	OPEN SKID GENERATORS
D	D	Deutz	W	COOLING SYSTEM W Agua (Water)
RC	Manual-Remote panel		A	Automatic AMF panel

KVA	Technical data	CADW T140	CADW T175	CADW T200	CADW T275	KVA	
TECHNICAL DATA	Compliance emission 2002/88	YES	YES	YES	YES	TECHNICAL DATA	
	Stand-by power/Continuous power [KVA]	140 / 125	175 / 157	200 / 180	275 / 250		
	Voltage [V] / Intensity [A] / Cos φ	400 / 200 / 0,8	400 / 250 / 0,8	400 / 288 / 0,8	400 / 396 / 0,8		
	Dimensions length x width x height [mm]	2135/860/1550	2600/1050/1650	2930/1100/1750	2930/1100/1750		
	Dim packaging length x width x height [mm]	2230/1070/1550	2620/1100/1700	2950/1160/1800	2950/1160/1800		
	Acoustic power LWA [dBA]	105	116	116	112		
	Acoustic pressure LPA [dBA] 16m/10m/7m/4m	73/77/80/85	84/88/91/96	84/88/91/96	80/84/87/92		
Fuel tank [l] / Autonomy 75% (PRP) [h]	140 / 6	200 / 8	310 / 10	310 / 8			
Units per container 20' / 40'	5 / 11	4 / 9	4 / 8	4 / 8			
ENGINE	Engine code	17496	2853	13834	14482	ENGINE	
	Model	BF4M1013FC/8	BF6M1013EC/8	BF6M1013FP/8	TCB2013L064		
	Manufacturer	DEUTZ	DEUTZ	DEUTZ	DEUTZ		
	Coupling	SAE2 11½	SAE2 11½	SAE2 11½	SAE2 11½		
	Cooling system / N° cylindres /Aspiration	Water/4/Turbo	Water/6/Turbo	Water/6/Turbo	Water/6/C.Rail		
ALT	Alternator code	639	2121	13724	407	ALT	
	Model	LSA 44.2 S75	LSA 44.2 L12	LSA 46.2 M3	LSA 46.2 L6		
	Manufacturer	LEROY SOMER	LEROY SOMER	LEROY SOMER	LEROY SOMER		
	Regulation	AVR	AVR	AVR	AVR		
	Protection index	IP23	IP23	IP23	IP23		
RC	Manual-Remote panel	G5 CADW T140 RC	G5 CADW T175 RC	G5 CADW T200 RC	G5 CADW T275 RC	RC	
	Generator code	17498	2170	14266	14413		
	Retail price	18.560 €	21.318 €	26.416 €	28.757 €		
Pricing	Net weight / With packaging [kg]	1500 / 1550	1900 / 1930	1990 / 2010	2190 / 2210	Pricing	
	Control panel type	Manual-Remote	Manual-Remote	Manual-Remote	Manual-Remote		
	Controller CPU	GPM3	GPM3	GPM3	GPM3		
RC	Engine panel / Engine wiring harness	14001/18472	16169/2973	14001/3064	14001/14699	RC	
	Power control panel / Power wiring harness	2418/1755	2418/2417	14999/2417	14999/2417		
	Generator code	G5 CADW T140 A	G5 CADW T175 A	G5 CADW T200 A	G5 CADW T275 A		
A	Automatic AMF panel	G5 CADW T140 A	G5 CADW T175 A	G5 CADW T200 A	G5 CADW T275 A	A	
	Generator code	18568	3655	13833	14414		
	Retail price	18.550 €	21.194 €	26.380 €	28.722 €		
Pricing	Net weight / With packaging [kg]	1500 / 1550	1900 / 1930	1990 / 2010	2190 / 2210	Pricing	
	Control panel type	Automatic AMF	Automatic AMF	Automatic AMF	Automatic AMF		
	Controller CPU	GECO-MD	GECO-MD	GECO-MD	GECO-MD		
AMF	Engine panel / Engine wiring harness	16749/18472	14840/2973	16749/3064	16766/14699	AMF	
	Power control panel / Power wiring harness	2865/1755	2865/2417	14997/2417	2876 / 2417		
	Kit maint 1000 h ENGINE	Consult us	DEU-1117/203€	DEU-1119/217€	15495 / 658€		
KITS	Kit maint/emerg 1000 h ENGINE	Consult us	DEU-1118/315€	DEU-1120/328€	15329 / 769€	KITS	
	Kit maint/emerg 1000 h ALTERNATOR	-	-	-	-		
	Options	Available options (Code / Retail price)					Options
ALT	AVR: NSM AVR alternator	SERIE	SERIE	SERIE	SERIE	ALT	
	LSA: Leroy Somer alternator	SERIE	SERIE	SERIE	SERIE		
	LSA-TR: Leroy Somer tropicalized	15310 / 280€	15311 / 280€	15312 / 309€	15313 / 309€		
	LSA-PMG: Leroy Somer PMG system	Consult us	Consult us	Consult us	Consult us		
	LSACALD: Leroy Somer with preheating	15491 / 215€	15492 / 215€	15493 / 215€	15494 / 215€		
ATS	1ATS: Integrated ATS for RC models	3262 / 477€	3262 / 477€	2982 / 827€	15348/1000€	ATS	
	2ATS: Separated ATS for A models	3265 / 920€	3265 / 920€	12956 / 1644€	12956/1644€		
Panel	TEMP: Automatic start/stop clock for RC	3017 / 131€	3017 / 131€	3017 / 131€	3017 / 131€	Panel	
	220V: Output 220V voltage for RC models	15460 / 443€	N.A.	N.A.	N.A.		
	220V: Output 220V voltage for A models	15461 / 430€	N.A.	N.A.	N.A.		
	GPM2: GM2 controller (A+V/A+F/V+F)	N.A.	N.A.	N.A.	N.A.		
	GPM3: GPM3 digital controller for RC models	SERIE	SERIE	SERIE	SERIE		
	GECO-MD: GECOMD digital for A models	SERIE	SERIE	SERIE	SERIE		
	AMF25: AMF25 digital for A with EMR	15023 / 161€	15023 / 161€	15023 / 161€	15023 / 161€		
	PROTDIF: Differential protection A models	15446 / 194€	15446 / 194€	15447 / 208€	15447 / 208€		
	BASES: Shokets for RC models	N.A.	N.A.	N.A.	N.A.		
	DESCBAT: Battery disconnecter	15345 / 88€	15345 / 88€	15345 / 88€	15345 / 88€		
Engine	VDO: Press & Temp transmitt. (GPM3/AMF25)	Needs EMRBUS option	15968 / 140€	Needs EMRBUS option	Needs EMRBUS option	Engine	
	EMR-A: Engine electronic governor for A	SERIE	12613 / 1006€	SERIE	SERIE		
	EMR-RC: Engine electronic governor for RC	SERIE	12613 / 1006€	SERIE	SERIE		
	EMR-BUS: Engine MODBUS (needs AMF25)	15349 / 325€	15349 / 325€	15349 / 325€	15349 / 325€		
	AIRCALD: Air pre-heating for RC models	N.A.	N.A.	N.A.	N.A.		
	AIRCALD: Air pre-heating for A models	N.A.	N.A.	N.A.	N.A.		
	OILCALD: Oil pre-heating	N.A.	N.A.	N.A.	N.A.		
	LIQCALD: Liquid pre-heating	13081 / 411€	13081 / 411€	13081 / 411€	17854 / 411€		
Inst	RESID: Residential muffler	15971 / 515€	15971 / 515€	15972 / 721€	15972 / 721€	Inst	
	2,5FLEX90: 2,5m flexible tube for silencer	3352 / 86€	3352 / 86€	3352 / 86€	N.A.		
	5FLEX90: 5m flexible tube for silencer	14339 / 148€	14339 / 148€	14339 / 148€	N.A.		
	2,5FLEX120: 2,5m flexible tube for silencer	N.A.	N.A.	N.A.	15326 / 122€		
	5FLEX120: 5m flexible tube for silencer	N.A.	N.A.	N.A.	15327 / 226€		
Trailer	C.OBRA: Not aproved trailer	Consult us	Consult us	Consult us	Consult us	Trailer	
	C.ART: Articulated rod	Consult us	Consult us	Consult us	Consult us		
	C.ARG: Ring type coupling	SERIE	SERIE	SERIE	SERIE		
Fuel	DECCOMB: Fuel decanter	SERIE	SERIE	SERIE	SERIE	Fuel	
	XXXL: Extra large fuel tanks	Consult us	Consult us	Consult us	Consult us		
	B-TR-MN: Semi-Automatic fuel electropump	15432 / 500€	15432 / 500€	15432 / 500€	15432 / 500€		
B-TR-AU: Automatic fuel electropump	15433 / 542€	15433 / 542€	15433 / 542€	15433 / 542€			

Open skid generators - 1500rpm - 24h/day - 2000h/year

Open skid to soundproof - 1500rpm - 24h/day - 2000h/year



1 ~

3 ~

1500
RPM

50
HERTZ

Open skid to soundproof - 1500rpm - 24h/day - 2000h/year

1 ~

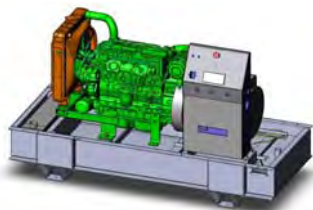

OPEN SKID TO SOUNDPROOF = SINGLE-PHASE 1500R.P.M.

G5	GENERATORS TARIF 50Hz					
C	CONTINUOUS 1500rpm 24h/día --- 2000h/año			A Open with possibility of soundproofing		
L/D	ENGINE			COOLING SYSTEM		
	L	Lister-Petter		W/O	W	Agua (Water)
	D	Deutz			O	Aceite (Oil)
RC	Manual - Remote panel			A Automatic AMF panel		

50 HERTZ

1500 RPM

KVA	Technical data	CALW M9	CALW M13	CALW M16	CADW M21	CADO M31	CADO M42	KVA
TECHNICAL DATA	Compliance emissions 2002/88	Exempt	Exempt	Exempt	YES	YES	YES	TECHNICAL DATA
	Compliance noise 2000/14/CE	YES	YES	YES	YES	NO	NO	
	Stand-by power/Continuous power [kVA]	9 / 8	13 / 11	16 / 14	20,6 / 18	30,5 / 28	42 / 38	
	Voltage [V] / Intensity [A] / Cos φ	230/39/0,9	230/56/0,9	230/69/0,9	230/91/0,9	230/132/0,9	230/180/0,9	
	Dimensions length x width x height [mm]	1800/740/1170	1800/740/1170	1800/740/1170	1800/740/1170	2250/950/1250	2250/950/1250	
	Dim packaging length x width x height [mm]	1800/750/1170	1800/750/1170	1800/750/1170	1800/750/1170	2300/1000/1250	2300/1000/1250	
	Acoustic power LWA [dBA]	96	96	97	96	99	99	
	Acoustic pressure LPA [dBA] 16m/10m/7m/4m	64/68/71/76	64/68/71/76	65/69/72/77	64/68/71/76	67/71/74/79	67/71/74/79	
	Fuel tank [l] / Autonomy 75% (PRP) [h]	50 / 33	50 / 23	50 / 17	50 / 12,5	100 / 17	100 / 13,5	
	Units per container 20' / 40'	9 / 19	9 / 19	9 / 19	9 / 19	6 / 12	6 / 12	

ALT	Engine code	18798	18803	18802	14229	1134	642	ALT
	Model	LSA 40 VS2	LSA 40 S4	LSA 40 L7	LSA 42.2 L9	LSA 43.2 S15	LSA 43.2 M45	
	Manufacturer	LEROY SOMER	LEROY SOMER	LEROY SOMER	LEROY SOMER	LEROY SOMER	LEROY SOMER	
	Coupling	AVR	AVR	AVR	AVR	AVR	AVR	
	Cooling system / N° cylindres /Aspiration	IP23	IP23	IP23	IP23	IP23	IP23	

ENGINE	Alternator code	12531	12536	12535	18476	DEU-0020	DEU-0021	ENGINE
	Model	LPW2	LPW3	LPW4	D2009L04	F4M2011	BF4M2011	
	Manufacturer	LISTER	LISTER	LISTER	DEUTZ	DEUTZ	DEUTZ	
	Regulation	SAE5 7½	SAE5 7½	SAE5 7½	SAE5 7½	SAE3 11½	SAE3 11½	
	Protection index	Water/2/Nat	Water/3/Nat	Water/4/Nat	Water/4/Turbo	Oil/4/Natural	Oil/4/Turbo	

RC	Manual - Remote panel	G5 CALW M9C1 RC	G5 CALW M13C1 RC	G5 CALW M16C1 RC	G5 CADW M21C1 RC	G5 CADO M31C2 RC	G5 CADO M42C2 RC	RC
Pricing	Generator code	18945	18947	18949	18951	18953	18955	Pricing
	Retail price	5.333 €	6.080 €	6.929 €	8.323 €	9.800 €	10.995 €	
	Net weight / With Packaging [kg]	498 / 507	7570	619 / 628	715 / 730	1000 / 1015	975 / 985	

RC	Control panel type	Manual-Remote	Manual-Remote	Manual-Remote	Manual-Remote	Manual-Remote	Manual-Remote	RC
Pricing	Controller CPU	GPM3	GPM3	GPM3	GPM3	GPM3	GPM3	Pricing
	Engine panel / Engine wiring harness	16169/129	16169/129	16169/129	16169/18526	16169/226	18454/226	
	Power control panel / Power wiring harness	2652/908	2545/544	2668/544	2 / 544	2641/440	11878/440	

A	Automatic mains failure AMF panel	G5 CALW M9C1 A	G5 CALW M13C1 A	G5 CALW M16C1 A	G5 CADW M21C1 A	G5 CADO M31C2 A	G5 CADO M42C2 A	A
Pricing	Generator code	18946	18948	18950	18952	18954	18956	Pricing
	Retail price	5.493 €	6.156 €	6.987 €	8.364 €	9.855 €	11.095 €	
	Net weight / With packaging [kg]	498 / 507	564 / 573	619 / 628	720 / 735	925 / 935	975 / 985	

AMF	Control panel type	Automatic-AMF	Automatic-AMF	Automatic-AMF	Automatic-AMF	Automatic-AMF	Automatic-AMF	AMF
Pricing	Controller CPU	GECO MD	GECO MD	GECO MD	GECO MD	GECO MD	GECO MD	Pricing
	Engine panel / Engine wiring harness	14840 / 129	14840/129	14840/129	14840 / 18526	14840/226	14840/226	
	Power control panel / Power wiring harness	2656/908	2581/544	2676/544	797 / 544	2642/440	11879/440	

KITS	Kit maint 1000 h ENGINE	2276 / 108€	2278 / 116€	2278 / 116€	CONSULTAR	DEU-1090 / 116€	DEU-1090 / 116€	KITS
	Kit maint/emerg 1000 h ENGINE	2277 / 143€	2279 / 143€	2279 / 143€	CONSULTAR	DEU-1098 / 133€	DEU-1101 / 133€	

Options Available options (Code / Retail price)

ALT	AVR: NSM AVR alternator	SERIE	SERIE	SERIE	SERIE	SERIE	SERIE	ALT
	LSA: Leroy Somer alternator	SERIE	SERIE	SERIE	SERIE	SERIE	SERIE	
	LSA-TR: Leroy Somer tropicalized	XXXX / 271€	XXXX / 271€	XXXXX / 271€	XXXXX / 271€	14176 / 271€	12419 / 271€	
	LSA-PMG: Leroy Somer PMG system	Consult us	Consult us	Consult us	Consult us	Consult us	Consult us	
	LSACALD: Leroy Somer with preheating	XXXX / 203€	XXXX / 162€	XXXXX / 162€	XXXXX / 162€	15153 / 215€	15489 / 215€	
ATS	1ATS: Integrated ATS for RC models	N.A.	N.A.	N.A.	N.A.	N.A.	N.A.	ATS
	1ATS: Separated ATS for RC models	15925 / 170€	15926 / 294€	15926 / 294€	15926 / 294€	15926 / 294€	3262 / 477€	
	2ATS: Separated ATS for A models	15928 / 212€	15929 / 479€	15929 / 479€	15929 / 479€	15929 / 479€	3265 / 920€	
Panel	TEMP: Automatic start/stop clock for RC	3017 / 131€	3017 / 131€	3017 / 131€	3017 / 131€	3017 / 131€	3017 / 131€	Panel
	GPM2: GM2 controller (A+V/A+P/V+F)	N.A.	N.A.	N.A.	N.A.	N.A.	N.A.	
	GPM3: GPM3 digital controller for RC models	SERIE	SERIE	SERIE	SERIE	SERIE	SERIE	
	GECO-MD: GECOMD digital for A models	SERIE	SERIE	SERIE	SERIE	SERIE	SERIE	
	AMF25: AMF25 digital for A with EMR	15023 / 161€	15023 / 161€	15023 / 161€	15023 / 161€	15343 / 161€	15343 / 161€	
	PROTDIF: Differential protection A models	15406 / 18€	15407 / 118€	15408 / 126€	15464 / 154€	15465 / 147€	15466 / 206€	
	BASES: Shokets for RC models	15147 / 118€	15147 / 118€	15147 / 118€	N.A.	N.A.	N.A.	
	DESCBAT: Battery disconnecter	15345 / 88€	15345 / 88€	15345 / 88€	15345 / 88€	15345 / 88€	15345 / 88€	
	VDO: Press & Temp transmitt. (GPM3/AMF25)	15965 / 88€	15965 / 88€	15965 / 88€	18803 / 250€	15967 / 130€	15967 / 130€	
	EMR-A: Engine electronic governor for A	N.A.	N.A.	N.A.	N.A.	15209 / 810€	14892 / 810€	
EMR-RC: Engine electronic governor for RC	N.A.	N.A.	N.A.	N.A.	15209 / 810€	14892 / 810€		
EMR-BUS: Engine MODBUS (needs AMF25)	N.A.	N.A.	N.A.	N.A.	15349 / 315€	15349 / 315€		
Engine	AIRCALD: Air pre-heating for RC models	19156 / 70€	19156 / 70€	19156 / 70€	N.A.	19157 / 145€	SERIE	Engine
	AIRCALD: Air pre-heating for A models	19158 / 75€	19158 / 75€	19158 / 75€	N.A.	19159 / 150€	SERIE	
	OILCALD: Oil pre-heating	N.A.	N.A.	N.A.	N.A.	N.A.	N.A.	
	LIQCALD: Liquid pre-heating	13086/482€	13086/482€	13086/482€	13081/411€	N.A.	N.A.	
	RESID: Residential muffler	SERIE	SERIE	SERIE	SERIE	SERIE	SERIE	
Inst	2,5FLEX50 (LISTER) / Ø60 (DEUTZ)	...934-032/55€	...934-032/55€	...934-032/55€	...934-032/55€	12874 / 57€	12874 / 57€	Inst
	5FLEX50 (LISTER) / Ø60 (DEUTZ)	...934-033/93€	...934-033/93€	...934-033/93€	...934-033/93€	12875 / 98€	12875 / 98€	
	C1/C2 (Soundproofing option price)	1.800 €	1.800 €	1.800 €	1.800 €	2.200 €	2.200 €	

Trailer	C.OBRA: Not aproved trailer	1Axle / Ball	1Axle / Ball	1Axle / Ball	1Axle / Ball	1Axle / Ball	1Axle / Ball	Trailer
		Consult us	Consult us	Consult us	Consult us	Consult us	Consult us	
	C.HOMOL: Aproved trailer (In Spain)	N.A.	N.A.	N.A.	N.A.	N.A.	N.A.	
Fuel	C.ART: Articulated rod	Consult us	Consult us	Consult us	Consult us	Consult us	Consult us	Fuel
	C.ARG: O-hitch ring or ballmount coupling	SERIE	SERIE	SERIE	SERIE	SERIE	SERIE	
	RETEN: 110% liquid retention tray	SERIE	SERIE	SERIE	SERIE	SERIE	SERIE	
	B.SOLD: Internally welded retention tray	SERIE	SERIE	SERIE	SERIE	SERIE	SERIE	
	DECCOMB: Fuel decanter	SERIE	SERIE	SERIE	SERIE	SERIE	SERIE	
Fuel	190L (C1) 250L (C2): Extra large fuel tanks	13493/273€	13493/273€	13493/273€	13493/273€	18158 / 350€	18158 / 350€	Fuel
	B-TR-MN: Semi-Automatic fuel electropump	15432 / 500€	15432 / 500€	15432 / 500€	15432 / 500€	3046 / 500€	3046 / 500€	
	B-TR-AU: Automatic fuel electropump	15433 / 542€	15433 / 542€	15433 / 542€	15433 / 542€	12488 / 542€	12488 / 542€	

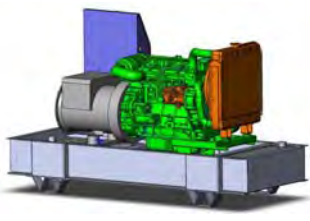

OPEN SKID TO SOUNDPROOF = THREE PHASE 1500R.P.M.

G5	GENERATORS TARIF 50Hz					
C	CONTINUOUS 1500rpm 24h/day --- 2000h/year			I OPEN WITH SOUNDPROOFING POSSIBILITY		
L/D	ENGINE			COOLING SYSTEM		
	L	Lister-Petter		W/O	W	Agua (Water)
	D	Deutz			O	Acete (Oil)
RC	Manual - Remote panel			A Automatic AMF panel		

50 HERTZ

1500 RPM

KVA	Technical data	CADO M55	CALW T10	CALW T15	CALW T20	CADW T25	CADO T35	KVA
TECHNICAL DATA	Compliance emissions 2002/88	YES	Exempt	Exempt	Exempt	YES	YES	TECHNICAL DATA
	Compliance noise 2000/14/CE	NO	YES	YES	YES	YES	NO	
	Stand-by power/Continuous power [kVA]	55 / 50	10 / 9	14 / 12,5	19,5 / 17,5	25 / 23	35 / 31,5	
	Voltage [V] / Intensity [A] / Cos φ	230/239/0,9	400 / 14 / 0,8	400 / 21 / 0,8	400 / 28 / 0,8	400 / 36 / 0,8	400 / 50 / 0,8	
	Dimensions length x width x height [mm]	2250/950/1250	1800/740/1170	1800/740/1170	1800/740/1170	1800/740/1170	2250/950/1250	
	Dim packaging length x width x height [mm]	2300/1000/1250	1800/750/1170	1800/750/1170	1800/750/1170	1800/750/1170	2300/1000/1250	
	Acoustic power LWA [dBA]	99	96	96	97	96	99	
	Acoustic pressure LPA [dBA] 16m/10m/7m/4m	67/71/74/79	64/68/71/76	64/68/71/76	65/69/72/77	64/68/71/76	67/71/74/79	
	Fuel tank [l] / Autonomy 75% (PRP) [h]	100 / 12,5	50 / 33	50 / 23	50 / 17	50 / 12,5	100 / 17	
	Units per container 20' / 40'	6 / 12	9 / 19	9 / 19	9 / 19	9 / 19	5 / 10	

ALT	Engine code	207	18805	18798	18803	18802	1151	ALT
	Model	LSA 43.2 L8	LSA 40 VS1	LSA 40 VS2	LSA 40 S4	LSA 40 L7	LSA 42.2 L9	
	Manufacturer	LEROY SOMER	LEROY SOMER	LEROY SOMER	LEROY SOMER	LEROY SOMER	LEROY SOMER	
	Coupling	AVR	AVR	AVR	AVR	AVR	AVR	
	Cooling system / N° cylindres /Aspiration	IP23	IP23	IP23	IP23	IP23	IP23	

ENGINE	Alternator code	18150	12531	12536	12535	18476	DEU-0020	ENGINE
	Model	BF4M2011C	LPW2	LPW3	LPW4	D2009L04	F4M2011	
	Manufacturer	DEUTZ	LISTER	LISTER	LISTER	DEUTZ	DEUTZ	
	Regulation	SAE3 11½	SAE5 7½	SAE5 7½	SAE5 7½	SAE5 7½	SAE3 11½	
	Protection index	Oil/4/Turbo	Water/2/Natural	Water/3/Natural	Water/4/Natural	Water/4/Turbo	Oil/4/Nat	

RC	Manual - Remote panel	G5 CADO M55C2 RC	G5 CALW T10C1 RC	G5 CALW T15C1 RC	G5 CALW T20C1 RC	G5 CADW T25C1 RC	G5 CADO T35C2 RC	RC
	Generator code	19008	18957	18959	18961	18963	18965	
Pricing	Retail price	13.485 €	5.219 €	5.850 €	6.740 €	7.895 €	9.495 €	Pricing
	Net weight / With Packaging [kg]	1020 / 1040	500 / 510	550 / 560	650 / 665	690 / 700	1000 / 1015	
	Control panel type	Manual-Remote	Manual Remote	Manual Remote	Manual Remote	Manual Remote	Manual Remote	

RC	Controller CPU	6PM3	6PM3	6PM3	6PM3	6PM3	6PM3	RC
	Engine panel / Engine wiring harness	18454/226	16169/129	16169/129	16169/129	16169 / 18526	16778/226	
	Power control panel / Power wiring harness	11880/440	16214/1711	3245/1711	1723/1711	1723 / 1711	1665/1668	
	Control panel type	Automatic AMF	Automatic AMF	Automatic AMF	Automatic AMF	Automatic AMF	Automatic AMF	

A	Automatic mains failure AMF panel	G5 CADO M55C2 A	G5 CALW T10C1 A	G5 CALW T15C1 A	G5 CALW T20C1 A	G5 CADW T25C1 A	G5 CADO T35C2 A	A
	Generator code	19009	18958	18960	18962	18964	18966	
Pricing	Retail price	13.350 €	5.399 €	5.990 €	6.890 €	8.095 €	9.581 €	Pricing
	Net weight / With packaging [kg]	1020 / 1040	500 / 510	550 / 560	650 / 665	690 / 700	1000 / 1015	
	Control panel type	Automatic AMF	Automatic AMF	Automatic AMF	Automatic AMF	Automatic AMF	Automatic AMF	

AMF	Controller CPU	GECO MD	GECO MD	GECO MD	GECO MD	GECO MD	GECO MD	AMF
	Engine panel / Engine wiring harness	14840/226	14840/129	14840/129	14840/129	14840 / 18526	14840/226	
	Power control panel / Power wiring harness	11881/440	16214/1711	3245/1711	1723/1711	1723 / 1711	1680/1668	
	Kit maint 1000 h ENGINE	Consult us	2276 / 108€	2278 / 116€	2278 / 116€	Consult us	DEU-1090/ 116€	

KITS	Kit maint/emerg 1000 h ENGINE	Consult us	2277 / 143€	2279 / 143€	2279 / 143€	Consult us	DEU-1098/ 133€	KITS
	Options	Available options (Code / Retail price)						

ALT	LSA: Leroy Somer alternator	SERIE	SERIE	SERIE	SERIE	SERIE	SERIE	ALT
	LSA-TR: Leroy Somer tropicalized	12419 / 271€	XXXXX / 271€	XXXXX / 271€	XXXXX / 271€	XXXXX / 271€	14175 / 271€	
	LSA-PMG: Leroy Somer PMG system	Consult us	Consult us	Consult us	Consult us	Consult us	Consult us	
	LSACALD: Leroy Somer with preheating	15489 / 215€	XXXXX / 203€	XXXXX / 203€	XXXXX / 203€	XXXXX / 162€	14251 / 162€	

ATS	1ATS: Integrated ATS for RC models	N.A.	N.A.	N.A.	N.A.	N.D.	N.D.	ATS
	1ATS: Separated ATS for RC models	3262 / 477€	1976 / 170€	1976 / 170€	1976 / 170€	1976 / 170€	1989 / 294€	
	2ATS: Separated ATS for A models	3265 / 920€	1977 / 212€	1977 / 212€	1977 / 212€	1977 / 212€	1999 / 479€	
	TEMP: Automatic start/stop clock for RC	3017 / 131€	3017 / 131€	3017 / 131€	3017 / 131€	3017 / 131€	3017 / 131€	
	220V: Output voltage 220V for RC models	N.A.	15400 / 20€	15393 / 58€	15395 / 54€	15383 / 74€	15398 / 280€	

Panel	220V: Output voltage 220V for A models	N.A.	15401 / 16€	15394 / 42€	15396 / 58€	15386 / 102€	15399 / 102€	Panel
	GPM2: GM2 controller (A+V/A+F+V+F)	N.A.	N.A.	N.A.	N.A.	N.A.	N.A.	
	GPM3: GPM3 digital controller for RC models	SERIE	SERIE	SERIE	SERIE	SERIE	SERIE	
	GECO-MD: GECOMD digital for A models	SERIE	SERIE	SERIE	SERIE	SERIE	SERIE	
	AMF25: AMF25 digital for A with EMR	15023 / 161€	15023 / 161€	15023 / 161€	15023 / 161€	15343 / 161€	15343 / 161€	
	PROTDIF: Differential protection A models	N.A.	15437 / 76€	15438 / 73€	15439 / 80€	15467 / 121€	15468 / 119€	
	BASES: Shokets for RC models	N.A.	15145 / 118€	15145 / 118€	15145 / 118€	16014 / 200€	16015 / 200€	
	DESCBAT: Battery disconnecter	15345 / 88€	15345 / 88€	15345 / 88€	15345 / 88€	15345 / 88€	15345 / 88€	
	VDO: Press & Temp transmitt. (GPM3/AMF25)	15967 / 130€	15965 / 88€	15965 / 88€	15965 / 88€	18803 / 250€	15967 / 130€	
	EMR-A: Engine electronic governor for A	15209 / 810€	N.A.	N.A.	N.A.	N.A.	15209 / 810€	

Engine	EMR-RC: Engine electronic governor for RC	15209 / 810€	N.A.	N.A.	N.A.	N.A.	15209 / 810€	Engine
	EMR-BUS: Engine MODBUS (needs AMF25)	15349 / 325€	15349 / 325€	15349 / 325€	15349 / 325€	N.A.	15349 / 325€	
	AIRCALD: Air pre-heating for RC models	SERIE	19156 / 70€	19156 / 70€	19156 / 70€	N.A.	19157 / 145€	
	AIRCALD: Air pre-heating for A models	SERIE	19158 / 75€	19158 / 75€	19158 / 75€	N.A.	19159 / 150€	
	LIQCALD: Liquid pre-heating	N.A.	13086 / 482€	13086 / 482€	13086 / 482€	13081 / 411€	N.A.	

Inst	RESID: Residential muffler	SERIE	SERIE	SERIE	SERIE	SERIE	SERIE	Inst
	2,5FLEX50 (LISTER) / Ø60 (DEUTZ)	12874 / 57€	...934-032/ 55€	...934-032/ 55€	...934-032/ 55€	...934-032/ 55€	12874 / 57€	
	5FLEX50 (LISTER) / Ø60 (DEUTZ)	12875 / 98€	...934-033/ 92€	...934-033/ 92€	...934-033/ 92€	...934-033/ 92€	12875 / 98€	
	C1/C2 (Soundproofing option price)	2.200 €	1.800 €	1.800 €	1.800 €	1.800 €	2.200 €	

Trailer	C.OBRA: Not approved trailer	1 Axle / Ball	1Axle / Ball	1Axle / Ball	1Axle / Ball	1Axle / Ball	1 Axle / Ball	Trailer
		956/ 1056€	15518 / 920€	15518 / 920€	15518 / 920€	15518 / 920€	956/ 1056€	
	C.HOMOL: Approved trailer	N.A.	N.A.	N.A.	N.A.	N.A.	N.A.	

Fuel	RETEN: 110% liquid retention tray	SERIE	SERIE	SERIE	SERIE	SERIE	SERIE	Fuel
	B.SOLD: Internally welded retention tray	SERIE	SERIE	SERIE	SERIE	SERIE	SERIE	
	DECCOMB: Fuel decanter	15970 / 361€	SERIE	SERIE	SERIE	SERIE	15970 / 361€	
	190L (C1) 250L (C2): Extra large fuel tanks	18158 / 350€	13493 / 273€	13493 / 273€	13493 / 273€	13493 / 273€	18158 / 350€	
	B-TR-MN: Semi-Automatic fuel electropump	3046 / 500€	15432 / 500€	15432 / 500€	15432 / 500€	15432 / 500€	3046 / 500€	



Foto: Con opción de carrocería

OPEN SKID TO SOUNDPROOF = THREE-PHASE 1500rpm						
G5	GENERATORS TARIF 50Hz					
C	CONTINUOUS 1500rpm 24h/día --- 2000h/año		I	OPEN SETS (With soundproofing possibility)		
L/D	ENGINE		W/O	COOLING SYSTEM		
	L	Lister-Petter		W	Agua (Water)	
	D	Deutz		O	Aceite (Oil)	
RC	Manual-Remote panel		A	Automatic AMF panel		



KVA	Technical data	CADO T47	CADO T65	CADW T100	CADW T115	CADW T140	KVA
TECHNICAL DATA	Compliance emissions 2002/88	YES	YES	NO	YES	YES	TECHNICAL DATA
	Compliance noise 2000/14/CE	YES	YES	NO	NO	NO	
	Stand-by power/Continuous power [kVA]	47 / 42	65 / 58	100 / 90	115 / 104	140 / 125	
	Voltage [V] / Intensity [A] / Cos φ	400 / 67 / 0,8	400 / 93 / 0,8	400 / 145 / 0,8	400 / 166 / 0,8	400 / 200 / 0,8	
	Dimensions length x width x height [mm]	2250/950/1250	2250/950/1250	3000/1100/1480	3000/1100/1480	3000/1100/1480	
	Dim packaging length x width x height [mm]	2300/1000/1250	2300/1000/1250	3050/1130/1480	3050/1130/1480	3050/1130/1480	
	Acoustic power LWA [dBA]	97	97	99	101	103	
	Acoustic pressure LPA [dBA] 16m/10m/7m/4m	65/69/72/77	65/69/72/77	67/71/74/79	69/73/76/81	71/75/78/83	
	Fuel tank [l] / Autonomy 75% (PRP) [h]	80 / 11	100 / 9,5	150 / 10	150 / 8	150 / 6	
	Units per container 20' / 40'	5 / 10	6 / 12	2 / 6	2 / 6	2 / 6	
ALT	Engine code	1134	642	392	392	639	ALT
	Model	LSA43.2S15	LSA43.2M45	LSA44.2VS45	LSA44.2VS45	LSA44.2S75	
	Manufacturer	LEROY SOMER	LEROY SOMER	LEROY SOMER	LEROY SOMER	LEROY SOMER	
	Coupling	AVR	AVR	AVR	AVR	AVR	
	Cooling system / N° cylindres /Aspiration	IP23	IP23	IP23	IP23	IP23	
ENGINE	Alternator code	DEU-0021	18150	999	714	2852	ENGINE
	Model	BF4M2011	BF4M2011C	BF4M1013E	BF4M1013EC	BF4M1013FC	
	Manufacturer	DEUTZ	DEUTZ	DEUTZ	DEUTZ	DEUTZ	
	Regulation	SAE3 11½	SAE3 11½	SAE2 11½	SAE2 11½	SAE2 11½	
	Protection index	Oil/4/Turbo	Oil/4/Turbo	Water/4/Turbo	Water/4/Turbo	Water/6/Turbo	
RC	Manual - Remote panel	G5 CADO T47C2 RC	G5 CADO T65C2 RC	G5 CADW T100C3 RC	G5 CADW T115C3 RC	G5 CADW T140C3 RC	RC
	Generator code	18967	18969	18971	18973	18975	
	Retail price	10.450 €	11.980 €	sept-2010	sept-2010	sept-2010	
RC	Control panel type	Manual-Remote	Manual-Remote	Manual-Remote	Manual-Remote	Manual-Remote	RC
	Controller CPU	GPM3	GPM3	GPM3	GPM3	GPM3	
	Engine panel / Engine wiring harness	14854/226	14854/226	16778/646	16777/646	16779/18472	
A	Automatic mains failure AMF panel	G5 CADO T47C2 A	G5 CADO T65C2 A	G5 CADW T100C3 A	G5 CADW T115C3 A	G5 CADW T140C3 A	A
	Generator code	18968	18970	18972	18974	18976	
	Retail price	10.590 €	11.950 €	sept-2010	sept-2010	sept-2010	
AMF	Control panel type	Automatic AMF	Automatic AMF	Automatic AMF	Automatic AMF	Automatic AMF	AMF
	Controller CPU	GECO MD	GECO MD	GECO MD	GECO MD	GECO MD	
	Engine panel / Engine wiring harness	14840/226	14840 / 226	16781/646	16782/646	16783/18472	
KITS	Kit maint 1000 h ENGINE	DEU-1090/116€	DEU-1090/116€	DEU-1114/161€	DEU-1114/ 161€	Consult us	KITS
	Kit maint/emerg 1000 h ENGINE	DEU-1101/135€	DEU-1101 / 135€	DEU-1115/272€	DEU-1115/ 272€	Consult us	
Options	Available options (Code / Retail price)						Options
ALT	LSA: Leroy Somer alternator	SERIE	SERIE	SERIE	SERIE	SERIE	ALT
	LSA-TR: Leroy Somer tropicalized	14176 / 271€	12419 / 271€	15309 / 280€	15309 / 280€	15310 / 280€	
	LSA-PMG: Leroy Somer PMG system	Consult us	Consult us	Consult us	Consult us	Consult us	
	LSACALD: Leroy Somer with preheating	15153 / 215€	15489 / 215€	15155 / 215€	15155 / 215€	15491 / 215€	
ATS	1ATS: Integrated ATS for RC models	N.A.	N.A.	N.A.	N.A.	N.A.	ATS
	1ATS: Separated ATS for RC models	1989 / 294€	1989 / 294€	3262 / 477€	3262 / 477€	3262 / 477€	
	2ATS: Separated ATS for A models	1999 / 479€	1999 / 479€	3265 / 920€	3265 / 920€	3265 / 920€	
	TEMP: Automatic start/stop clock for RC	3017 / 131€	3017 / 131€	3017 / 131€	3017 / 131€	3017 / 131€	
Panel	220V: Output voltage 220V for RC models	15391 / 279€	15454 / 409€	15480 / 608€	15482 / 826€	15484 / 533€	Panel
	220V: Output voltage 220V for A models	15392 / 102€	15455 / 375€	15481 / 571€	15483 / 848€	15485 / 547€	
	GPM2: GM2 controller (A+V/A+F/V+F)	N.A.	N.A.	N.A.	N.A.	N.A.	
	GPM3: GPM3 digital controller for RC models	SERIE	SERIE	SERIE	SERIE	SERIE	
	GECO-MD: GECOMD digital for A models	SERIE	SERIE	SERIE	SERIE	SERIE	
	AMF25: AMF25 digital for A with EMR	15343 / 161€	15023 / 161€	15343 / 161€	15343 / 161€	15343 / 161€	
	PROTDIF: Differential protection A models	15469 / 119€	15443 / 170€	15471 / 147€	15472 / 193€	15473 / 179€	
	BASES: Shokets for RC models	16016 / 300€	CONS	18052 / 412€	18052 / 412€	18052 / 412€	
	DESCBAT: Battery disconnecter	15345 / 88€	15345 / 88€	15345 / 88€	15345 / 88€	15345 / 88€	
	VDO: Press & Temp transmitt. (GPM3/AMF25)	15967 / 130€	15967 / 130€	15968 / 140€	15968 / 140€	15968 / 140€	
Engine	EMR-A: Engine electronic governor for A	14892 / 810€	XXXX / 810€	15217/1107€	15218/1107€	SERIE	Engine
	EMR-RC: Engine electronic governor for RC	14892 / 810€	XXXX / 810€	15217/1107€	15218/1107€	SERIE	
	EMR-BUS: Engine MODBUS (needs AMF25)	15349 / 325€	15349 / 325€	15349 / 325€	15349 / 325€	15349 / 325€	
	AIRCALD: Air pre-heating for RC models	SERIE	SERIE	N.A.	N.A.	N.A.	
	AIRCALD: Air pre-heating for A models	SERIE	SERIE	N.A.	N.A.	N.A.	
	LIQCALD: Liquid pre-heating	N.A.	N.A.	13081 / 411€	13081 / 411€	13081 / 411€	
Inst	RESID: Residential muffler	SERIE	SERIE	SERIE	SERIE	SERIE	Inst
	2,5FLEX60 (T35-T47) / Ø100 (T70-T150)	12874 / 57€	12874 / 57€	15324 / 85€	15324 / 85€	15324 / 85€	
	5FLEX60 (T35-T47) / Ø100 (T70-T150)	12875 / 98€	12875 / 98€	15325 / 162€	15325 / 162€	15325 / 162€	
Trailer	C2/C3 (Soundproofing option price)	2.200 €	2.200 €	sep-10	sep-10	sep-10	Trailer
	C.OBRA: Not aproved trailer	1 Axle / Ball 956/1056€	1 Axle / Ball CONSULTAR	2 Axles / ARG 1339/1211€	2 Axles / ARG 1339/1211€	2 Axles / ARG 1339/1211€	
	C.HOMOL: Aproved trailer (In Spain)	N.A.	N.A.	N.A.	N.A.	N.A.	
	C.ART: Articulated rod	Consult us	Consult us	Consult us	Consult us	Consult us	
Fuel	C.ARG: O-hitch ring or ballmount coupling	Consult us	Consult us	Consult us	Consult us	Consult us	Fuel
	B.RETEN: 110% liquids retention tray	SERIE	SERIE	SERIE	SERIE	SERIE	
	B.SOLD: Internally welded retention tray	SERIE	SERIE	SERIE	SERIE	SERIE	
	DECCOMB: Fuel decanter	15970 / 361€	15970 / 361€	SERIE	SERIE	SERIE	
	250L (C2) : Extra large fuel tanks	18158 / 350€	18158 / 350€	Consult us	Consult us	Consult us	
B-TR-MN: Semi-Automatic fuel electropump	3046 / 500€	3046 / 500€	3046 / 500€	3046 / 500€	3046 / 500€		
B-TR-AU: Automatic fuel electropump	12488 / 542€	12488 / 542€	12488 / 542€	12488 / 542€	12488 / 542€		

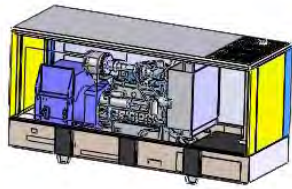
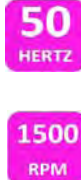
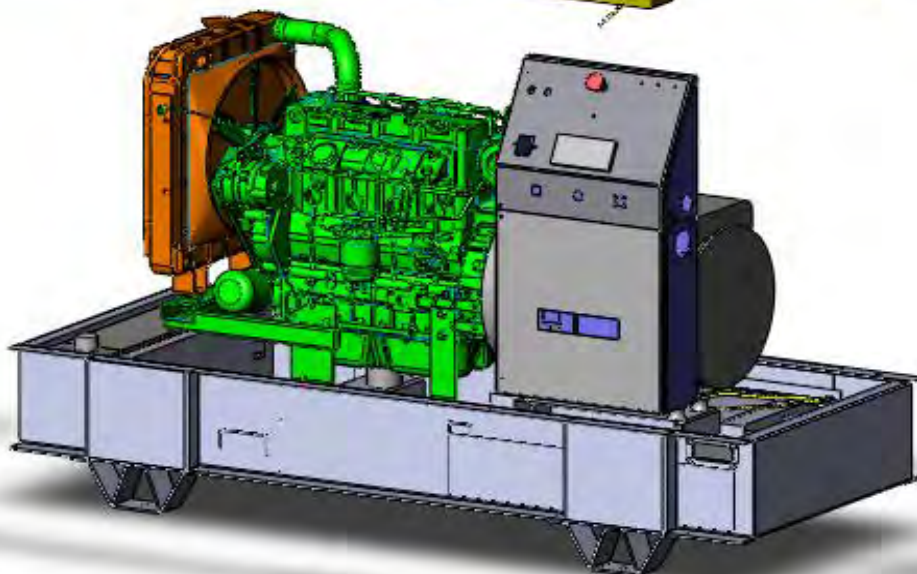
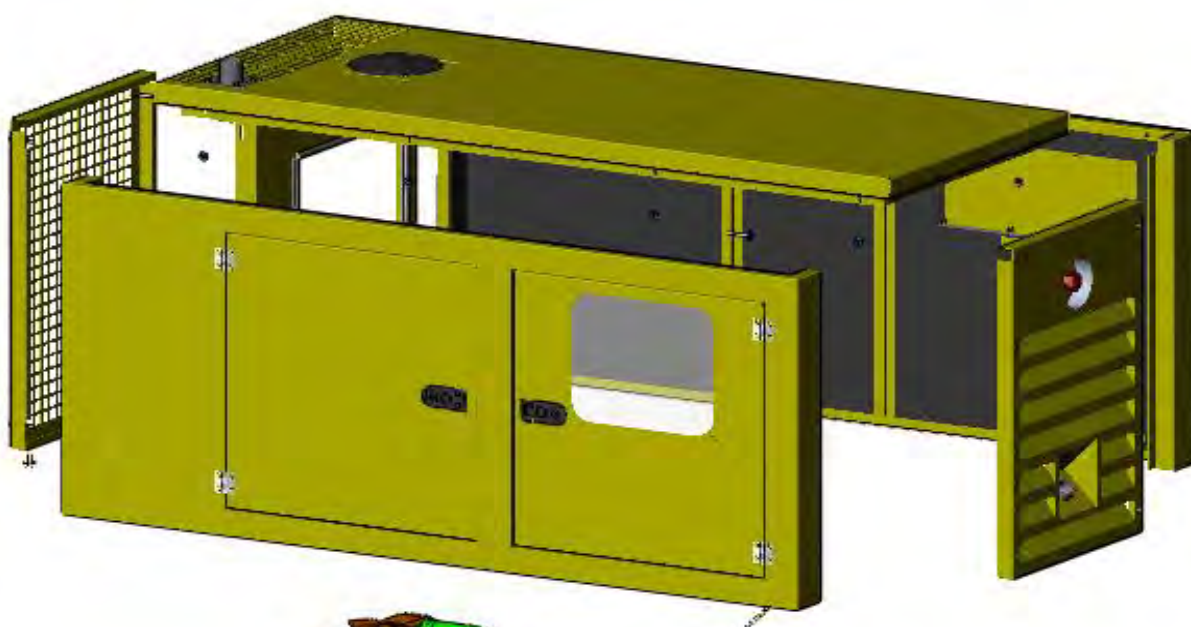
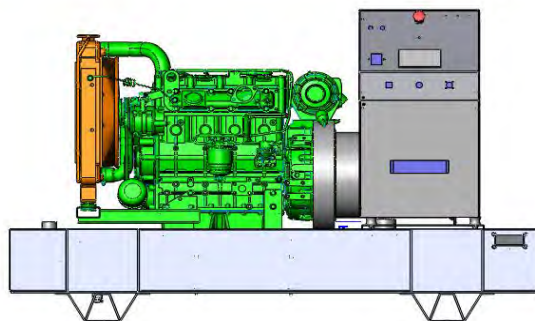

Open skid to soundproof - 1500rpm - 24h/day - 2000h/year

SOUNDPROOF GENERATORS - 1500rpm - 24h/day - 2000h/year



1 ~

3 ~

1500
RPM

50
HERTZ

SOUNDPROOF GENERATORS - 1500rpm - 24h/day - 2000h/year



SOUNDPROOF GENERATORS = SINGLE-PHASE 1500R.P.M.

50 HERTZ

1500 RPM

G5	GENERATORS TARIF 50Hz					
C	CONTINUOUS 1500rpm 24h/day --- 2000h/year <i>ENGINE</i>			I	SOUNDPROOF <i>COOLING SYSTEM</i>	
L/D	L Lister-Petter	W/O		W	Agua (Water)	
	D Deutz			O	Aceite (Oil)	
RC	Manual - Remote panel			A Automatic AMF panel		

KVA	Technical data	M9 C1	M13 C1	M16 C1	M21 C1	M31	M42	KVA
TECHNICAL DATA	Compliance emissions 2002/88	Exempt	Exempt	Exempt	YES	YES	YES	TECHNICAL DATA
	Compliance noise 2000/14/CE	YES	YES	YES	YES	YES	YES	
	Stand-by power/Continuous power [kVA]	9 / 8	13 / 11	16 / 14	20,6 / 18	30,5 / 28	42 / 38	
	Voltage [V] / Intensity [A] / Cos φ	230/39/0,9	230/56/0,9	230/69/0,9	230/91/0,9	230/132/0,9	230/180/0,9	
	Dimensions length x width x height [mm]	1800/740/1170	1800/740/1170	1800/740/1170	1800/740/1170	2200/1000/1260	2200/1000/1260	
	Dim packaging length x width x height [mm]	1800/750/1170	1800/750/1170	1800/750/1170	1800/750/1170	2230/1080/1260	2230/1080/1260	
	Acoustic power LWA [dBA]	87	87	89	86	94	94	
	Acoustic pressure LPA [dBA] 16m/10m/7m/4m	55/59/62/67	55/59/62/67	57/61/64/69	54/58/61/66	62/66/69/74	62/66/69/74	
	Fuel tank [l] / Autonomy 75% (PRP) [h]	50 / 33	50 / 23	50 / 17	50 / 12,5	80 / 14	80 / 11	
	Units per container 20' / 40'	9 / 19	9 / 19	9 / 19	9 / 19	5 / 10	5 / 10	

ALT	Alternator code	18798	18803	18802	14229	1134	642	ALT
	Model	LSA 40 VS2	LSA 40 S4	LSA 40 L7	LSA 42.2 L9	LSA 43.2 S15	LSA 43.2 M45	
	Manufacturer	LEROY SOMER	LEROY SOMER	LEROY SOMER	LEROY SOMER	LEROY SOMER	LEROY SOMER	
	Regulation	AVR	AVR	AVR	AVR	AVR	AVR	
	Protection index IP	IP23	IP23	IP23	IP23	IP23	IP23	

ENGINE	Engine code	12531	12536	12535	18476	DEU-0020	DEU-0021	ENGINE
	Model	LPW2	LPW3	LPW4	D2009L04	F4M2011	BF4M2011	
	Manufacturer	LISTER	LISTER	LISTER	DEUTZ	DEUTZ	DEUTZ	
	Coupling	SAE5 7½	SAE5 7½	SAE5 7½	SAE5 7½	SAE3 11½	SAE3 11½	
	Cooling system / N° cylindres /Aspiration	Water/2/Nat	Water/3/Nat	Water/4/Nat1	Water/4/Turbo	Oil/4/Natural	Oil/4/Turbo	

RC	Manual - Remote panel	G5 CILW	G5 CILW	G5 CILW	G5 CIDW	G5 CIDO	G5 CIDO	RC
	Generator code	M9C1 RC	M13C1 RC	M16C1 RC	M21C1 RC	M31 RC	M42 RC	
	Retail price	6.950 €	7.685 €	8.566 €	9.800 €	11.705 €	13.091 €	
	Net weight / With Packaging [kg]	498 / 507	7570	619 / 628	715 / 730	925 / 935	975 / 985	
	Control panel type	Manual-Remote	Manual-Remote	Manual-Remote	Manual-Remote	Manual-Remote	Manual-Remote	

RC	Controller CPU	GPM3	GPM3	GPM3	GPM3	GPM3	GPM3	RC
	Engine panel / Engine wiring harness	16169/129	16169/129	16169/129	16169/18526	16777/226	16777/226	
	Power control panel / Power wiring harness	2652/908	2545/890	2668/890	2 / 544	1633/440	16433/440	
	Generator code	2675	2626	2629	18815	836	15347	
	Retail price	7.050 €	7.750 €	8.590 €	9.700 €	11.773 €	13.105 €	

AMF	Control panel type	Automatic AMF	Automatic AMF	Automatic AMF	Automatic AMF	Automatic AMF	Automatic AMF	AMF
	Controller CPU	GECO MD	GECO MD	GECO MD	GECO MD	GECO MD	GECO MD	
	Engine panel / Engine wiring harness	14840 / 129	14840/129	14840/129	14840 / 18526	16782/226	16782/226	
	Power control panel / Power wiring harness	2656/908	2581/890	2676/890	797 / 544	12902/440	16432/440	
	Kit maint 1000 h ENGINE	2276 / 108€	2278 / 116€	2278 / 116€	CONSULTAR	DEU-1090 / 116€	DEU-1090 / 116€	

KITS	Kit maint/emerg 1000 h ENGINE	2277 / 143€	2279 / 143€	2279 / 143€	CONSULTAR	DEU-1098 / 133€	DEU-1101 / 133€	KITS	
	Options	Available options (Code / Retail price)							
	ALT	LSA: Leroy Somer alternator	SERIE	SERIE	SERIE	SERIE	SERIE		ALT
	ATS	1ATS: Integrated ATS for RC models	N.A.	N.A.	N.A.	N.A.	N.A.		ATS
	Panel	GPM3: GPM3 digital controller for RC models	SERIE	SERIE	SERIE	SERIE	SERIE		Panel

Engine	EMR-A: Engine electronic governor for A	N.A.	N.A.	N.A.	N.A.	15209 / 810€	14892 / 810€	Engine
	EMR-RC: Engine electronic governor for RC	N.A.	N.A.	N.A.	N.A.	15209 / 810€	14892 / 810€	
	EMR-BUS: Engine MODBUS (needs AMF25)	N.A.	N.A.	N.A.	N.A.	15349 / 315€	15349 / 315€	
	AIRCALD: Air pre-heating for RC models	19156 / 70€	19156 / 70€	19156 / 70€	N.A.	19157 / 145€	SERIE	
	AIRCALD: Air pre-heating for A models	19158 / 75€	19158 / 75€	19158 / 75€	N.A.	19159 / 150€	SERIE	

Inst	RESID: Residential muffler	SERIE	SERIE	SERIE	SERIE	SERIE	SERIE	Inst
	2,5FLEX50 (LISTER) / Ø60 (DEUTZ)	...934-032/55€	...934-032/55€	...934-032/55€	...934-032/55€	12874 / 57€	12874 / 57€	
	5FLEX50 (LISTER) / Ø60 (DEUTZ)	...934-033/93€	...934-033/93€	...934-033/93€	...934-033/93€	12875 / 98€	12875 / 98€	
	CAPOT: Open canopy (Consult us)	16935/ -500€	16936/ -500€	16938/ -500€	16938/ -500€	N.A.	N.A.	
	C.OBRA: Not approved trailer	15518 / 920€	15518 / 920€	15518 / 920€	15518 / 920€	xxx/1056€	xxx/1056€	

Trailer	C.HOMOL: Approved trailer (In Spain)	15519 / 1700€	15519 / 1700€	15519 / 1700€	15519 / 1700€	XXX/2289€	XXX/2289€	Trailer
	C.ART: Articulated rod	Consult us	Consult us	Consult us	Consult us	Consult us	Consult us	
	C.ARG: O-hitch or ballmounted coupling	SERIE	SERIE	SERIE	SERIE	Consult us	Consult us	
	B.RETEN: 110% liquids retention tray	SERIE	SERIE	SERIE	SERIE	12823 / 500€	12823 / 500€	
	B.SOLD: Internally welded retention tray	SERIE	SERIE	SERIE	SERIE	15692 / 124€	15692 / 124€	

Fuel	DECCOMB: Fuel decanter filter or pre-filter	SERIE	SERIE	SERIE	SERIE	15970 / 361€	15970 / 361€	Fuel
	190L (C1): 250L (C2): 420L (M31-M42)	13493/273€	13493/273€	13493/273€	13493/273€	3175 / 522€	3175 / 522€	
	B-TR-MN: Semi-Automatic fuel electropump	N.A.	N.A.	N.A.	N.A.	3046 / 500€	3046 / 500€	
	B-TR-AU: Automatic fuel electropump	N.A.	N.A.	N.A.	N.A.	12488 / 542€	12488 / 542€	
	Options	Available options (Code / Retail price)						



SOUNDPROOF GENERATORS = THREE-PHASE 1500R.P.M.

50
HERTZ
1500
RPM

G5	GENERATORS TARIF 50Hz			
C	CONTINUOUS 1500rpm 24h/día --- 2000h/año		I	SOUNDPROOF
L/D	L	Lister-Petter	W/O	COOLING SYSTEM W Agua (Water) O Aceite (Oil)
	D	Deutz		
RC	Manual-Remote panel		A Automatic AMF panel	

KVA	Technical data	M55 C2	T10 C1	T15 C1	T20 C1	T25 C1	T35	KVA
TECHNICAL DATA	Compliance emissions 2002/88	YES	Exempt	Exempt	Exempt	YES	YES	TECHNICAL DATA
	Compliance noise 2000/14/CE	YES	YES	YES	YES	YES	YES	
	Stand-by power/Continuous power [kVA]	55 / 49	10 / 9	14 / 12,5	19,5 / 17,5	25 / 23	35 / 31,5	
	Voltage [V] / Intensity [A] / Cos φ	230 / 239 / 0,9	400 / 14 / 0,8	400 / 21 / 0,8	400 / 28 / 0,8	400 / 36 / 0,8	400 / 50 / 0,8	
	Dimensions length x width x height [mm]	2250/950/1292	1800/740/1170	1800/740/1170	1800/740/1170	1800/740/1170	2200/1000/1260	
	Dim packaging length x width x height [mm]	2300/1000/1300	1800/750/1170	1800/750/1170	1800/750/1170	1800/750/1170	2230/1080/1260	
	Acoustic power LWA [dBA]	89	87	87	89	86	94	
ENGINE	Acoustic pressure LPA [dBA] 16m/10m/7m/4m	57/61/64/69	55/59/62/67	55/59/62/67	57/61/64/69	54/58/61/66	62/66/69/74	ENGINE
	Fuel tank [l] / Autonomy 75% (PRP) [h]	100 / 9,5	50 / 33	50 / 23	50 / 17	50 / 12,5	80 / 14	
	Units per container 20' / 40'	6 / 12	9 / 19	9 / 19	9 / 19	9 / 19	6 / 12	
	Engine code	18150	12531	12536	12535	18476	DEU-0020	
	Model	BF4M2011C	LPW2	LPW3	LPW4	D2009L04	F4M2011	
	Manufacturer	DEUTZ	LISTER	LISTER	LISTER	DEUTZ	DEUTZ	
	Cooling system / N° cylindres /Aspiration	Oil/4/Turbo	Water/2/Nat	Water/3/NatI	Water/4/Nat	Water/4/Turbo	Oil/4/Nat	
RC	Manual - Remote panel	G5 CIDO	G5 CILW	G5 CILW	G5 CILW	G5 CIDW	G5 CIDO	RC
	Generator code	M55C2 RC	T10C1 RC	T15C1 RC	T20C1 RC	T25C1 RC	T35 RC	
	Retail price	15.990 €	6.800 €	7.377 €	8.250 €	9.348 €	11.367 €	
	Net weight / With packaging [kg]	1220 / 1235	500 / 510	550 / 560	650 / 665	690 / 700	841 / 851	
ALT	Generator code	18515	2093	2095	2096	18359	GED0509	ALT
	Alternator code	207	18805	18798	18803	18802	1151	
	Model	LSA 43.2 L8	LSA 40 VS1	LSA 40 VS2	LSA 40 S4	LSA 40 L7	LSA 42.2 L9	
	Manufacturer	LEROY SOMER	LEROY SOMER	LEROY SOMER	LEROY SOMER	LEROY SOMER	LEROY SOMER	
	Regulation	AVR	AVR	AVR	AVR	AVR	AVR	
	Protection index IP	IP23	IP23	IP23	IP23	IP23	IP23	
	Control panel type	Manual-Remote	Manual-Remote	Manual-Remote	Manual-Remote	Manual-Remote	Manual-Remote	
RC	Controller CPU	GPM3	GPM3	GPM3	GPM3	GPM3	GPM3	RC
	Engine panel / Engine wiring harness	16169/129	16169/129	16169/129	16169/129	16169/18526	16778/226	
	Power control panel / Power wiring harness	14785/1729	14785/1729	3245/1729	1723/1711	1723 / 1711	1878/1658	
	Generator code	M55C2 A	T10C1 A	T15C1 A	T20C1 A	T25C1 A	T35 A	
A	Retail price	15.750 €	6.990 €	7.500 €	8.317 €	9.602 €	11.551 €	A
	Net weight / With packaging [kg]	1220 / 1235	500 / 510	550 / 560	650 / 665	690 / 700	841 / 851	
	Alternator code	207	18805	18798	18803	18802	1151	
	Model	LSA 43.2 L8	LSA 40 VS1	LSA 40 VS2	LSA 40 S4	LSA 40 L7	LSA 42.2 L9	
AMF	Manufacturer	LEROY SOMER	LEROY SOMER	LEROY SOMER	LEROY SOMER	LEROY SOMER	LEROY SOMER	AMF
	Regulation	AVR	AVR	AVR	AVR	AVR	AVR	
	Protection index IP	IP23	IP23	IP23	IP23	IP23	IP23	
	Control panel type	Automatic AMF	Automatic AMF	Automatic AMF	Automatic AMF	Automatic AMF	Automatic AMF	
	Controller CPU	GECO MD	GECO MD	GECO MD	GECO MD	GECO MD	GECO MD	
	Engine panel / Engine wiring harness	14840/129	14840/129	14840/129	14840/129	14840 / 18526	16781/226	
	Power control panel / Power wiring harness	16214/1729	16214/1729	3245/1729	1723/1711	1723 / 1711	1895/1658	
KITS	Kit maint 1000 h ENGINE	DEU-1090/116€	2276 / 108€	2278 / 116€	2278 / 116€	CONSULTAR	DEU-1090/116€	KITS
	Kit maint/emerg 1000 h ENGINE	DEU-1101/135€	2277 / 143€	2279 / 143€	2279 / 143€	CONSULTAR	DEU-1098/133€	
Options	<i>Available options (Code / Retail price)</i>							Options
ALT	LSA: Leroy Somer alternator	SERIE	SERIE	SERIE	SERIE	SERIE	SERIE	ALT
	LSA-TR: Leroy Somer tropicalized	XXXXX / 271€	XXXXX / 271€	XXXXX / 271€	XXXXX / 271€	XXXXX / 271€	14175 / 271€	
	LSA-PMG: Leroy Somer PMG system	Consult us	Consult us	Consult us	Consult us	Consult us	Consult us	
	LSACALD: Leroy Somer with preheating	XXXXX / 203€	XXXXX / 203€	XXXXX / 203€	XXXXX / 203€	XXXXX / 162€	14251 / 162€	
ATS	1ATS: Integrated ATS for RC models	Consult us	N.A.	N.A.	N.A.	N.A.	N.A.	ATS
	1ATS: Separated ATS for RC models	Consult us	1976 / 170€	1976 / 170€	1976 / 170€	1976 / 170€	1989 / 294€	
	2ATS: Separated ATS for A models	Consult us	1977 / 212€	1977 / 212€	1977 / 212€	1977 / 212€	1999 / 479€	
Panel	TEMP: Automatic start/stop clock for RC	3017 / 131€	3017 / 131€	3017 / 131€	3017 / 131€	3017 / 131€	3017 / 131€	Panel
	220V: Output voltage 220V for RC models	N.A.	15400 / 20€	15393 / 58€	15395 / 54€	15383 / 74€	15398 / 280€	
	220V: Output voltage 220V for A models	N.A.	15401 / 16€	15394 / 42€	15396 / 58€	15386 / 102€	15399 / 102€	
	GPM2: GM2 controller (A+V/A+F/V+F)	N.A.	N.A.	N.A.	N.A.	N.A.	N.A.	
	GPM3: GPM3 digital controller for RC models	SERIE	SERIE	SERIE	SERIE	SERIE	SERIE	
	GECO-MD: GECOMD digital for A models	SERIE	SERIE	SERIE	SERIE	SERIE	SERIE	
	AMF25: AMF25 digital for A with EMR	15023 / 161€	15023 / 161€	15023 / 161€	15023 / 161€	15343 / 161€	15343 / 161€	
	PROTDIF: Differential protection A models	N.A.	15437 / 76€	15438 / 73€	15439 / 80€	15467 / 121€	15468 / 119€	
	BASES: Shokets for RC models	N.A.	15145 / 118€	15145 / 118€	15145 / 118€	16014 / 200€	16015 / 200€	
	DESCBAT: Battery disconnecter	15345 / 88€	15345 / 88€	15345 / 88€	15345 / 88€	15345 / 88€	15345 / 88€	
Engine	VDO: Press & Temp transmitt. (GPM3/AMF25)	15967 / 130€	15965 / 88€	15965 / 88€	15965 / 88€	18803 / 250€	15967 / 130€	Engine
	EMR-A: Engine electronic governor for A	CONSULTAR	N.A.	N.A.	N.A.	N.A.	15209 / 810€	
	EMR-RC: Engine electronic governor for RC	CONSULTAR	N.A.	N.A.	N.A.	N.A.	15209 / 810€	
	EMR-BUS: Engine MODBUS (needs AMF25)	CONSULTAR	15349 / 325€	15349 / 325€	15349 / 325€	N.A.	15349 / 325€	
	AIRCALD: Air pre-heating for RC models	SERIE	19156 / 70€	19156 / 70€	19156 / 70€	N.A.	19157 / 145€	
	AIRCALD: Air pre-heating for A models	SERIE	19158 / 75€	19158 / 75€	19158 / 75€	N.A.	19159 / 150€	
	LIQCALD: Liquid pre-heating	N.D.	13086 / 482€	13086 / 482€	13086 / 482€	13081 / 411€	N.A.	
Inst	RESID: Residential muffler	SERIE	SERIE	SERIE	SERIE	SERIE	SERIE	Inst
	2_5FLEX50 (LISTER) / Ø60 (DEUTZ)	Consult us	...934-032/55€	...934-032/55€	...934-032/55€	...934-032/55€	12874 / 57€	
	5FLEX50 (LISTER) / Ø60 (DEUTZ)	Consult us	...934-033/92€	...934-033/92€	...934-033/92€	...934-033/92€	12875 / 98€	
	CAPOT: Open canopy (Consult us)	Consult us	16935/ -500€	16936/ -500€	16938/ -500€	16938/ -500€	N.A.	
Trailer	C.OBRA: Not approved trailer	Consult us	1Axle / Ball 15518 / 920€	1Axle / Ball 15518 / 920€	1Axle / Ball 15518 / 920€	1Axle / Ball 15518 / 920€	1Axle / Ball 956/1056€	Trailer
	C.HOMOL: Approved trailer (In Spain)	Consult us	1Axle / Ball 15519 / 1700€	1Axle / Ball 15519 / 1700€	1Axle / Ball 15519 / 1700€	1Axle / Ball 15519 / 1700€	2413/2289€	
	C.ART: Articulated rod	Consult us	Consult us	Consult us	Consult us	Consult us	15336 / 346€	
	C.ARG: O-hitch or ballmounted coupling	Consult us	Consult us	Consult us	Consult us	Consult us	15335 / 40€	
	B.RETEN: 110% liquids retention tray	SERIE	SERIE	SERIE	SERIE	SERIE	12823 / 500€	
Fuel	B.SOLD: Internally welded retention tray	SERIE	SERIE	SERIE	SERIE	SERIE	15692 / 124€	Fuel
	DECCOMB: Fuel decanter filter or pre-filter	15970 / 361€	SERIE	SERIE	SERIE	SERIE	15970 / 361€	
	190L (C1): 250L (C2): 420L (T35)	Consult us	13493 / 273€	13493 / 273€	13493 / 273€	13493 / 273€	3175 / 522€	
	B-TR-MN: Semi-Automatic fuel electropump	3046 / 500€	N.A.	N.A.	N.A.	N.A.	3046 / 500€	
B-TR-AU: Automatic fuel electropump	12488 / 543€	N.A.	N.A.	N.A.	N.A.	12488 / 543€		



Foto: 65 CIDO T35 RC (CON C.HOMOL)

SOUNDPROOF GENERATORS = THREE-PHASE 1500RPM

G5 GENERATORS TARIF 50Hz

50 HERTZ

1500 RPM

C	CONTINUOUS 1500rpm 24h/day --- 2000h/year		I	SOUNDPROOF	
	ENGINE			COOLING SYSTEM	
L/D	L	Lister-Petter	W/O	W	Agua (Water)
	D	Deutz		O	Aceite (Oil)
RC	Manual-Remote panel		A Automatic AMF panel		

KVA	Technical data	T35 C2	T47	T47 C2	T65 C2	T100	T115	KVA
TECHNICAL DATA	Compliance emissions 2002/88	YES	YES	YES	YES	NO	YES	TECHNICAL DATA
	Compliance noise 2000/14/CE	YES	YES	YES	YES	NO	NO	
	Stand-by power/Continuous power [KVA]	35 / 31,5	47 / 40	47 / 40	65 / 58	100 / 90	115 / 104	
	Voltage [V] / Intensity [A] / Cos φ	400 / 50 / 0,8	400 / 67 / 0,8	400 / 93 / 0,8	400 / 93 / 0,8	400 / 145 / 0,8	400 / 166/ 0,8	
	Dimensions length x width x height [mm]	2250/950/1292	2200/1000/1260	2250/950/1292	2250/950/1292	3000/1100/1480	3000/1100/1480	
	Dim packaging length x width x height [mm]	2300/1000/1300	2200/1080/1260	2250/950/1300	2250/950/1300	3050/1130/1480	3050/1130/1480	
	Acoustic power LWA [dBA]	90	94	90	89	99	101	
	Acoustic pressure LPA [dBA] 16m/10m/7m/4m	58/62/65/70	62/66/69/74	58/62/65/70	57/62/64/69	67/71/74/79	69/73/76/81	
	Fuel tank [l] / Autonomy 75% (PRP) [h]	100 / 17	80 / 11	100 / 13,5	100 / 9,5	150 / 10	150 / 8	
	Units per container 20' / 40'	6 / 12	5 / 10	6 / 12	6 / 12	2 / 6	2 / 6	
ALT	Alternator code	1151	1134	642	642	392	392	ALT
	Model	LSA 42.2 L9	LSA43.2S15	LSA43.2M45	LSA43.2M45	LSA44.2VS45	LSA44.2VS45	
	Manufacturer	LEROY SOMER	LEROY SOMER	LEROY SOMER	LEROY SOMER	LEROY SOMER	LEROY SOMER	
	Regulation	AVR	AVR	AVR	AVR	AVR	AVR	
	Protection index IP	IP23	IP23	IP23	IP23	IP23	IP23	
ENGINE	Engine code	DEU-0020	DEU-0021	18150	18150	999	714	ENGINE
	Model	F4M2011	BF4M2011	BF4M2011C	BF4M2011C	BF4M1013E	BF4M1013EC	
	Manufacturer	DEUTZ	DEUTZ	DEUTZ	DEUTZ	DEUTZ	DEUTZ	
	Coupling	SAE3 11½	SAE3 11½	SAE3 11½	SAE3 11½	SAE2 11½	SAE2 11½	
	Cooling system / N° cylindres /Aspiration	Oil/4/Natural	Oil/4/Turbo	Oil/4/Turbo	Oil/4/Turbo	Water/4/Turbo	Water/4/Turbo	
RC	Manual - Remote panel	G5 CIDO T35C2 RC	G5 CIDO T47 RC	G5 CIDO T47C2 RC	G5 CIDO T65C2 RC	G5 CIDW T100 RC	G5 CIDW T115 RC	RC
	Generator code	17846	12386	18093	17889	1020	1023	
	Retail price	11.890 €	12.386 €	12.815 €	14.785 €	18.169 €	19.656 €	
	Net weight / With packaging [kg]	1050 / 1065	945 / 955	1250 / 1275	1150 / 1185	1430 / 1435	1490 / 1500	
RC	Control panel type	REMOTO-CEE	REMOTO-CEE	REMOTO-CEE	REMOTO-CEE	REMOTO-CEE	REMOTO-CEE	RC
	Controller CPU	GPM3	GPM3	GPM3	GPM3	GPM3	GPM3	
	Engine panel / Engine wiring harness	16169/226	16778/226	14854/226	16169/226	16778/646	16777/646	
	Power control panel / Power wiring harness	1665/1668	1900/1668	1682/1668	1682/1668	1916/1694	1925/1755	
A	Automatic Mains Failure AMF panel	G5 CIDO T35C2 A	G5 CIDO T47 A	G5 CIDO T47C2 A	G5 CIDO T65C2 A	G5 CIDW T100 A	G5 CIDW T115 A	A
	Generator code	18056	GED0579	18094	18092	1022	1025	
	Retail price	11.950 €	12.501 €	12.950 €	14.671 €	18.175 €	19.616 €	
	Net weight / With packaging [kg]	1050 / 1065	945 / 955	1250 / 1275	1150 / 1185	1430 / 1440	1490 / 1500	
AMF	Control panel type	CAIDA RED/AMF	CAIDA RED/AMF	CAIDA RED/AMF	CAIDA RED/AMF	CAIDA RED/AMF	CAIDA RED/AMF	AMF
	Controller CPU	GECO MD	GECO MD	GECO MD	GECO MD	GECO MD	GECO MD	
	Engine panel / Engine wiring harness	14840 / 226	16781/226	14840 / 226	14840 / 226	15480/646	16782/646	
	Power control panel / Power wiring harness	1680 / 1668	1902/1668	1684 / 1668	1684 / 1668	1922/1694	1930/1755	
KITS	Kit mant 1000 h Engine	DEU-1090/116€	DEU-1090/116€	DEU-1090/116€	DEU-1090/116€	DEU-1114/161€	DEU-1114/ 161€	KITS
	Kit mant/emerg 1000 h Engine	DEU-1098/133€	DEU-1101/135€	DEU-1101 / 135€	DEU-1101 / 135€	DEU-1115/272€	DEU-1115/ 272€	
Options	Available options (Code / Retail price)							Options
ALT	LSA: Leroy Somer alternator	SERIE	SERIE	SERIE	SERIE	SERIE	SERIE	ALT
	LSA-TR: Leroy Somer tropicalized	14175 / 271€	14176 / 271€	14176 / 271€	12419 / 271€	15309 / 280€	15309 / 280€	
	LSA-PMG: Leroy Somer PMG system	Consult us	Consult us	Consult us	Consult us	Consult us	Consult us	
	LSACALD: Leroy Somer with preheating	14251 / 162€	15153 / 215€	15153 / 215€	15489 / 215€	15155 / 215€	15155 / 215€	
ATS	1ATS: Separated ATS for RC models	1989 / 294€	1989 / 294€	1989 / 294€	1989 / 294€	3262 / 477€	3262 / 477€	ATS
	2ATS: Separated ATS for A models	1999 / 479€	1999 / 479€	1999 / 479€	1999 / 479€	3265 / 920€	3265 / 920€	
Panel	TEMP: Automatic start/stop clock for RC	3017 / 131€	3017 / 131€	3017 / 131€	3017 / 131€	3017 / 131€	3017 / 131€	Panel
	220V: Output voltage 220V for RC models	15398 / 280€	15391 / 279€	15391 / 279€	15454 / 409€	15480 / 630€	15482 / 826€	
	220V: Output voltage 220V for A models	15399 / 102€	15392 / 102€	15392 / 102€	15455 / 375€	15481 / 571€	15483 / 848€	
	GPM2: GM2 controller (A+V/A+F/V+F)	N.A.	N.A.	N.A.	N.A.	N.A.	N.A.	
	GPM3: GPM3 digital controller for RC models	SERIE	SERIE	SERIE	SERIE	SERIE	SERIE	
	GECO-MD: GECOMD digital for A models	SERIE	SERIE	SERIE	SERIE	SERIE	SERIE	
	AMF25: AMF25 digital for A with EMR	15343 / 161€	15343 / 161€	15343 / 161€	15023 / 161€	15343 / 161€	15343 / 161€	
	PROTDIF: Differential protection A models	15468 / 119€	15469 / 119€	15469 / 119€	15443 / 170€	15471 / 147€	15472 / 193€	
	BASES: Shokets for RC models	16015 / 200€	16016 / 300€	16016 / 300€	CONS	18052 / 412€	18052 / 412€	
	DESCBAT: Battery disconnecter	15345 / 88€	15345 / 88€	15345 / 88€	15345 / 88€	15345 / 88€	15345 / 88€	
Engine	VDO: Press & Temp transmitt. (GPM3/AMF25)	15967 / 130€	15967 / 130€	15967 / 130€	15967 / 130€	15968 / 140€	15968 / 140€	Engine
	EMR-A: Engine electronic governor for A	15209 / 810€	14892 / 810€	14892 / 810€	XXXX / 810€	15217 / 1107€	15218 / 1107€	
	EMR-RC: Engine electronic governor for RC	15209 / 810€	14892 / 810€	14892 / 810€	XXXX / 810€	15217 / 1107€	15218 / 1107€	
	EMR-BUS: Engine MODBUS (needs AMF25)	15349 / 325€	15349 / 325€	15349 / 325€	15349 / 325€	15349 / 325€	15349 / 325€	
	AIRCALD: Air pre-heating for RC models	19157 / 145€	SERIE	SERIE	SERIE	N.A.	N.A.	
	AIRCALD: Air pre-heating for A models	19159 / 150€	SERIE	SERIE	SERIE	N.A.	N.A.	
	LIQCALD: Liquid pre-heating	N.A.	N.A.	N.A.	N.A.	13081 / 411€	13081 / 411€	
Inst	RESID: Residential muffler	SERIE	SERIE	SERIE	SERIE	SERIE	SERIE	Inst
	2.5FLEX60 (T35-T47) / Ø100 (T70-T150)	12874 / 57€	12874 / 57€	12874 / 57€	12874 / 57€	15324 / 85€	15324 / 85€	
	5FLEX60 (T35-T47) / Ø100 (T70-T150)	12875 / 98€	12875 / 98€	12875 / 98€	12875 / 98€	15325 / 162€	15325 / 162€	
Trailer	C.OBRA: Not approved trailer	Consult us	956 / 1056€	956 / 1056€	Consult us	1339 / 1211€	1339 / 1211€	Trailer
	C.HOMOL: Approved trailer (In Spain)	Consult us	2413 / 2289€	2413 / 2289€	Consult us	1326 / 3925€	1326 / 3925€	
	C.ART: Articulated rod	Consult us	Consult us	Consult us	Consult us	Consult us	Consult us	
	C.ARG: O-hitch or ballmounted coupling	Consult us	Consult us	Consult us	Consult us	Consult us	Consult us	
	B.RETEN: 110% liquids retention tray	SERIE	12823 / 500€	SERIE	SERIE	12825 / 836€	12825 / 836€	
Fuel	B.SOLD: Internally welded retention tray	SERIE	15692 / 124€	SERIE	SERIE	15694 / 201€	15694 / 201€	Fuel
	DECCOMB: Fuel decanter	15970 / 361€	15970 / 361€	15970 / 361€	15970 / 361€	SERIE	SERIE	
	190L (C1): 250L (C2): 420L (T35)	18158 / 350€	3175 / 522€	18158 / 350€	18158 / 350€	3177 / 645€	3177 / 645€	
	B-TR-MN: Semi-Automatic fuel electropump	3046 / 500€	3046 / 500€	3046 / 500€	3046 / 500€	3046 / 500€	3046 / 500€	
	B-TR-AU: Automatic fuel electropump	12488 / 542€	12488 / 542€	12488 / 542€	12488 / 542€	12488 / 542€	12488 / 542€	

3 ~



SOUNDPROOF GENERATORS = THREE-PHASE 1500rpm

G5 GENERATORS TARIF 50HZ

C CONTINUOUS 1500rpm 24h/día --- 2000h/año **I** SOUNDPROOF **ENGINE** **COOLING SYSTEM**

D D Deutz **W** W Agua (Water)

RC Manual-Remote panel **A** Automatic AMF panel

50 HERTZ

1500 RPM

KVA	Datos técnicos RC / A	T140	T175	T200	T275	KVA
TECHNICAL DATA	Compliance emissions 2002/88	YES	YES	YES	YES	TECHNICAL DATA
	Stand-by power/Continuous power [kVA]	140 / 125	175 / 157	200 / 180	275 / 250	
	Voltage [V] / Intensity [A] / Cos φ	400 / 200 / 0,8	400 / 250 / 0,8	400 / 290 / 0,8	400 / 396 / 0,8	
	Dimensions length x width x height [mm]	3000/1100/1480	3500/1100/1480	3550/1330/2000	3550/1330/2000	
	Dim packaging length x width x height [mm]	3050/1130/1480	3500/1100/1480	3550/1330/2000	3550/1330/2000	
	Acoustic power LWA [dBA]	103	108	108	104	
	Acoustic pressure LPA [dBA] 16m/10m/7m/4m	71/75/78/83	76/80/83/88	76/80/83/88	72/76/79/84	
Fuel tank [l] / Autonomy 75% (PRP) [h]	150 / 6	150 / 6	330 / 10	330 / 8		
Units per container 20' / 40'	2 / 6	2 / 6	1 / 3	1 / 3		
ALT	Alternator code	639	2121	13724	407	ALT
	Model	LSA 44.2 S75	LSA44.2L12	LSA46.2M3	LSA46.2L6	
	Manufacturer	LEROY SOMER	LEROY SOMER	LEROY SOMER	LEROY SOMER	
	Regulation	AVR	AVR	AVR	AVR	
	Protection index IP	IP23	IP23	IP23	IP23	
ENGINE	Engine code		2853	13834	14482	ENGINE
	Model	BF4M1013FC	BF6M1013EC/8	BF6M1013FCP/8	TCD2013L064/8	
	Electronic governor (Accuracy= ±0%)	EMR2 type	As option	EMR2 type	EMR3 type	
	Manufacturer	DEUTZ	DEUTZ	DEUTZ	DEUTZ	
	Coupling	SAE2 11½	SAE2 11½	SAE2 11½	SAE2 11½	
	Cooling system / N°cylinders / Aspiration	Water/4/Turbo	Water/6/Turbo	Water/6/Turbo	Water/6/C.Rail	
RC	Manual - Remote panel	G5 CIDW T140 RC	G5 CIDW T175 RC	G5 CIDW T200 RC	G5 CIDW T275 RC	RC
	Generator code	17499	14723	14264	14415	
	Retail price	21.760 €	25.844 €	31.453 €	33.738 €	
	Net weight / With packaging [kg]	1800 / 1820	2350 / 2370	2400 / 2420	2600 / 2630	
RC	Control panel type	Manual-Remote	Manual-Remote	Manual-Remote	Manual-Remote	RC
	Controller CPU	GPM3	GPM3	GPM3	GPM3	
	Engine panel / Engine wiring harness	16779/18472	16777/18472	16779/3064	16779/14699	
	Power control panel / Power wiring harness	3255/2417	3255/2417	2897/2417	2897/1755	
A	Automatic Mains Failure AMF panel	G5 CIDW T140 A	G5 CIDW T175 A	G5 CIDW T200 A	G5 CIDW T275 A	A
	Generator code	18479	3650	14265	14416	
	Retail price	21.990 €	25.715 €	31.338 €	33.627 €	
	Net weight / With packaging [kg]	1800 / 1825	2375 / 2395	2400 / 2420	2600 / 2630	
AMF	Control panel type	Automatic AMF	Automatic AMF	Automatic AMF	Automatic AMF	AMF
	Controller CPU	GECO MD	GECO MD	GECO MD	GECO MD	
	Engine panel / Engine wiring harness	16783/2973	16782/2973	16783/3064	167774 / 14699	
	Power control panel / Power wiring harness	2439/2417	2439/2417	15029/2417	16092 / 1755	
KITS	Kit mant 1000 h Engine	Consult us	DEU-1117/203€	DEU-1119/217€	15495 / 658€	KITS
	Kit mant/emerg 1000 h Engine	Consult us	DEU-1118/315€	DEU-1120/328€	15329 / 769€	
Options	Available options (Code / Retail price)				Options	
ALT	LSA: Leroy Somer alternator	SERIE	SERIE	SERIE	SERIE	ALT
	LSA-TR: Leroy Somer tropicalized	15310 / 280€	15311 / 280€	15312 / 309€	15313 / 309€	
	LSA-PMG: Leroy Somer PMG system	Consult us	Consult us	Consult us	Consult us	
	LSACALD: Leroy Somer with preheating	15491 / 215€	15492 / 215€	15493 / 215€	15494 / 215€	
ATS	1ATS: Separated ATS for RC models	3262 / 477€	3262 / 477€	2982 / 827€	15348/1000€	ATS
	2ATS: Separated ATS for A models	3265 / 920€	3265 / 920€	12956/ 1644€	12956/1644€	
Panel	TEMP: Automatic start/stop clock for RC	3017 / 131€	3017 / 131€	3017 / 131€	3017 / 131€	Panel
	GPM2: GPM2 controller (A+V/A+F/V+F)	N.A.	N.A.	N.A.	N.A.	
	GPM3: GPM3 digital controller for RC models	SERIE	SERIE	SERIE	SERIE	
	GECO-MD: GECOMD digital for A models	SERIE	SERIE	SERIE	SERIE	
	AMF25: AMF25 digital for A with EMR	15343 / 161€	15343 / 161€	15343 / 161€	15343 / 161€	
	PROTDIF: Differential protection A models	15473 / 182€	15474 / 182€	15477 / 288€	15478 / 288€	
	BASES: Shokets for RC models	18052 / 412€	18052 / 412€	18052 / 412€	18052 / 412€	
	DESCBAT: Battery disconnecter	15345 / 88€	15345 / 88€	15345 / 88€	15345 / 88€	
	VDO: Press & Temp transmitt. (GPM3/AMF25)	15968 / 140€	15968 / 140€	See EMR-BUS	See EMR-BUS	
	EMR-A: Engine electronic governor for A	SERIE	12613/1006€	SERIE	SERIE	
EMR-RC: Engine electronic governor for RC	SERIE	12613/1006€	SERIE	SERIE		
EMR-BUS: Engine MODBUS (needs AMF25)	15349/325€	15349/325€	15349/325€	15349/325€		
AIRCALD: Air pre-heating for RC models	N.A.	N.A.	N.A.	N.A.		
AIRCALD: Air pre-heating for A models	N.A.	N.A.	N.A.	N.A.		
LIQCALD: Liquid pre-heating	13081/411€	13081/411€	13081/411€	17854/411€		
Inst	RESID: Residential muffler	SERIE	SERIE	SERIE	SERIE	Inst
	2,5FLEX100 (T175) / Ø120 (T200-T275)	15324 / 85€	15324 / 85€	15326 / 122€	15326 / 122€	
Trailer	5FLEX100 (T175) / Ø120 (T200-T275)	15325 / 162€	15325 / 162€	15327 / 226€	15327 / 226€	Trailer
	C.OBRA: Not aproved trailer	2 Axles / ARG 3081/1611€	2 Axles / ARG 3081/1611€	Consult us	Consult us	
	C.HOMOL: Aproved trailer (In Spain)	2 Axles / ARG 12094/4044€	2 Axles / ARG 12094/4044€	2 Axles / ARG 15560 / 4306€	2 Axles / ARG 15560 / 4306€	
	C.ART: Articulated rod	15355 / 1017€	15355 / 1017€	CONSULTAR	CONSULTAR	
	C.ARG: O-hitch or ballmounted coupling	SERIE	SERIE	SERIE	SERIE	
Fuel	B.RETEN: 110% liquids retention tray	12826 / 927€	12826 / 927€	12771 / 1041€	12771 / 1041€	Fuel
	B.SOLD: Internally welded retention tray	15695 / 268€	15695 / 268€	15696 / 325€	15696 / 325€	
	DECCOMB: Fuel decanter	SERIE	SERIE	SERIE	SERIE	
	800L (T140-175); 850L (200-275KVA)	12965/771€	12965/771€	16380/ 771€	16380/ 771€	
	B-TR-MN: Semi-Automatic fuel electropump	3046 / 500€	3046 / 500€	3046 / 500€	3046 / 500€	
B-TR-AU: Automatic fuel electropump	12488 / 542€	12488 / 542€	12488 / 542€	12488 / 542€		

MAMA / MARA / MALW

M = Motorwelding

A = Open skid

M / R / L = Minsel / Lombardini / Lister

A / W = Air / Water (Agua)

3000 r.p.m.

4h / day

400h / year



Security & Equipment

All generators integrate the indispensable protections for the operator and load security.

All the metallic parts are connected to earth protection

Fiability

The monoblock engine-alternator and the control panel are mounted on silent-blocks insuring the insulation of all vibrations from the running

Product range

ENGINES

- MINSSEL/LOMBARDINI/LISTER diesel engines
- 4 stroke
- Air cooled (Range MAMA/MARA)
- Water cooled (Range MALW)
- Electric start 12V
- Radiator with fan (MALW)
- Decanter fuel filter (MALW)
- Mechanical governor
- Protections for mobile parts
- Dry air filter
- Lubrication forced by pump
- Muffler

WELDING ALTERNATORS

- Single phase (180A) Alternative current
- Single phase (220A) Continuous current
- Brushless (180A)
- Compound & AVR
- IP23 Protection
- T.H.D. <6%
- Voltage (180A) 45÷60V
- Voltage (220A) 65÷85V
- Usable electrode: Rutile & Acidic (180ac)
- Usable electrode: All types (220ac)
- Usable electrode: All types (300dc)
- Selector 8x2 permitting change (180A)
- Security protections of the load integrated

FRAME

- Steel tube-shaped frame (MAMA/MARA)
- Rectangular steel frame (MALW)
- Metallic fuel tank in the Engine.
- Metal Fuel tank at the bottom of the generator and independant from the frame. (MALW)
- Wheels integrated (MAMA/MARA)
- Trailers available (MALW)
- Support Slient-blocks on the ground. (MAMA/MARA)
- Paint "EPOXI" anti-oxidation
- Battery & connexion wires
- Control panel completely integrated
- Silent-blocks for the Engine and alternator

		MOTORWELDING SETS 50Hz				
180A 220A		G5	GENERATOR TARIF 50Hz		180A	
		M	MOTORWELDING 3000rpm 4h/dia -- 800h/año		220A	
		M/R/L	ENGINE	A	OPEN SKID	220A
		M	SINGLE-PHASE	E / S	ELECTRIC / SOLENOID	220A
AMP	Datos técnicos RC / A	180A	220A	300A	AMP	
TECHNICAL DATA	Power [Amp]	180A	220A	300A	TECHNICAL DATA	
	Type (Altern AC / Continuous DC)	AC	DC	DC		
	Dimensions Length/Width/Height [mm]	823/800/723	823/800/723	1450/750/1170		
	Dim.with packaging [mm]	940/840/1010	940/840/1010	1500/800/1250		
	Acoustic power LWA [dBA]	109	103	104		
	Acoustic pressure LPA [dBA] 16m/10m/7m/4m	77/81/84/89	71/75/78/83	72/76/79/84		
	Fuel tank [l] / Autonomy 75% [h]	4 / 3	18 / 8	37 / 11		
Units per container 20' / 40'	28 / 56	28 / 56	10 / 21			
WELDING	Welding code	.MTS-0016	.MTS-0015	19073	WELDING	
	Model	W180 AC	W220 DC	WS300 TDC		
	Manufacturer	SACCARDO	SACCARDO	SACCARDO		
	Regulation type	COMPOUND	COMPOUND	AVR		
	Service at 35% [A]	180	220	300		
	Service at 60% [A]	125	170	240		
	Electrode diameter [mm]	4	4 - 5	5 - 6		
	Generator power [kVA]	M5	M4	M4 / T9		
Welding protection index IP	IP23	IP23	IP23			
ENGINE	Engine code	1430-5002	.336-0030	2085	ENGINE	
	Model	M430	25LD330/0	LPW2/0		
	Manufacturer	MINSSEL	LOMBARDINI	LISTER		
	Coupling	RI Ø23	RI Ø30	SAE5 7½		
	Cooling / N° cylinders / Aspiration type	Aire / 1 / Natural	Aire / 2 / Natural	Agua / 2 / Natural		
E	Electric start with key	G5 MAMA AC180M E	G5 MARA DC220M E	G5 MALW DC300T S	E	
	Pricing	Motorwelding code	MTS-0021	2286		19093
		Retail price	2.361 €	3.898 €		5.788 €
E / S	Net weight & Gross weight (with packaging) kg	130 / 146	170 / 185	520 / 535	E / S	
	Control panel type	E = ELECTRIC	E = ELECTRIC	S = SOLENOID		
	Controller CPU / Key	LLAVE	LLAVE	LLAVE		
	Panel code	.219-3550	.219-3550	Consult us		
KITS	Panel equipment	Alarms	Alarms	Alarms & STOP	KITS	
	Temp & Press	Temp & Press	Temp & Press	Temp & Press		
KITS	Kit maint 1000 h ENGINE	1430-1150/54€	.336-1051/90€	2x14589 / 108€	KITS	
	Kit maint/emerg 1000 h ENGINE	1430-1152/82€	.336-1020/ 146€	2280 / 134€		
	Wheels for manual transport / Not aproved trailer	SERIE	SERIE	1 Axle / Ball 3487 / 844€		

SACO

Tractor Driven Generator

S = 1500rpm

A = Open skid

C = Comer (Gear box)

O= Oil

8h / day

800h / year



Security & Equipment

- All generators integrate the indispensable protections for the operator and load security..

Product range

GEAR BOX

- COMER MANUFACTURER
- RPM = 435 ÷ 460
- Relation rpm = 1:6,9 (3000rpm) 1:3,28 (1500rpm)
- Oil cooled
- Protection for mobile parts



ALTERNATOR

- Synchrionic
- Three Phase
- With brush
- Compound
- IP23 Protection
- T.H.D. <5%
- Tension precision = ±5%
- Starting high-current (Icc = 3 ÷ 4In)

FRAME/CONTROL PANEL

- Steel tube-shaped frame
- Bases
- Magnetothermic
- Voltmetre
- Frecuency meter
- Differential



		TRACTOR DRIVE GENERATORS						
SACO20 SACO25 SACO30 SACO42 SACO62 SACO72		G5	GENERATOR TARIF 50HZ					
		S	S = 1500RPM		A	OPEN SKID		
		C	GEAR BOX		O	COOLING SYSTEM		
			c	COMER		o	OIL	
		T	THREE-PHASE		C	CEE (With all necessary protection devices)		
KVA	Technical data	SACO T20	SACO T25	SACO T30	SACO T42	SACO T62	SACO T72	KVA
TECHNICAL DATA	Power [KVA]	20 / 18	25 / 22	30 / 27	42 / 38	62 / 55	72 / 65	TECHNICAL DATA
	Tensión [V] / Intensidad [A] / Cos φ	400 // 0,8	400 // 0,8	400 // 0,8	400 // 0,8	400 // 0,8	400 // 0,8	
	Dimensiones largo x ancho x alto [mm]	918/843/925	918/843/925	918/843/925	1110/843/1322	1110/843/1322	1110/843/1322	
	Dim embalaje largo x ancho x alto [mm]	920/850/1010	920/850/1010	920/850/1010	1150/900/1400	1150/900/1400	1150/900/1400	
	Potencia acústica LWA [dBA]	NO	NO	NO	NO	NO	NO	
	Presión acústica LPA [dBA] 16m/10m/7m/4m	NO	NO	NO	NO	NO	NO	
	Depósito [l] / Autonomía 75% [h]	NO	NO	NO	NO	NO	NO	
	Unidades por container 20' / 40'	12 / 28	12 / 28	12 / 28	10 / 20	10 / 20	10 / 20	
Gearbox	Model	A-624	A-624	A-624	A-624	A-624	A-624	Gearbox
	Manufacturer	COMER	COMER	COMER	COMER	COMER	COMER	
	RPM	435	435	435	435	435	435	
	Relation / Rate	1 : 3,28	1 : 3,28	1 : 3,28	1 : 3,28	1 : 3,28	1 : 3,28	
ALT	Code	13965	13825	13969	17697	17660	17699	ALT
	Model	TW132 MA/4	TW132 LA/4	TW132 LB/4	TBM200 SA/4	TBM200 MA/4	TBM200 MB/4	
	Manufacturer	SACCARDO	SACCARDO	SACCARDO	SACCARDO	SACCARDO	SACCARDO	
	Regulation	COMPOUND	COMPOUND	COMPOUND	AVR	AVR	AVR	
	IP index protection	IP23	IP23	IP23	IP23	IP23	IP23	
CEE	CEE	G5 SACO T20 C	G5 SACO T25 C	G5 SACO T30 C	G5 SACO T42 C	G5 SACO T62 C	G5 SACO T72 C	CEE
	Pricing	Tractor driven generator code	13965	13825	13969	17697	17660	17699
Retail price	2.050 €	2.238 €	2.399 €	4.260 €	4.898 €	5.120 €		
Net & Gross weight [kg]	186 / 190	204 / 210	216 / 220	385 / 400	430 / 445	470 / 490		
Panel	Panel type	CEE-NSM	CEE-NSM	CEE-NSM	CEE-NSM	CEE-NSM	CEE-NSM	Panel
	CPU controller	NO	NO	NO	NO	NO	NO	
	Voltmeter	YES	YES	YES	YES	YES	YES	
	Frequencymeter	YES	YES	YES	YES	YES	YES	
	Circuit breaker thermomagnetic	YES	YES	YES	YES	YES	YES	
	Differential	YES	YES	YES	YES	YES	YES	
	Shockets	YES	YES	YES	YES	YES	YES	



ABAMOTOR ENERGÍA, S.L.

Astola, 6-C - 48220 Abadiano (Vizcaya)

España / Spain / Espagne

Telfs: 34 - 94 620 27 17 ---- 34 94 620 27 41

Fax: 34 - 94 620 33 34

E-mail: abamotor@sarenet.es ***** <http://www.abamotor.com>